



Mass Flow Controller (MFC)/ Mass Flow Meter (MFM) for Gases

- Direct flow measurement for nominal flow rates from 10 ml_N/min to 80 l_N/min (N₂) in MEMS technology
- High accuracy and repeatability
- Very fast response time
- Communication via fieldbus based on CANopen

Type 8741 can be combined with...



Type ME2X

System Control Unit with
Gateway functionality



Type 8741 can be configured either as MFC or MFM and is intended for the use in a bÜS or CANopen network. The bÜS network technology which is based on CAN physics was developed by Bürkert especially for applications with quite a number of control loops run by Industrial Ethernet or other fieldbuses. The System Control Unit (SCU) Type ME2X (please see datasheet) transfers a customer's PLC fieldbus into the proprietary bÜS communication and operates all electronic devices connected.

The communication of the devices can be switched from bÜS to CANopen. Given that, Type 8741 can also be integrated into an existing CANopen infrastructure.

Type 8741 measures (MFM) or controls (MFC) the mass flow of gases using a MEMS sensor. The sensor is in direct contact with the gas and therefore reaches very fast response times of a few hundred milliseconds. Furthermore, the measurement is independent from pressure or temperature deviations. The MFC/MFM can optionally be calibrated for two different gases, the user is able to switch between them.

Technical data	
Materials	
Body	Aluminium or stainless steel
Housing	PC (Polycarbonate)
Seals	FKM or EPDM (dep. on gas)
Port connection	NPT 1/4, G 1/4, screw-in fitting or sub-base, others on request
Control valve (direct-acting, seat, solenoid with MFC only)	Normally closed
Valve orifice range	0.05 to 4 mm
k _v s value range	0.00006 to 0.32 m ³ /h
Electrical connection	Terminal block 4-pin
Power Supply	24V DC
Voltage tolerance	± 10%
Power consumption	Max. 1W (as MFM), Max. 3 to 10 W (as MFC, depending on type of solenoid control valve)
Residual ripple	± 2%
Digital communication	CANopen or CAN-based bÜS
Removable memory	EEPROM (SIM card: bÜS relevant data and informations about spec. control loop in order to ease replacement)

Technical data	
Input-/ Output signals	none, communication via bus
Protection class	IP20
Dimensions	See drawings on pages 4 to 6
Total weight	ca. 500 g (aluminium body)
Installation	Horizontal or vertical
Device status	RGB-LED based on NAMUR NE107
Nominal flow range (Q_{nom})	10ml _N /min to 80 l _N /min (N ₂)
Turn-down ratio	50:1, optional 100:1
Operating media	Neutral gases (others on request)
Calibration gas	Operating gas or air
Max. operating pressure	10 bar (145 psi), with MFCs the max. pressure depends on the orifice of the valve
Gas temperature	-10 to +70 °C (-10 to +60 °C with oxygen)
Ambient temperature	-10 to +50 °C
Accuracy	±0.8% o.R. ±0.3% F.S. (after 1 min. warm up time)
Repeatability	±0,1% F.S.
Settling (MFC)/ response (MFM) time t_{95%}	< 300 ms

Nom. flow ranges of typical Gase²⁾

Nom. flow ranges of typ. Gases ¹⁾		
Gas	Min. Q_{Nom} [l _N /min]	Max. Q_{Nom} [l _N /min]
Argon	0.01	80
Helium	0.01	500
Carbon dioxide	0.02	40
Air	0.01	80
Methane	0.01	80
Oxygen	0.01	80
Nitrogen	0.01	80
Hydrogen	0.01	500
Propane	0.03	22

¹⁾ All values refer to 1.013 bara and 0°C (Index N)

Pressure Loss Diagram of a MFM (ref. to air, with 250µm inlet filter)

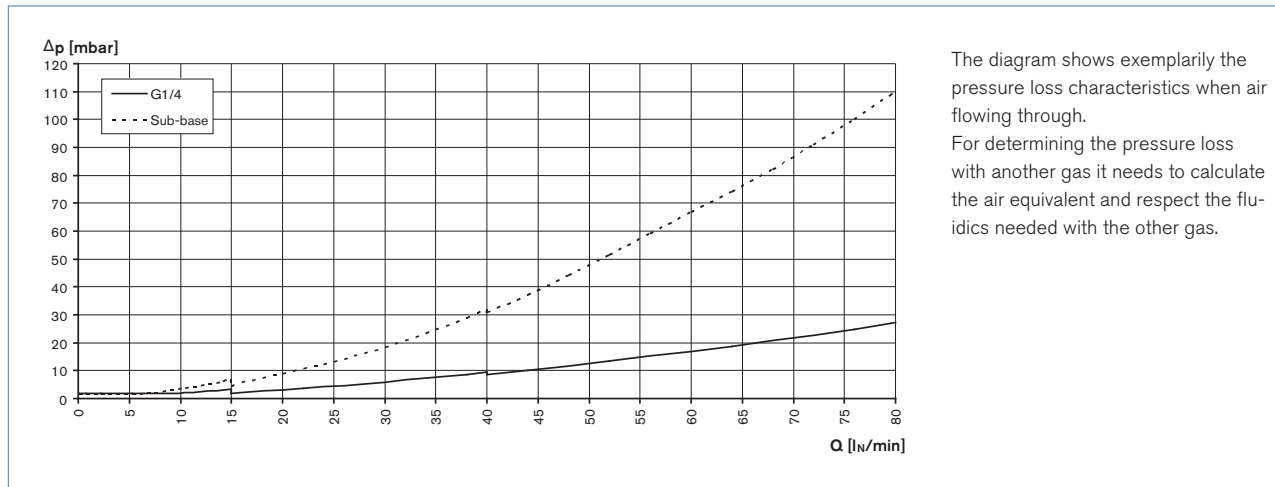

The diagram shows exemplarily the pressure loss characteristics when air flowing through.

For determining the pressure loss with another gas it needs to calculate the air equivalent and respect the fluidics needed with the other gas.

Notes Regarding the Configuration

For the proper choice of the actuator orifice within the MFC, not only the required maximum flow rate Q_{nom} , but also the pressure values *directly* before and after the MFC (p_1 , p_2) at this flow rate Q_{nom} should be known. In general, these pressures are not the same as the overall inlet and outlet pressures of the whole plant, because usually there are additional flow resistors (tubing, additional shut-off valves, nozzles etc.) present both before and after the controller.

Please use the request for quotation form on p. 8 to indicate the pressures *directly* before and after the MFC. If these should be unknown or not accessible to a measurement, estimates are to be made by taking into account the approximate pressure drops over the flow resistors before and after the MFC, respectively, at a flow rate of Q_{nom} . In addition, please quote the maximum inlet pressure p_{1max} to be encountered. This data is needed to make sure the actuator is able to provide a close-tight function within all the specified modes of operation.

▶ The request form on page 8 contains the relevant fluid specification. Using the experience of Bürkert engineers already in the design phase provide us with a copy of the request containing the necessary data together with your inquiry or order.

Measuring Principle

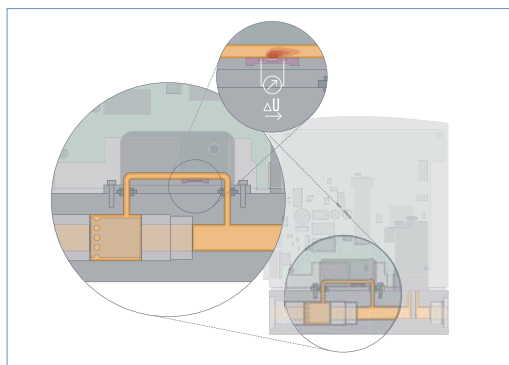

The actual flow rate is detected by a sensor. This operates according to a thermal principle which has the advantage of providing the mass flow which is independent on pressure and temperature.

A small part of the total gas stream is diverted into a small, specifically designed bypassing channel which ensures laminar flow conditions. The sensor element is a chip immersed into the wall of this flow channel. The chip, produced in MEMS technology, contains a heating resistor and two temperature sensors (thermopiles) which are arranged symmetrically upstream and downstream of the heater. The differential voltage of the thermopiles is a measure of the mass flow rate passing the flow sensor. The calibration procedure effectuates a unique assignment of the sensor signal to the total flow rate through the device.

Pin Assignment

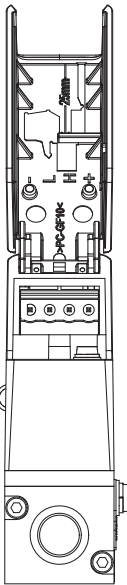

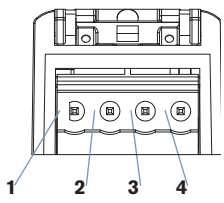
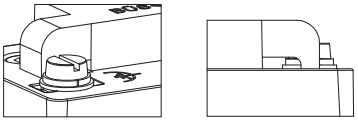
Terminal block 4-pin	Pin	Assignment
	1	GND
	2	CANL
	3	CANH
	4	24
Screw M3	Assignment	
	Functional earth	

Software Bürkert Communicator



The screenshot shows the Bürkert Communicator software interface. The main display area shows the following data:

- Medium: (LUF)
- Istwert: 0.00 NI/min
- aktueller Sollwert: 0.00 NI/min
- Mediumtemperatur: 26.7°C

The interface also includes a navigation menu on the left with options like Desktop, Graph, and BÜS on COM27. The top menu bar includes Projekt, Bearbeiten, Ansicht, Optionen, Hilfe, and Debug. The bottom status bar shows Zoom at 115%.

Part of Bürkert's new EDIP program (Efficient Device Integration Platform) is the Bürkert Communicator. This software can be run under MS-Windows and allows users to program further parameters in MFCs or watch process controls. It is freely available on Bürkert's website. An accessory part, the büS stick – please see ordering chart for accessories, serves as the interface between computer and process instrument I want to connect to. It transfers "USB data" to "CAN data". The Communicator allows:

- Diagnosis
- Parameterization
- Registration and storage of process data
- Data logging
- To watch graph of process
- To update firmware of the büS device connected
- To program system controls by User-f(x) – e.g. gas blending
- ...

Dimensions [mm]

Standard version

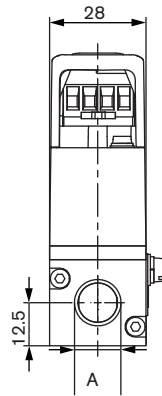
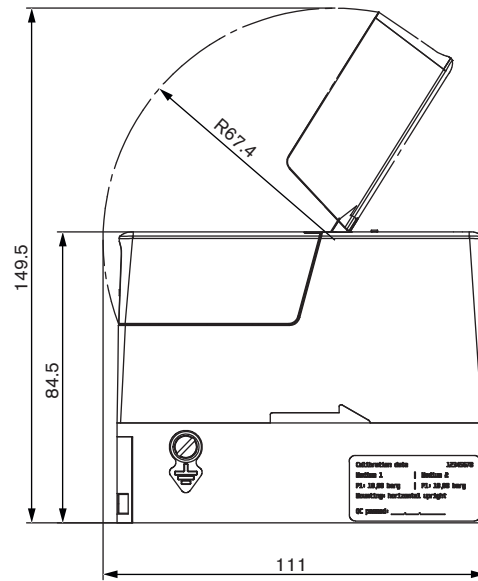
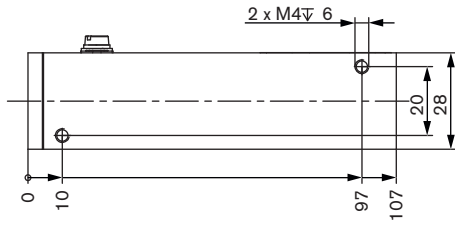

A: G1/4 or NPT1/4, depth 12mm

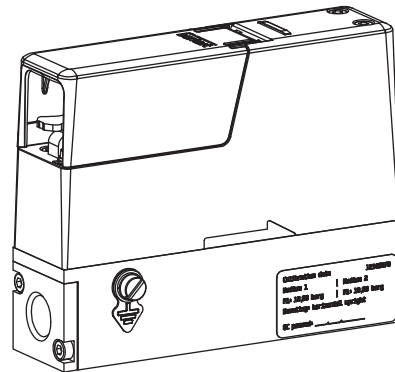
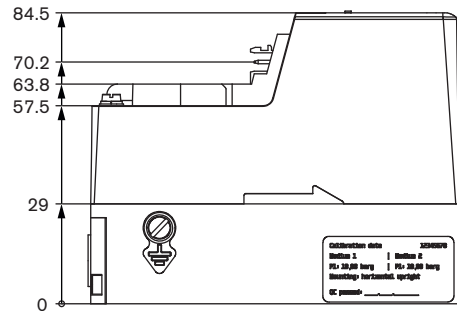

Dimensions [mm]

Subbase version

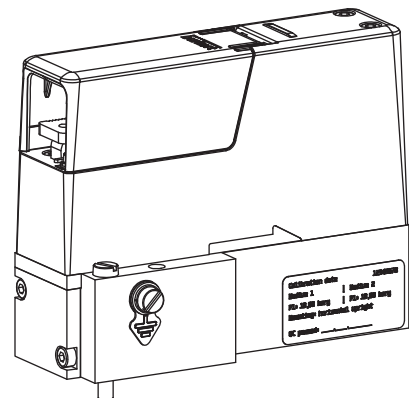
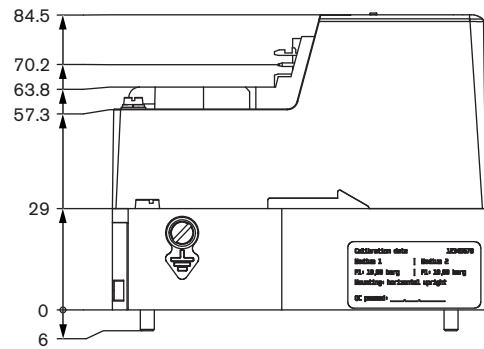
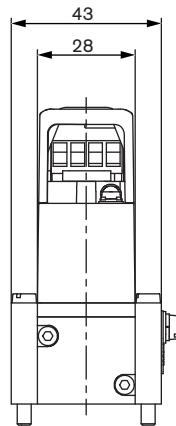
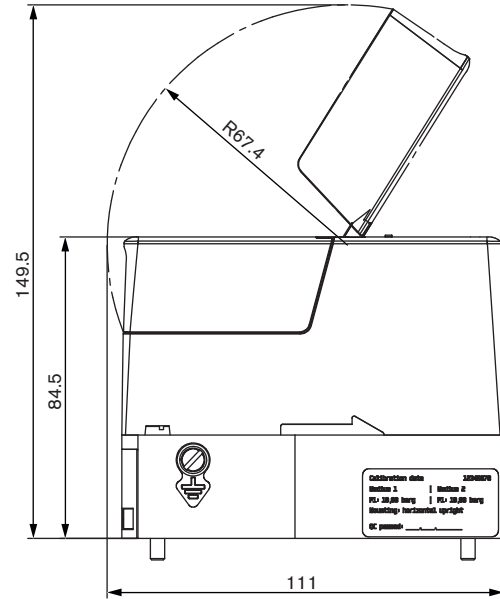
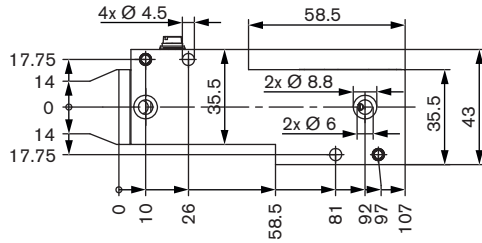

Dimensions [mm]

Version with external valve

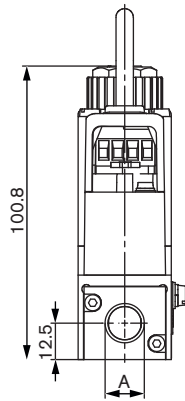
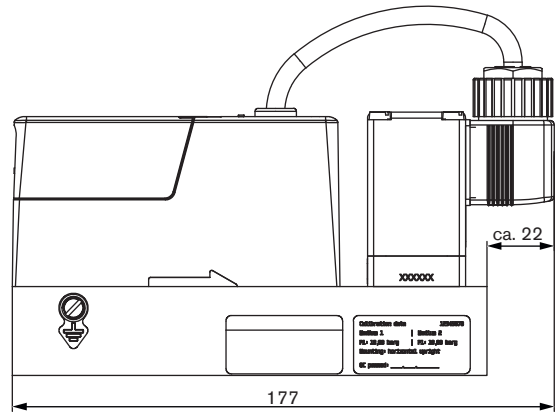
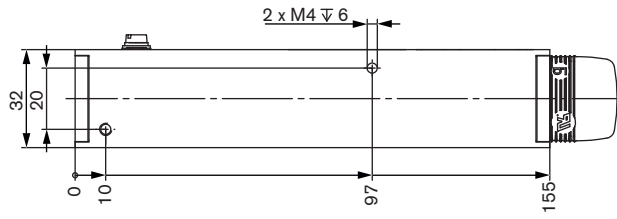

A: G1/4 or NPT1/4, depth 12mm

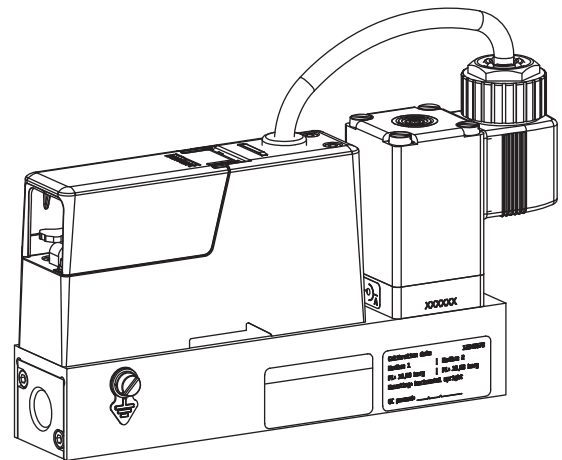
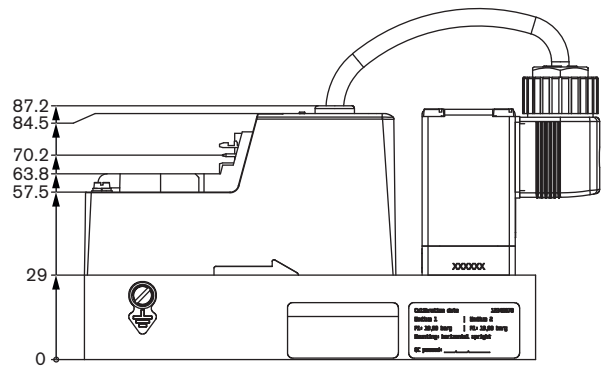

Ordering chart for accessories

Article	Item No.
Terminal block 4-pin (see drawing below)	565 876
Terminal block 4-pin with integrated 120 Ohm resistor for bus termination	566 066
büS-Stick Set 1 (incl. cable (M12))	772 551
büS-Stick Set 2 (incl. cable (M12), büS termination, power supply, and software)	772 426
SIM card	On request
EDS-File (büS, CANopen)	Download from www.burkert.com
Software Bürkert Communicator	Download from www.burkert.com

Terminal block 4-pin

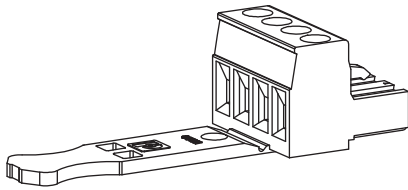

büS-Stick

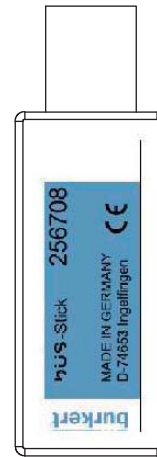
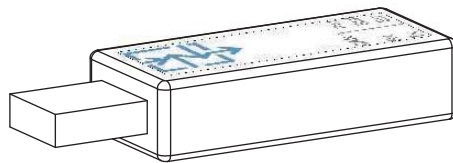
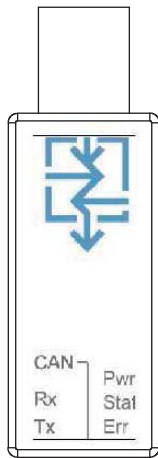

MFC/MFM-applications - Request for quotation

▶ Please complete and send to your nearest Bürkert sales centre

Company	Contact person
Customer No	Department
Address	Tel./Fax
Postcode/Town	E-mail

 MFC-Application MFM-Application Quantity Required delivery date

Medium data

Type of gas (or gas proportion in mixtures)

Density kg/m³ ⁸⁾

Gas temperature [°C or °F] °C °F

Moisture content g/m³

Abrasive components/solid particles no yes, as follows:

Fluidic data

Flow range Q_{nom} Min. l_N/min ⁸⁾ l_S/min (slpm) ⁹⁾
 Max. m_N³/h ⁸⁾ kg/h
 cm_N³/min ⁸⁾ cm_S³/min (sccm) ⁹⁾
 l_N/h ⁸⁾ l_S/h ⁹⁾

Inlet pressure at Q_{nom} ¹⁰⁾ $p_1 =$ bar(g) ■

Outlet pressure at Q_{nom} $p_2 =$ bar(g) ■

Max. inlet pressure P_{1max} bar(g) ■

MFC/MFM port connection without screw-in fitting
 1/4" G-thread (DIN ISO 228/1)
 1/4" NPT-thread (ANSI B1.2)
 with screw-in fitting (acc. to specification for pipeline)
 mm Pipeline (external Ø)
 inch Pipeline (external Ø)
 Flange version

Installation horizontal
 vertical, flow upwards vertical, flow downwards

Ambient temperature °C

Material data

Body base Aluminium Stainless steel

Seal FKM EPDM

Electrical data

Signals for set point and actual value CANopen or büS

■ Please quote all pressure values as overpressures with respect to atmospheric pressure bar(ü)

⁸⁾ at: 1,013 bar(a) and 0 °C

⁹⁾ at: 1.013 bar (a) and 20 °C

¹⁰⁾ matches with calibration pressure

To find your nearest Bürkert facility, click on the orange box →

www.burkert.com