

## LH-LED 100

This LED cold-light source for medical and industrial applications is strictly adapted for Köhler's illumination input of classical as well as modern microscopes. Due to the neutral white light and high illumination intensity, it is a modern alternative in many applications to conventional lamp housings designed for halogen lamps. Due to the very good homogeneity of the light field, there is no need for diffusing screens in the light path of the microscope. The light output can be adjusted via an easily accessible button on the side of the lamp housing, a remote control panel or via standard interfaces (like USB, CAN bus) for easy integration into computer-controlled systems. In contrast to halogen light sources, the colour temperature does not change when dimming.

The high service life and efficiency of the LED and the control electronics integrated in the lamp housing, as well as the fanless temperature management, guarantee operating cost savings of up to 80%.

The completely electronic shutter or alternatively flash function with a maximum of 26 kHz opens up new possible uses in fluorescence microscopy.



Lighting

HBO/XBO

## Spectrum LH-LED 100 compared to 100 W halogen

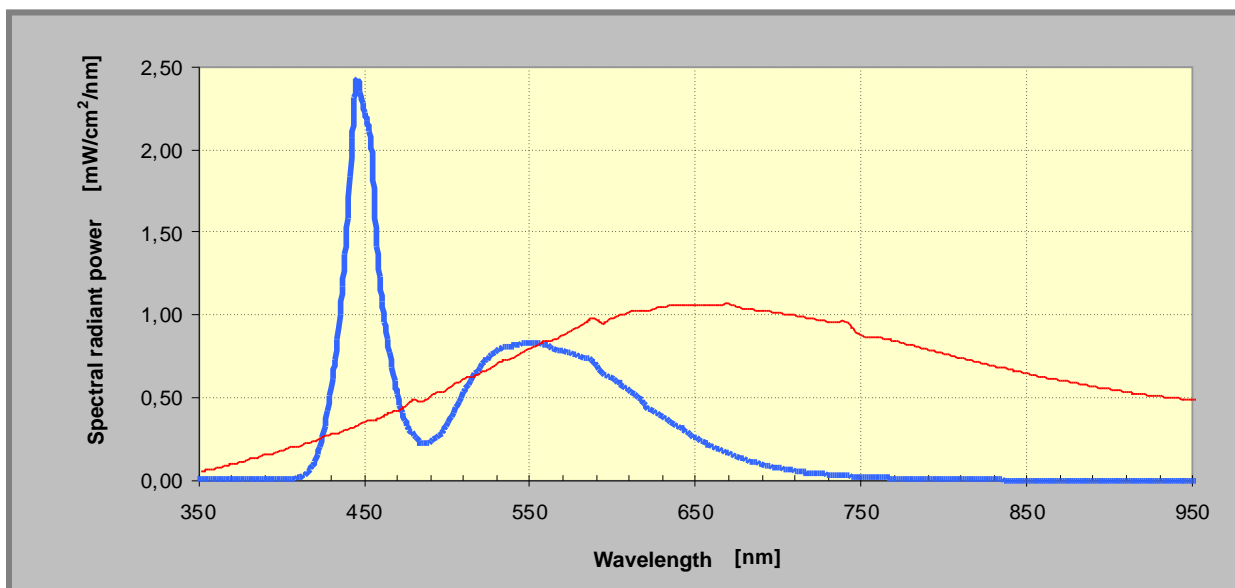

Light sources

Flashlights

UV-Equipment

Other

## Features

- light output greater than 750 lm, colour temperature is typically 6500 KI
- up to 80% lower operating costs than comparable cold-light sources
- maintenance-free operation for more than 50,000 h
- fanless, no vibrations
- low load from thermal radiation on object to be illuminated
- 0.2% up to 30% PWM, 30% up to 100% analog dimmable
- external trigger up to 26 kHz
- CE, RoHS and NRTL compliant

## Equipment

- trigger input
- synchronous output
- changeable microscope adapter
- interfaces for:
  - remote controller
  - optional USB- or CAN-bus-interface
  - optional analogue control voltage
- external wide range power supply

Subject to alterations with regard to technological progress

## Technical data LH-LED 100 / device equipment

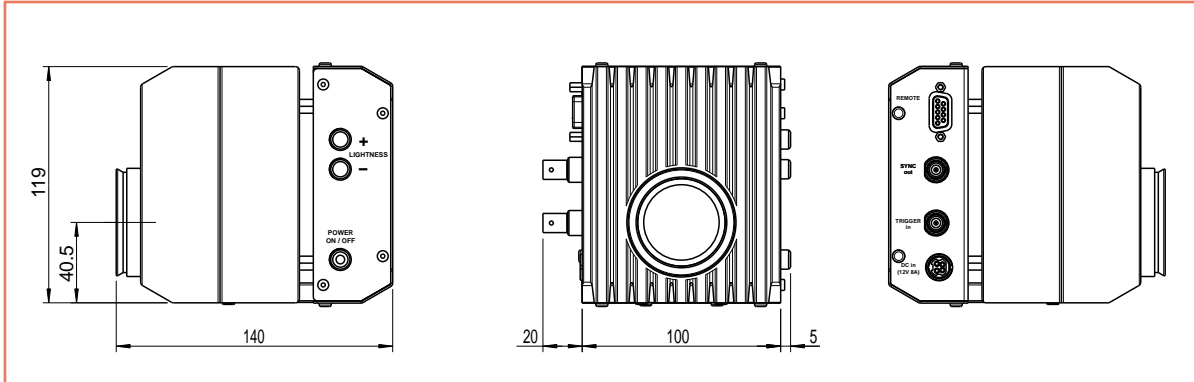

### Lighting

#### Electrical connection

Mains voltage 12 VDC  $\pm$  5 %, external power supply 100 up to 240 VAC, 50 up to 60 Hz

### HBO/XBO

Power input max. 50 VA

Protection class IP 20 (EN 60529)

### Light sources

#### Dimensions

H x W x D 120 x 125 x 140 mm

Weight ca. 2 kg

### Flashlights

#### Equipment

Trigger (Shutter) max. frequency 26 kHz, switching time approx. 40  $\mu$ s  
control via TTL switching input

### UV-Equipment

Sync-Out TTL switching output max. 26 kHz

### Other

Dimming electronic, 100 steps 0,2 ... 100%

Safety over-temperature protection

#### Configurations

-Z, -L, -N, -O microscope adapter Zeiss, Leica, Nikon, Olympus

## Accessories LH-LED 100

- control desks (remote controller)
- USB-, RS232-Adapter
- microscope adapter
  - Zeiss
  - Leica
  - Nikon
  - Olympus
  - others on request
- wide range power supply mains cable included

Order	
Scope of delivery	device with wide range power supply, mains cable, microscope adapter and manual
Order example	LH-LED 100-Z
customer-specific configuration options, please do not hesitate to contact us.	