

Type **TVR2**

Stainless Steel Check Valve



General

DESCRIPTION



Features

- Stainless steel 1.4305 (AISI 303)
- Extremely leak tight
- Seals are protected from the media flow
- Wear and corrosion resistant
- Low-noise opening and closing
- Low cracking pressure – starting from 0.01 bar
- Max. operating pressure – up to 1000 bar

High performance check valves for use with liquid and gaseous media

The seals are protected from the media flow thus minimizing the effect of dirt particles on the sealing components within the unit. The WEH-Check valves are constructed from high-grade materials achieving a very durable unit. The check valves are silent in use even under high flow requirements and offer minimum opening pressures from 0.01 bar onwards with high sealing integrity. The high performance sealing system ensures that the TVR2 is suitable for applications with gaseous media. WEH not only offer check valves with threaded connections but also with ferrule fittings, flanges, hose nozzles, nipples or custom designed cartridge valves, even for small quantities.

Application

TVR2 check valves are for use with liquid and gaseous media.

The WEH Check Valves can be used for a large range of applications in mechanical engineering and construction, chemical / pharmaceutical and food industry, materials-handling and medical technology etc.

OVERVIEW TYPES

WEH offer various types of TVR2 check valves:



TVR2 | Stainless steel check valves with double ferrule fitting on both sides



TVR2 | Stainless steel check valves with internal thread and external thread



TVR2 | Stainless steel check valves with internal thread on both sides



TVR2 | Stainless steel check valves with double ferrule fitting and internal thread



TVR2 | Stainless steel check valves with external thread on both sides



TVR2 | Stainless steel check valves with double ferrule fitting and external thread

General

TECHNICAL DATA

Characteristic	Basic version	Options
Port A / B	Double ferrule fitting: tube Ø 6 - tube Ø 16 mm Internal thread: G1/8" - G2" External thread: G1/8" - G1"	Double ferrule fitting: up to max. tube Ø 50 mm on request Internal thread: up to max. G3" on request External thread: up to max. G3" on request
Nominal bore DN	Acc. to design	On request
Operating pressure PB	Double ferrule fitting: max. 350 bar Internal thread: max. 400 bar (up to G3/4") max. 250 bar (from G1" onwards) External thread: max. 400 bar	Higher pressures on request.
Cracking pressure PC	Approx. 0.1 bar / 0.5 bar / 1.0 bar, acc. to design.	Approx. 0.01 bar / 0.1 bar / 0.2 / 0.5 / 1.0 bar Other cracking pressures on request.
Temperature range	-20 °C up to max. +120 °C	Depending on version and application temperature from -45 °C up to max. +300 °C. Other temperature ranges on request.
Medium	Liquid or gaseous	On request
Material	Stainless steel 1.4305 (AISI 303). Up to DN 8 mm, some inner parts brass.	Stainless steel 1.4571 (AISI 316Ti) Other materials on request.
Spring material	Stainless steel 1.4310 (AISI 301)	Stainless steel 1.4571 (AISI 316Ti) Other materials on request.
Sealing material	FKM	FFKM, EPDM, Silicone, Urethane, PTFE, PEEK, NBR Other sealing materials on request.
Valve seat	Up to DN 6 mm ball sealing, larger dimensions cone sealing.	On request
Approval	PED 97/23/EC For automotive applications other approvals are available. Please contact us!	

Flow values

Please find in the table below flow rates for various nominal bores of the TVR2 stainless steel check valves.

Nominal bore DN	Cv-Value	Nominal bore DN	Cv-Value
5 mm	0.4	20 mm	10.6
6 mm	0.5	25 mm	14.7
10 mm	2.9	32 mm	27.7
14 mm	7.4	40 mm	38.1
16 mm	8.1	50 mm	57.4

The flow curves were determined on the basis of the standards EN 60534 with water and refer to a cavitation free flow. The curves relate to unrestricted inlet and outlet.

Sealing types

Up to DN 6 mm ball sealing, larger dimensions cone sealing.

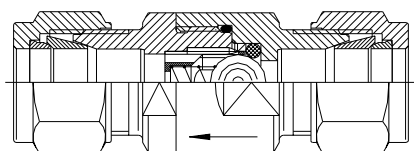

Ball seal construction

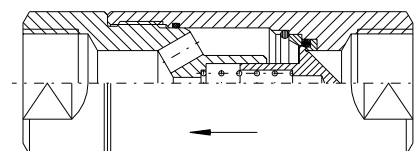

Cone seal construction

Ordering

ORDERING | TVR2 with double ferrule fitting on both sides

approx. dimensions (mm)

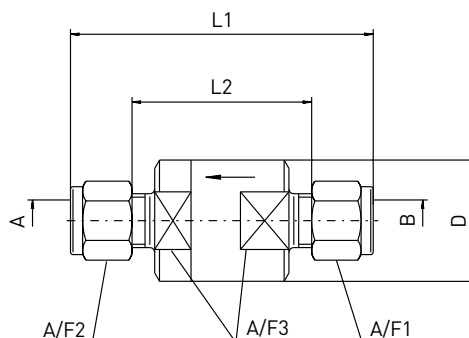

Type ball sealing



Part No.	DN	A / B	PB (bar)	PC (bar)	D	L1	L2	A/F1 A/F2	A/F3
C20010	5	Tube Ø 6	350	0.1	25	64	33.7	14	22
C20011	6	Tube Ø 8	350	0.1	25	64	33.7	16	22
C20012	6	Tube Ø 10	350	0.1	25	64	33.7	19	22
C20013	6	Tube Ø 12	350	0.1	25	70	33.7	22	22

Type cone sealing



Part No.	DN	A / B	PB (bar)	PC (bar)	D	L1	L2	A/F1 A/F2	A/F3
C20014	10	Tube Ø 12	350	0.5	35	110	62.7	22	30
C20015	14	Tube Ø 16	350	0.5	35	112	62.7	25	30

Ordering

ORDERING | TVR2 with internal thread on both sides (DIN ISO 228-1)

approx. dimensions (mm)

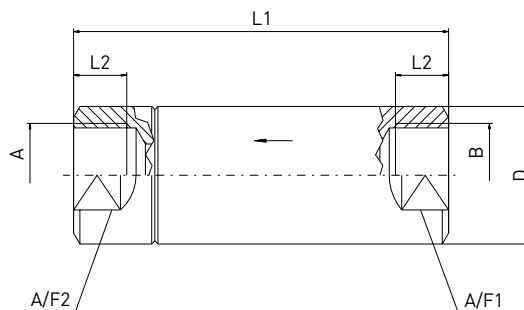

Type ball sealing



Part No.	DN	A / B	PB (bar)	PC (bar)	D	L1	L2	A/F1 A/F2
C20000	6	G1/8" internal thread	400	0.1	25	52	10	22
C20001	6	G1/4" internal thread	400	0.1	25	52	10	22

Type cone sealing



Part No.	DN	A / B	PB (bar)	PC (bar)	D	L1	L2	A/F1 A/F2
C20002	14	G3/8" internal thread	400	0.1	35	95	17	30
C20003	14	G1/2" internal thread	400	0.5	35	95	17	30
C20004	16	G3/4" internal thread	400	0.5	39	110	17	34
C20005	20	G1" internal thread	250	1.0	48	120	18	41
C20006	25	G1 1/4" internal thread	250	1.0	60	125	22	50
C20007	32	G1 1/2" internal thread	250	1.0	65	130	22	55
C20008	40	G1 1/2" internal thread	250	1.0	69	145	22	60
C20009	50	G2" internal thread	250	1.0	88	152	24	75

Ordering

ORDERING | TVR2 with external thread on both sides (DIN ISO 228-1)

approx. dimensions (mm)

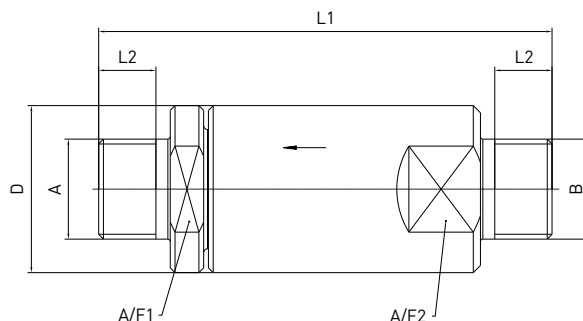

Type ball sealing

Part No.	DN	A / B	PB (bar)	PC (bar)	D	L1	L2	A/F1 A/F2
C20201	3	G1/8" external thread	400	0.1	25	52	10	22
C20202	5	G1/4" external thread	400	0.1	25	52	10	22



Type cone sealing

Part No.	DN	A / B	PB (bar)	PC (bar)	D	L1	L2	A/F1 A/F2
C20203	8	G3/8" external thread	400	0.1	35	95	12	30
C20204	12	G1/2" external thread	400	0.5	35	95	12	30
C20205	16	G3/4" external thread	400	0.5	39	110	12	34
C20206	20	G1" external thread	250	1.0	48	120	18	41

Ordering

ORDERING | TVR2 with external thread and internal thread (DIN ISO 228-1)

approx. dimensions (mm)



Part No.	DN	A	B	PB (bar)	PC (bar)	D	L	A/F1 A/F2
C1-95696	14	G1/2" internal thread	G1/2" external thread	400	0.1	35	95	30

ORDERING | TVR2 with double ferrule fitting and internal thread

approx. dimensions (mm)



Part No.	DN	A	B	PB (bar)	PC (bar)	D	L	A/F1 A/F2
C1-91624	6	UNEF 9/16"-24 internal thread	Tube Ø 10	350	1.0	25	73.5	22

ORDERING | TVR2 with double ferrule fitting and external thread

approx. dimensions (mm)



Part No.	DN	A	B	PB (bar)	PC (bar)	D	L	A/F1 A/F2
C1-81108	6	G1/4" external thread	Tube Ø 8	350	0.05	25	58.6	22

Other connector sizes are available on request.

Other products

OTHER PRODUCTS

Our check valve catalogue contains further steel or brass check valves.



Further information on our homepage
www.weh.com

Contacting

For queries and further information, please do not hesitate to contact our sales team at sales@weh.com.

WEH GmbH Precision Connectors
Siemensstr. 5
89257 Illertissen / Germany
Phone: +49 7303 9609-0
Fax: +49 7303 9609-9999
eMail: sales@weh.com
Internet: www.weh.com