

Modular differential pressure transmitter

MHDS



Müller Industrie-Elektronik GmbH
Justus-von-Liebig-Straße 24
31535 Neustadt / GERMANY

Tel.: (+49) 05032-9672-111
Fax: (+49) 05032-9672-199
info@mueller-ie.com
www.mueller-ie.com

MÜLLER

INDUSTRIE - ELEKTRONIK GMBH

Modular differential pressure transmitter MHDS with HART-protocol

In the heavy industry, the extreme requirements of the production processes formed the new product family of the robust Heavy Duty field instruments. Based on the long-time proven MK modular compact sensors, Müller Industrie-Elektronik has developed these devices for the use in particularly rough industrial environments, e.g. in chemistry, cement, steel and glass industry.

The Heavy Duty series was offer in extensive modular varieties: as temperature, pressure, differential pressure and level sensor. In development are flow and conductivity sensors. With different transmitter assembly (with HART protocol), with display and all current mostly required connections.

The HART-Tool is a graphical user interface for the MH series with menu-driven program for configuration. It can be used for putting into operation, configuration, analysis of signals, data backup, linearization of characteristic curve and documentation of the device. Operating systems: Windows2000, Windows XP

Connectivities to use HART-protocol are:

- interface (modem) with serial interface of a PC
- interface (modem) with USB interface of a PC
- Hand-held HART communicator

The pressure sensor MHDS is suitable to measure differential pressure. From this can be derived: flow rate (volumetric- and mass flow) and level (level, volume, mass). Typical areas of use are chemical industry and process engineering.

The resistant aluminum die cast housing corresponds to protection class IP65 according EN 60529. Release according ATEX ex and FM authorization for North America are in preparation.

Technical data (differential pressure sensor)

Input: 0...75 mbar bis 0...420 bar

Output: 4...20 mA HART protocol

Supply: 15...45 VDC (current loop)

Operation temperature: -20...70 °C

Process connection: 1/4" -18 NPT 1.4435 (316L)

Filter configuration

Short circuit protection

Display: 5 digits / bargraph / unit

Programming: 3 keys / HART interface

Range: -19999...99999

PC operational system: W2000 or higher

Technical dokumentation

Modular differential pressure transmitter

MHDS



Content:

Page 2: Characteristics - applications - technical data

Page 3: Input quantity - output quantity

Page 4: Electrical connection - process connection

Page 5: 4...20 mA test signal - external operator's control - turning of enclosure - wall- and tube mounting

Page 6: Electronics insert with display - HART communication

Page 7: Dimensions - definitions

Page 8: Ordering code

Characteristics

Input: differential pressure

Turn down: up to 100:1

Supply: current loop 15...45 VDC

Degree of protection: IP65

Configuration: with keys and/or software

Material enclosure: diecast aluminium

Process connection: 1/4-18 NTP

Measuring range: 75 mbar up to 420 bar

Output: 4...20 mA current loop, HART-protocol

Accuracy: 0,075%, 0,1, 0,2% of range (URL, LRL)

Indication: LCD-display with backlighting

Enclosure: rotating up to 360°

Pressurized parts: stainless steel 1.4435

Applications

The pressure sensor is suitable to measure differential pressure. From this can be derived: flow rate (volumetric- and mass flow) and level (level, volume, mass). Typical areas of use are chemical industry and process engineering.

Technical data

Eingang

Differential pressure:

75 mbar / 400 mbar / 2 bar / 7 bar /

21 bar / 70 bar / 200 bar / 420 bar

Static pressure: 30...420 bar

Output

Analog: 4...20 mA, 2-wire, with superimposed communication signal (HART-protocol)

Signal range: 3,6...22,8 mA

Failure: signal 3,6 mA

Accuracy

Type 75 mbar:

0,1% of FS up to turn down 5:1

$\pm(0,1+0,01 \cdot \text{URL/URV})$ for turn down

5:1 to 50:1

Types 400 mbar / 2 bar / 7 bar / 21 bar / 70 bar:

0,075% of FS up to turn down 10:1

$\pm(0,0751+0,00751 \cdot \text{URL/URV})$ for turn down

10:1 to 100:1

Types 200 bar / 420bar:

0,2% of FS up to turn down 10:1

$\pm(0,2+0,01 \cdot \text{URL/URV})$ for turn down 10:1 to 100:1

Influences:

static pressure: zero: $\pm 0,1\%/70$ bar
range: $\pm 0,2\%/70$ bar

supply: $< 0,005\%$ of nominal range/1V

vibration: $< 0,01\%$ of nominal range/g at 200 Hz

fitting position: zero drift, to compensate span drift: without

temperature: $< 0,45\%/55^\circ\text{C}$

Stability: $\pm 0,1\%$ of nominal range / 1 year

Rise-delay time: 5 s

Cycle time, update: 0,25 s

Damping: 200 ms (without consideration of electronic damping)

Filter adjustment: 0...160 μA

Display

Visible range: 32,5x22,5 mm

Indication: 5-digits 7-segments, 8 mm height

8-digits 14-segments, 5 mm height

bargraph with resolution 2%

Range: -19999...99999

Supply

Voltage: 15...45 VDC (current loop)

Insulation resistance: > 250 MOhm

Short circuit-proof: permanent

Reverse battery protection: yes (no destruction, no funtion)

Overvoltage protection: 500V

Environmental conditions

Operating temperature: $-20...70^\circ\text{C}$

Ambient temperature: $-20...70^\circ\text{C}$

Temperature medium: $-40...104^\circ\text{C}$

Storing temperature: $-40...+85^\circ\text{C}$

Humidity: 5...98% relative humidity

Mechanics

Material:

Enclosure electronics: diecast aluminium

Measuring membrane: stainless steel 1.4435
option: Hastelloy

Ventilating valve: stainless steel 1.4435

Joint pieces: stainless steel 1.4435

O-ring in contact with medium: Viton (FKM, FPM)

Flange screws: plain carbon steel, zinc coated

Type plate: stainless steel 1.4301

viewing glass: laminated glas

Process connection: 1/4-18 NPT

Dimensions: see page 7

Protection: degree IP 65

Weight: approx. 3,8 kg

Connection: terminal screw (maximum 1,5 mm²)
via srewed cable gland M20x1,5

Principle of measurement: capacitive

Standards: IEC 61000-4-3

Pressure equipment directive 97/23/EG

Input

Measurand: differential pressure
derived from thist: flow rate (volumetric- and mass flow)
level (level, volume, mass)

Measuring ranges: 75 mbar up to 420 bar

nominal range [mbar]	range limit lower (LRL) [mbar]	range limit upper (URL) [mbar]	working range smallest adjustable [mbar]	overload [bar]	
75	-75	+75	1,5	130	
400	-400	+400	4	130	
2000	-2000	+2000	20	130	
7000	-7000	+7000	70	130	
21000	-21000	+21000	210	130	
70000	-70000	+70000	700	125% of range	
200000	-200000	+200000	2000	125% of range	
420000	-420000	+420000	4200	115% of range	

Output

Output signal: 4...20 mA, 2-wire connection
with superimposed communication signal for HART protocol

Signal range: 3,6...22,8 mA

Load: $R_{Lmax} = (U - 15 \text{ V}) / 0,0228 \text{ A}$

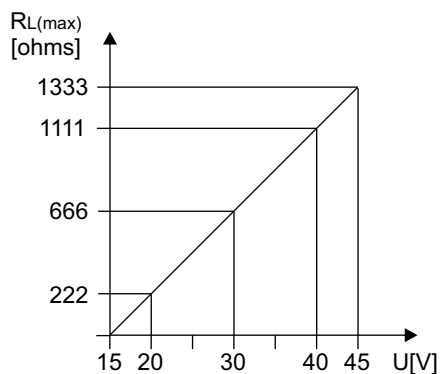

Voltage supply: 15...45 VDC

R_{Lmax} : maximum load resistance
U: Voltage supply

Please note: When using communication via a HART modem, a communication resistance of minimum 250 ohms has to be taken into account.

Resolution: current output: 16 bit
indication: adjustable (factory setting: 0...100%)

Read cycle time: HART commands all 200 ms.

Damping: continuously adjustable from 0 to 160 μA via electronic insert inside the device, hand-held equipment or PC-software. Factory configuration: 0 μA

Electrical connection

4...20 mA HART:

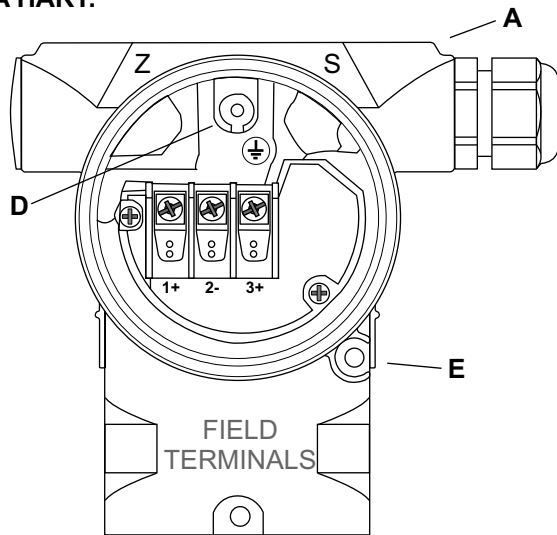

Electrical connection 4...20 mA HART

- A: Enclosure
- B: Voltage supply 15...45 VDC (1+ / 2-)
- C: 4...20 mA test signal between 2- and test point 3+
- D: Internal earthing
- E: External earthing

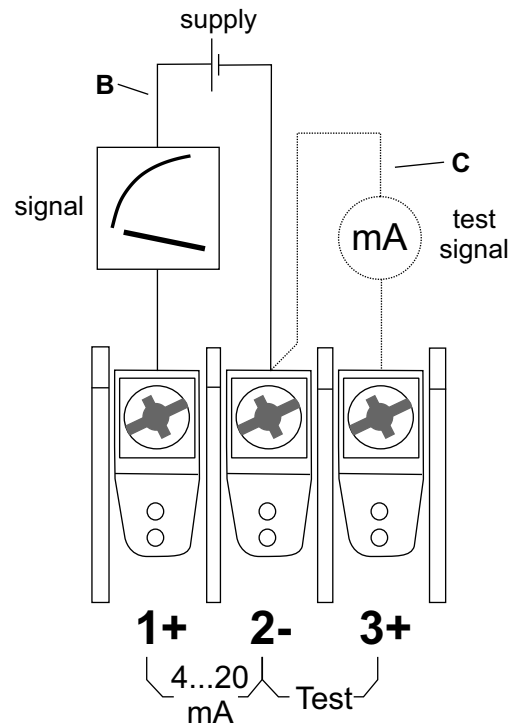

The device has a protective system against overvoltage peaks, RF interferences and wrong polarity.

Voltage supply: between 1545 VDC

Cable entry: screwed cable gland M20x1,5 (metal)

Cabel: outer diameter: 6...12 mm
cross-sectional area: 0,5...1,5 mm²
shielded and twisted 2-wire cable (recommended)

Residual ripple: no influence on mA-signal up to 5% within nominal voltage range

Influence supplied power: <0,005% of nominal range / 1V

Process connection

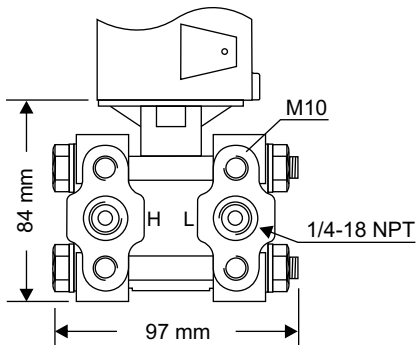

Pressure connection:
1/4-18 NPT AISI 316L (1.4435)

Measuring membrane:
stainless steel 1.4435

Mounting:
M10

Supplied accessories:
2 ventilating valves AISI 316L (1.4435)

4...20 mA test signal

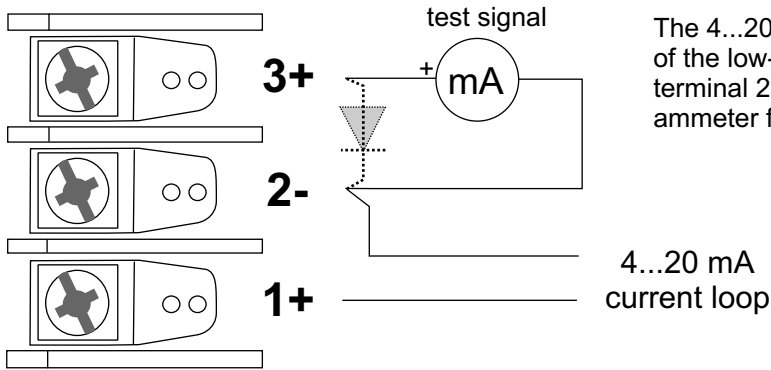

The 4...20 mA test can be measured without interruption of the low-potential circuit between terminal 3(+) and terminal 2(-). The output current is measured with an ammeter for mA across a diode in the output circuit.

External operator's control

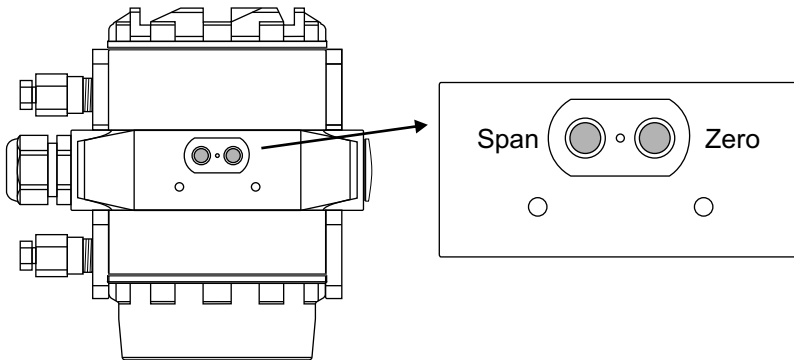

Below the type plate there are 2 key button for easy configuration of zero and span. The keys are Hall effect devices and are completely separated from other parts of the enclosure.

Advantages:

- Protection against environmental influence
- without wear
- ease of operation

Rotating of enclosure

After unscrewing the M6 Allen screw the enclosure can be rotated up to 360°.

Advantages:

- Good reading of the display
- Operator's controls of the device are easy approachable

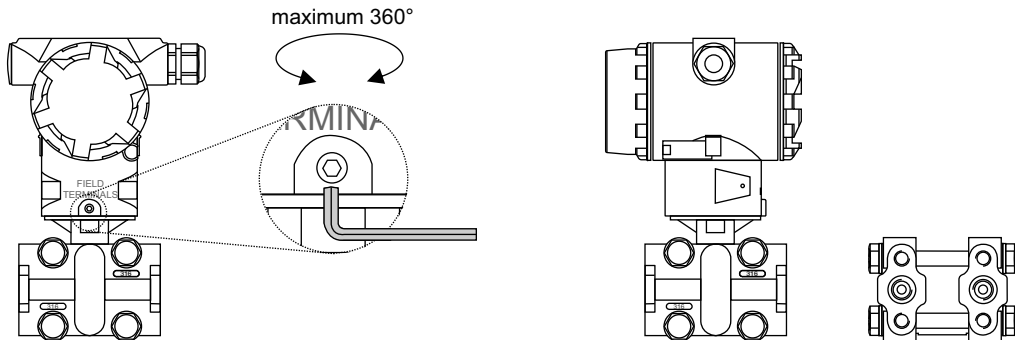

Wall- and tube mounting

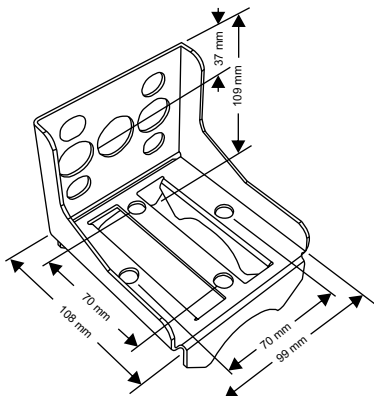

Holder made of steel (zinc coated) for mounting the device on walls or tubes is supplied with the device.

Supplied parts: holder, fixing clamp with nuts and washers.

The holder made of stainless steel can be selected as an option (additional price).

Electronic insert with display

Display with key buttons for configuration

The display is rotatable for approx. 330°

With 3 operator's keys is configurable:

- Starting measuring value (reference pressure has to be supplied)
- Final measuring value (reference pressure has to be supplied)
- Zero offset compensation (compensation of position)
- Reset
- Starting measuring value (reranging without reference pressure)
- Final measuring value (reranging without reference pressure)
- Damping
- Unit (mA, mbar, %)
- Fixed current output

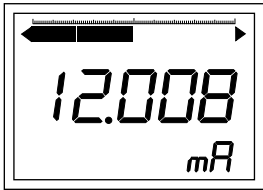
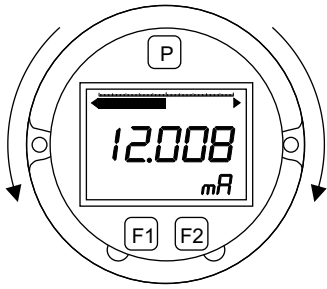

Display

- Visible range 32,5x22,5 mm
- 5-digits 7-segment line, 8 mm high (-19999...99999)
- 8-digits 14-segment line, 5 mm high
- Bargraph with resolution 2%

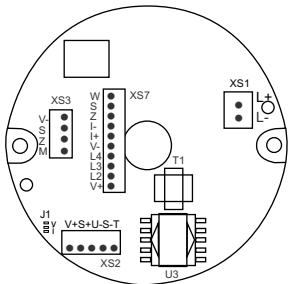

Electronics

- XS1 voltage supply 15...45 V
- XS2 connection sensor
- XS3 external keys
- XS7 display
- J1 solder bridge to select sensor supply

HART Communication

HART tool:

The HART-Tool is a graphical user interface for the MH series with menu-driven program for configuration. It can be used for putting into operation, configuration, analysis of signals, data backup and documentation of the device. Operating systems: Windows2000, Windows XP

Functions:

- Configuration of the devices in on-line operation
- Loading and storing the devices data (upload / download)
- Linearization of characteristic curve
- Documentation of the measuring point

Possible HART devices to use:

- HART interface (modem) with serial interface of a PC
- HART interface (modem) with USB interface of a PC
- Hand-held HART communicator

HART Communication

HART tool:

The HART-Tool is a graphical user interface for the MH series with menu-driven program for configuration. It can be used for putting into operation, configuration, analysis of signals, data backup and documentation of the device. Operating systems: Windows2000, Windows XP

Functions:

- Configuration of the devices in on-line operation
- Loading and storing the devices data (upload / download)
- Linearization of characteristic curve
- Documentation of the measuring point

Possible HART devices to use:

- HART interface (modem) with serial interface of a PC
- HART interface (modem) with USB interface of a PC
- Hand-held HART communicator

Dimensions

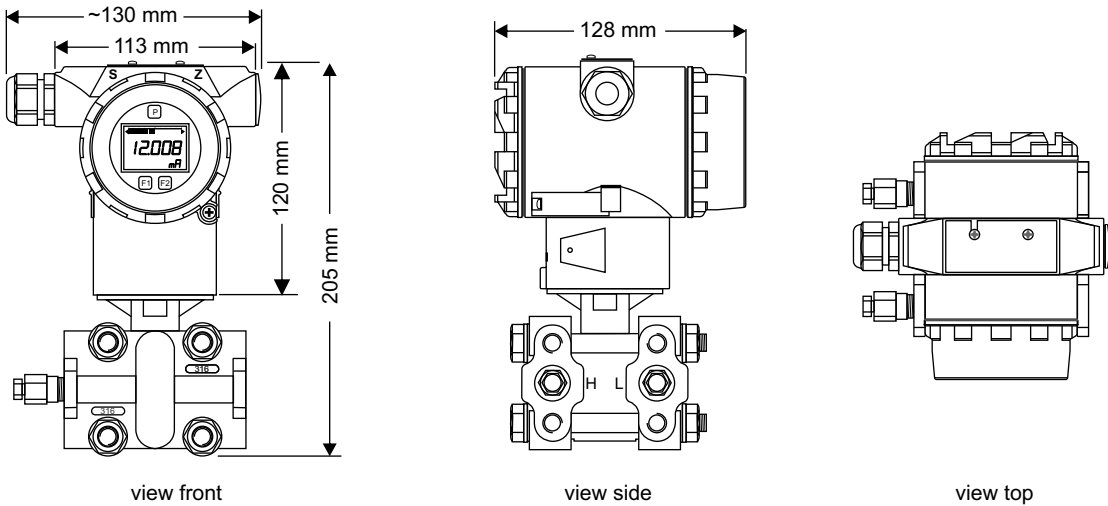

Definitions

LRL: lower range limit
 LRV: lower range value
 TD: turn down

URL: upper range limit
 URV: upper range value

Example 1

|LRV| < |URV|

lower range value (LRV) = 0 mbar
 upper range value (URV) = 200 mbar
 upper range limit (URL) = 400 mbar

Turn down:

$URL / |URV| = 400 \text{ mbar} / 200 \text{ mbar}$
 Turn down = 2 : 1

Set span:

$URV - LRV = 200 \text{ mbar} - 0 \text{ mbar}$
 set span = 200 mbar
 (The span is based on the zero point)

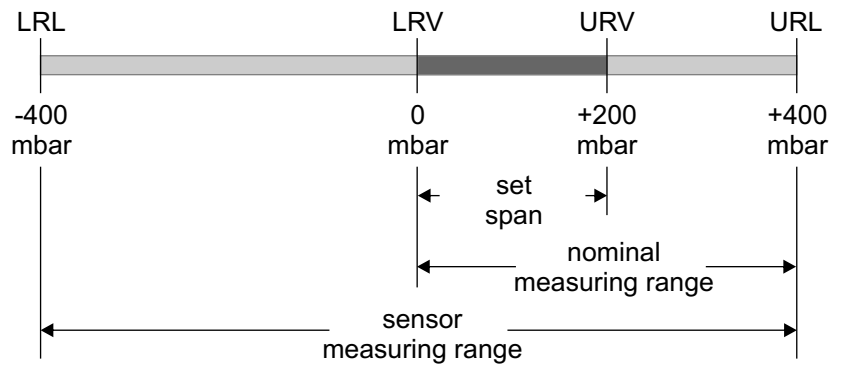

Example 2

|LRV| > |URV|

lower range value (LRV) = -300 mbar
 upper range value (URV) = 0 mbar
 upper range limit (URL) = 400 mbar

Turn down:

$URL / |LRV| = 400 \text{ mbar} / 300 \text{ mbar}$
 Turn down = 1,33 : 1

Set span

$URV - LRV = 0 \text{ mbar} - (-300 \text{ mbar})$
 set span = 300 mbar
 (The span is based on zero point)

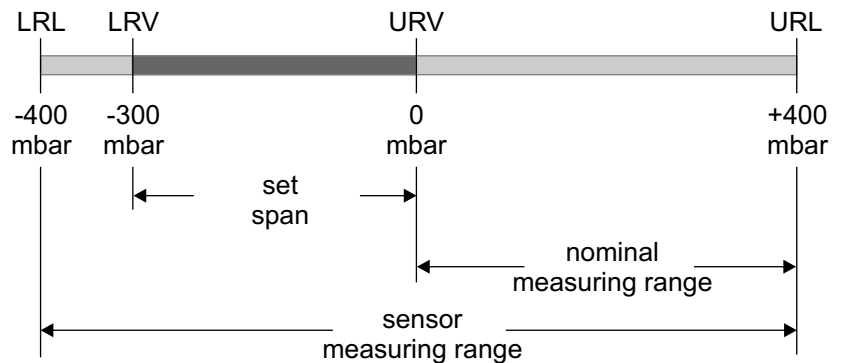

H D X X X X X X - X X X

Output:	4...20 mA (HART)	0									
Enclosure / electr. connection:	diecast aluminium / M20x1,5	0									
AP-range:	0...75 mbar (turn down 1:50)	0									
	0...400 mbar (turn down 1:100)	1									
	0...2 bar (turn down 1:100)	2									
	0...7 bar (turn down 1:100)	3									
	0...21 bar (turn down 1:100)	4									
	0...70 bar (turn down 1:100)	5									
	0...200 bar (turn down 1:100)	6									
	0...420 bar (turn down 1:100)	7									
Membrane:	stainless steel 1.4435	0									
	Hastelloy (on request)	1									
Process connection:	1/4-18 NPT 1.4435 (316L)	0									
Seal:	Viton (FKM)	0									
Configuration:	without (factory configuration)*	0									
	with (please indicate)**	1									
Options:	without	0									
	holder for wall/tube made of stainless steel (additional price)***	1									
Other / accessories:	special model	0									
	HART interface, USB, software	1									
	HART interface, RS232, software	2									

*zero: 4,000 mA / span: 20,000 mA / zero offset compensation: without / turn down: without / calibration points: 2 / damping: without / display mode: 100% / output on alarm: 3,6 mA / fixed output: without

**the possibilities of the technical data can be selected. In case of not given values the details of factory-set are used.

***as standard the differential pressure transmitter is supplied with a holder made steel (zinc coated). For an additional price a holder made of stainless steel can be selected

Price list
MHDS

interactive

valid as of 2007

HD differential pressure transducer

version 39-385

Subject to change

Cells for input in colour:

Deutsche Version wählen mit: d

Discount

Selection with: number no selection with: empty cell

		Price	Discount price	sum
1	0 Output			- €
	0 4...20 mA (HART)	- €	- €	
2	0 Enclosure / electrical connection			- €
	0 diecast aluminium / M20x1,5	- €	- €	
3	1 P-range			590,00 €
	0 0...75 mbar (turn down 1:50)	640,00 €		
	1 0...400 mbar (turn down 1:100)	590,00 €	590,00 €	
	2 0...2 bar (turn down 1:100)	590,00 €		
	3 0...7 bar (turn down 1:100)	590,00 €		
	4 0...21 bar (turn down 1:100)	590,00 €		
	5 0...70 bar (turn down 1:100)	590,00 €		
	6 0...200 bar (turn down 1:100)	590,00 €		
	7 0...420 bar (turn down 1:100)	590,00 €		
4	0 Membrane			- €
	0 stainless steel 1.4435	- €	- €	
	1 Hastelloy (on request)	- €		
5	0 Process connection			- €
	0 1/4-18 NPT 1.4435 (316L)	- €	- €	
6	0 Sealing			- €
	0 Viton (FKM)	- €	- €	
7	1 Settings			6,00 €
	0 without (factory settings)	- €		
	1 with (please give)	6,00 €	6,00 €	
8	1 Options			15,00 €
	0 without	- €		
	1 holder wall / tube stainless steel (instead of steel)	15,00 €	15,00 €	
9	2 Other / accessories			185,00 €
	0 special model	- €		
	1 HART interface, USB, software	195,00 €		
	2 HART interface, RS232, software	185,00 €	185,00 €	

MHDS

HD differential pressure transducer

	price
Output	- €
Enclosure / electrical connection	- €
P-range	590,00 €
Membrane	- €
Process connection	- €
Sealing	- €
Settings	6,00 €
Options	15,00 €
Other / accessories	185,00 €
HART interface, RS232, software	

Ordering code											
H	D	X	X	X	X	X	X	-	X	X	2

Gesamtsumme	796,00 €
--------------------	-----------------

Date: 01.08.2008

please specify

Factory-set: zero: 4,000 mA / span: 20,000 mA / zero offset compensation: without / turn down: without / calibration points: 2 / damping: without / indication: 0...100% / output on error / fixed: output: without

Configuration analogue to factory settings

Notes:

**Müller Industrie-Elektronik GmbH
Justus-von-Liebig-Straße 24
31535 Neustadt / GERMANY**

**Tel.: (+49) 05032-9672-111
Fax: (+49) 05032-9672-199
info@mueller-ie.com
www.mueller-ie.com**

MÜLLER

INDUSTRIE - ELEKTRONIK GMBH