

**KABELSCHLEPP**

the power to innovate

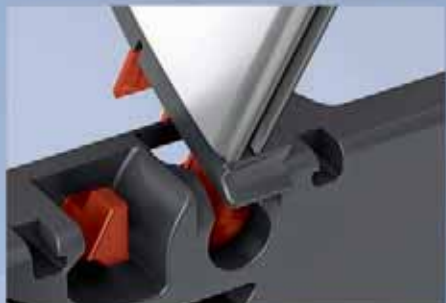
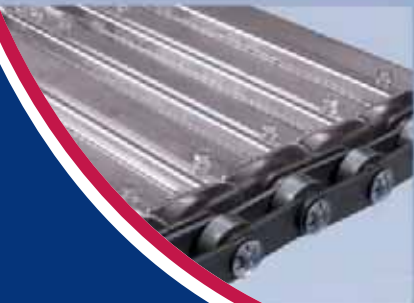

# Innovations 2008

Powerful products for powerful solutions.

The future requires innovations.

# KABELSCHLEPP 2008 – “The power to innovate”

Innovations are worthy of their name if they provide a truly new or significantly improved benefit to the customer. This year we have once again put together for you a range of innovations that truly deserve this designation.

Whether the new two-component cable carriers – extremely stable and flexible, but easy and quick to fill – or reliability on long travel lengths. For numerous application requirements we have developed innovations that will set trends in their fields. On top of that is our newly-developed “Web Service” for design engineers. This new configuration program will design the right cable carrier and much more for you, quickly and easily.

In the product area of guideway protection systems and conveyor systems, the main highlights include new materials with improved gliding characteristics for the wipers, or quieter telescopic covers and conveyors with new module connections.

All in all, a useful supplement and complement to our diverse product portfolio. And that applies for both technical and economic aspects. Only when both of these are incorporated in product developments is there true innovation. Discover our products, or let us demonstrate for you how we can improve your machine or system.

## The 2-shot-technology.

The 2-shot-technology of our new cable carriers makes it possible to unite seemingly non-integral characteristics: **Ruggedness and Flexibility.**

Cable carriers should be very rugged and have an extensive supporting length. At the same time they should afford quick and easy set-up.

The new cable carriers **EasyTrax** and **QuickTrax** unite these qualities through an innovative design and the materials combination of hard chain elements made of fiberglass reinforced material with lamella crossbars or film hinges made of specially formulated flexible synthetics/plastics.

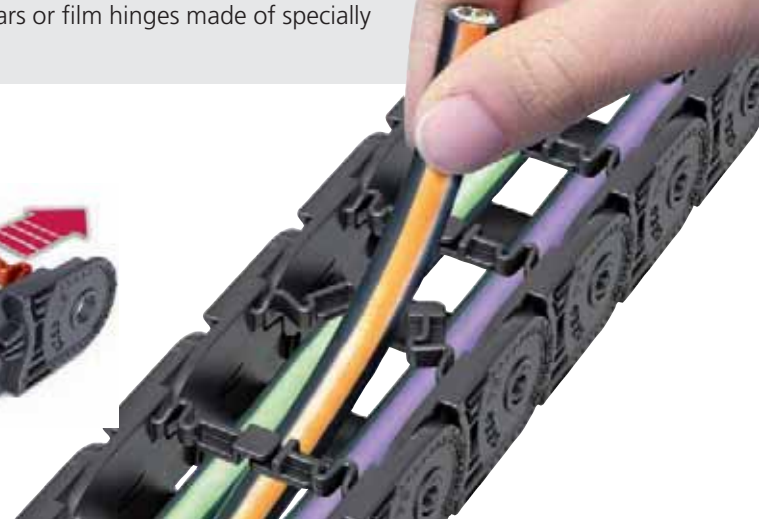

## CONTENTS Innovations 2008

	Page
<b>EasyTrax 0320.</b> Simply press in the cables – extremely stable design	4
<b>QuickTrax 0320.</b> Quick to open thanks to new film hinge	8
<b>UNIFLEX 1665.</b> Lighter, quieter, more effective	12
<b>LineFix saddle-type clamps.</b> Reliable cable fixing	16
<b>MC 1300 with ball joint.</b> Lightning-quick and easy to open	18
<b>MT 1300 with aluminum cover system.</b> Stable, robust, 1 mm sections	19
<b>MINI 0152.</b> Compact, stable, easy to fill	20
<b>UNIFLEX 1455 with external dampers.</b> Reducing rolling noise	21
<b>New divider systems for MC/MT 0950/1250.</b> New separation options	21
<b>MASTER LC 80 with new frame stays.</b> Easy-to-fit, robust, fixable dividers	22
<b>OnlineEngineer.</b> With just a few clicks of the mouse to an optimal KABELSCHLEPP cable carrier system	23
<b>LS/LSX 1050 with mounting frame stay.</b> Routing large cables reliably	24
<b>Glide shoes for S/SX 0950 as a standard injection-molded part.</b> Steel cable carrier in a gliding arrangement	25
<b>ECC – Emergency Cable Carrier.</b> Reliability for long travel lengths	26
<b>New LIFE-LINE cable types.</b> Power ONE 700 PE. Continuous bending highly-flexible PUR single-core cables	28
USB 700 CD. Continuous bending highly-flexible USB PUR cable	28
System cables. Continuous bending highly-flexible PUR signal cables	29
System cables. Continuous bending highly-flexible PUR power cable	29
DATA 200 C. Continuous bending highly-flexible PVC data cable	30
DATA 200 C / 400 C – Twisted Pairs. Continuous bending highly-flexible PVC data cables	30
<b>LIFE-LINE pre-assembled cables according to the INDRAMAT standard.</b> Even easier to order	31
<b>Innovative conveyors.</b> Intelligent design for fast service – new module connections	32
<b>WAVE-BELT hinged belts with optimized axis system.</b> Very easy to service thanks to modular axes.	33
<b>Replaceable wipers for telescopic covers.</b> Improved gliding characteristics and stability	34
<b>Extremely good gliding characteristics and very high robustness.</b> Our state-of-the-art components for telescopic covers	35
<b>Proven harness mechanics with new bearings.</b> Our state-of-the-art components for telescopic covers	36
<b>New standard color for conveyor systems.</b> Fresh colors for modern machine design	37
<b>KABELSCHLEPP worldwide.</b> Sales network	38

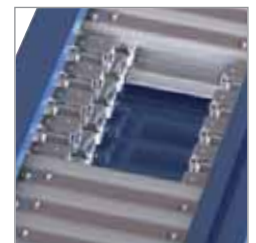
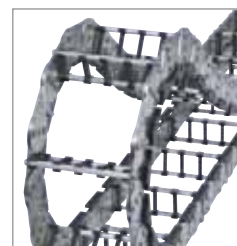

The new EasyTrax 0320.

# Simply press in the cables – extremely stable design.

With the new EasyTrax 0320 we are breaking new ground. The new cable carrier design makes it possible to combine apparently contradictory requirements: Firstly, the cable carrier should be very stable and have a large unsupported length. Secondly, for fast laying it should be possible simply to press cables in.

The new EasyTrax 0320 combines these requirements thanks to an innovative design and its combination of materials: hard carrier bodies of fiberglass-reinforced material with lamella crossbars of flexible special plastic.

What is more, the new lamella crossbars allow a very high utilization factor and the use of dividers for cable separation.

The integrated damping system makes the cable carrier particularly quiet.

BASIC-LINE PLUS



■ Intelligent 2-shot-design:  
Hard cable carrier body,  
soft crossbars.

## Dimensions

Type	$h_i$	$h_G$	Inside widths $B_i$				Outside width $B_k$
ET 0320	18	25.5	15*	25	38	50*	$B_i + 12$

Dimensions in mm

\* On request – please contact us.

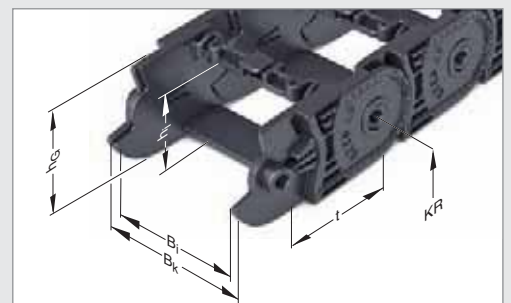

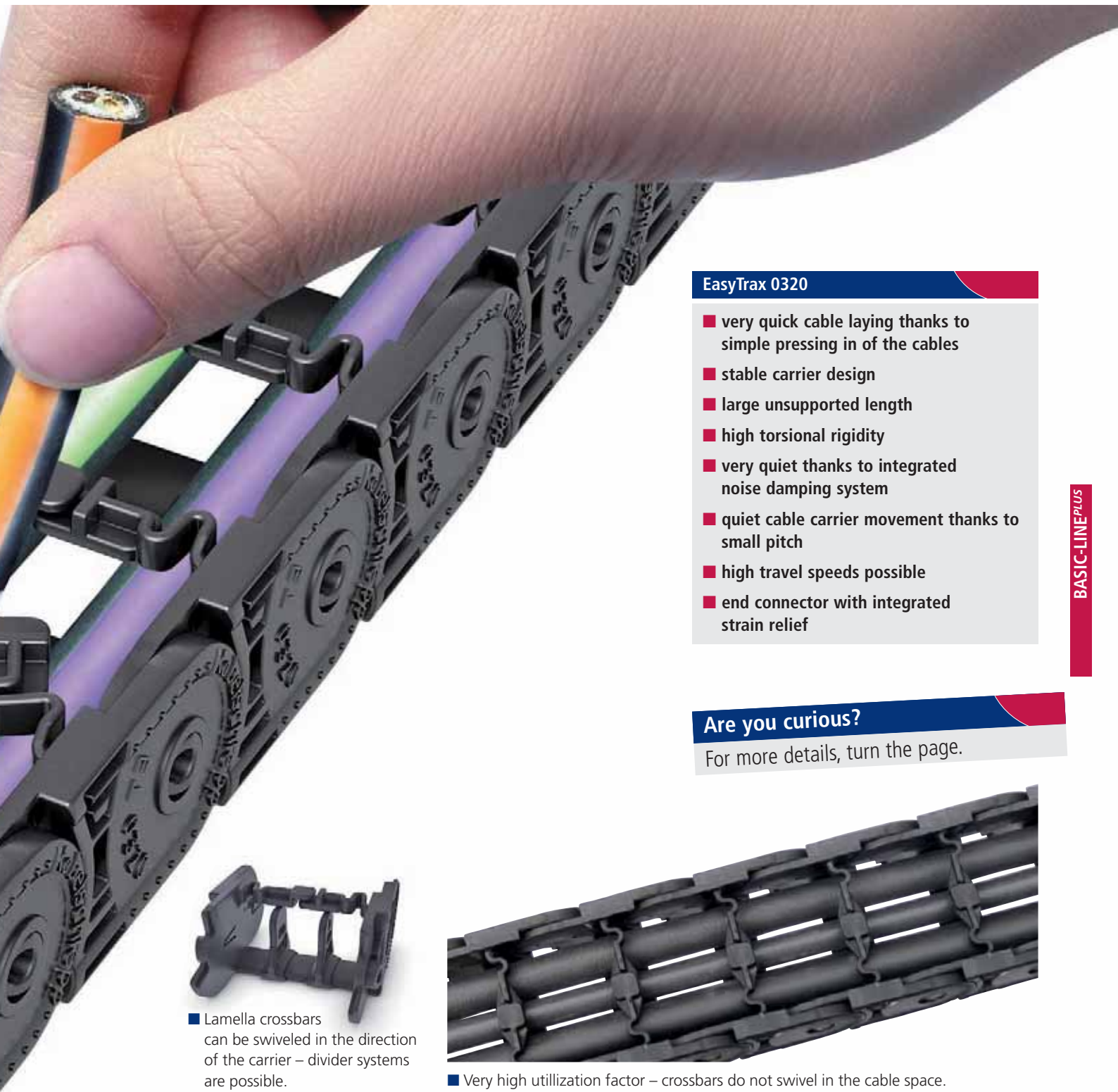

**EasyTrax 0320**

- very quick cable laying thanks to simple pressing in of the cables
- stable carrier design
- large unsupported length
- high torsional rigidity
- very quiet thanks to integrated noise damping system
- quiet cable carrier movement thanks to small pitch
- high travel speeds possible
- end connector with integrated strain relief

BASIC-LINEPLUS

**Are you curious?**

For more details, turn the page.

■ Lamella crossbars can be swiveled in the direction of the carrier – divider systems are possible.

■ Very high utilization factor – crossbars do not swivel in the cable space.

**Inside widths / Inside height**

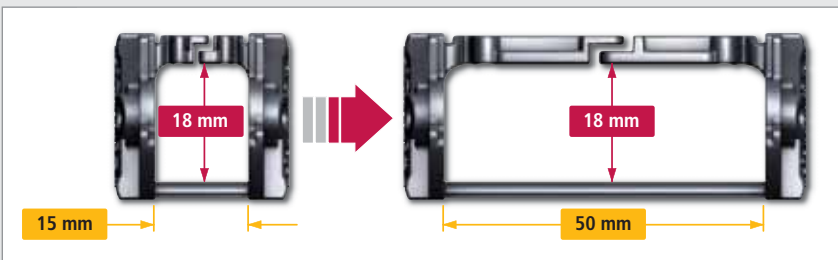

Bj 15 and 50 mm on request.

Subject to change.

**Bend radii KR**

Bend radii KR in mm			
28	38	48	75
100	125*		

\* On request – please contact us.

**Pitch t = 32 mm**

We are there for you! **Fon: +49 271 5801-0**



# The new EasyTrax 0320.

The 2-shot-technology.

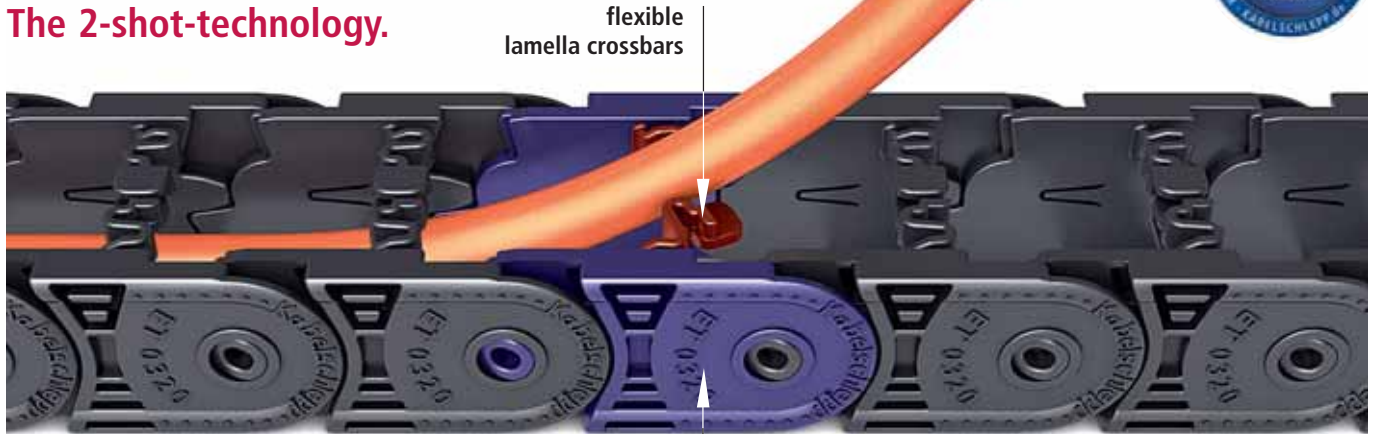

BASIC-LINE PLUS

Flexible lamella crossbar – simple pressing in of the cables

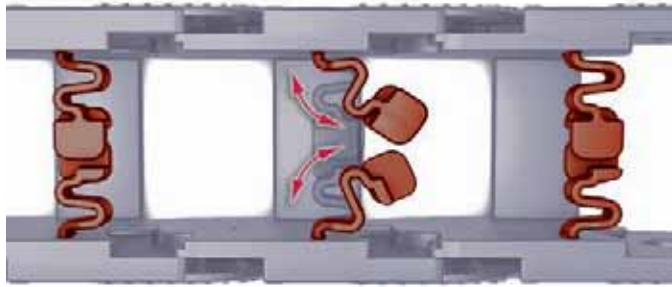

**High flexibility, high utilization factor – very quick cable laying thanks to simple pressing in of the cables.**

The elastic material of the lamella crossbar significantly shortens the assembly times. The cable carrier is laid **simply by pressing the cables in**.

The defined swivel direction in the direction of the cable allows a significantly **higher utilization factor** than in systems where cables are inserted into the cable space from above. The new crossbar design also allows the use of dividers for cable separation.



■ EasyTrax – very high utilization factor. Crossbar can be swiveled in the direction of the cable.

■ Unfavorable swivel direction of the crossbars in the cable space – cables already laid jam the crossbars.

hard chain link of fiberglass reinforced material

Fiberglass reinforced chain link – high stability



**High stability – long unsupported lengths thanks to fiberglass-reinforced material.**

The use of fiberglass reinforced special plastic in the supporting area of the cable carrier makes it possible to nearly double **the unsupported length** compared to designs manufactured entirely from non-reinforced materials.

**EasyTrax – long unsupported lengths.**



**Designs completely made of non-reinforced material – long unsupported lengths can only be implemented with sag.**

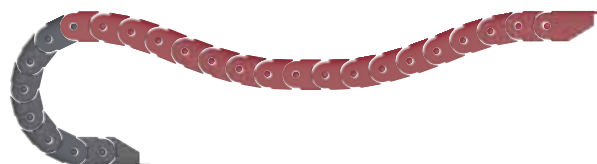

**High side stability through locking in the stroke system.**

The stops are locked in the bend radius stop and pretension stop. This prevents snapping out in these areas and achieves very high lateral stability.



**The right solution for every application.**

**Design 30**



Opens on the **outer radius**.

**Design 40**



Opens on the **inner radius**.

**Reliable cable separation.**

Lamella crossbars which can be swiveled in the direction of the cable carrier allow the use of divider systems for reliable cable separation. The special shaping with wrap-around means that the dividers sit firmly on the chain link.



**End connector with integrated strain relief comb.**

The cables can be fixed quickly and securely on the integrated strain relief comb.



**Different connection variants.**

Different connection variants are possible by simply changing the connectors.



**Easy connection with just a few manual operations.**

**1. Insert**



**2. Press together – done!**



The new QuickTrax 0320.

# Quick to open thanks to new film hinge.

The new QuickTrax 0320 ushers in the next generation of compact, cost-effective plastic cable carriers with 2-shot-technology. Thanks to the new crossbar system with a film hinge the cable carrier can be opened very quickly and easily for cable laying. Various designs allow opening on the inner or outer radius.

The integrated damping system reduces the impact noise and makes the QuickTrax 0320 an especially quiet cable carrier.

With the locking in the stroke system the QuickTrax 0320 has high lateral stability and is thus optimally suited for applications where the cable carrier is installed on its side and applications with high transverse acceleration.

BASIC-LINE



- Intelligent 2-shot-design:  
Hard carrier body, elastic film hinge.



## Dimensions

Type	$h_i$	$h_G$	Inside widths $B_i$				Outside width $B_k$
QT 0320	20	25.5	15*	25	38	50*	$B_i + 12$

Dimensions in mm

\* On request – please contact us.

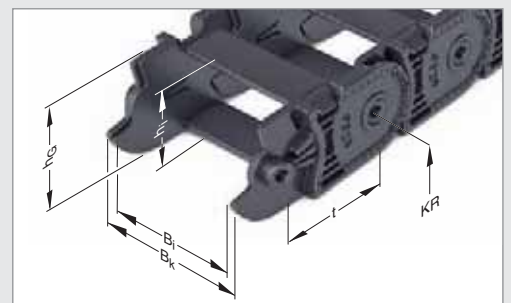





**QuickTrax 0320**

- new crossbar system for quick opening of the cable carrier
- crossbar securely connected to the chain link even when it is open
- extremely stable cable carrier design
- inside and outside opening designs
- large unsupported length
- high torsional rigidity
- very quiet thanks to integrated noise damping system
- quiet cable carrier movement thanks to small pitch
- high travel speeds possible
- end connector with integrated strain relief

BASIC-LINE

**Are you curious?**

For more details, turn the page.

■ Divider systems for reliable cable separation.

**Inside widths / Inside height**

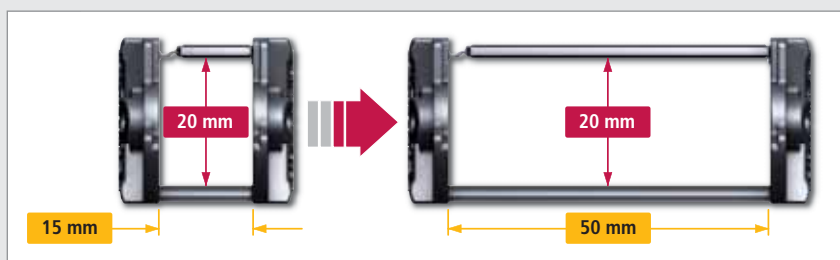

Bj 15 and 50 mm on request.

Subject to change.

**Bend radii KR**

Bend radii KR in mm			
28	38	48	75
100	125*		

\* On request – please contact us.

**Pitch t = 32 mm**

We are there for you! **Fon: +49 271 5801-0**



# The new QuickTrax 0320.

## The 2-shot-technology.

With its 2-shot-technology, the new QuickTrax 0320 combines two apparently contradictory requirements. The flexible material in the film hinge allows quick cable laying thanks to **lightning-quick opening and closing of the crossbar**. The carrier bodies of fiberglass reinforced material give the carrier extremely high stability and large unsupported lengths.

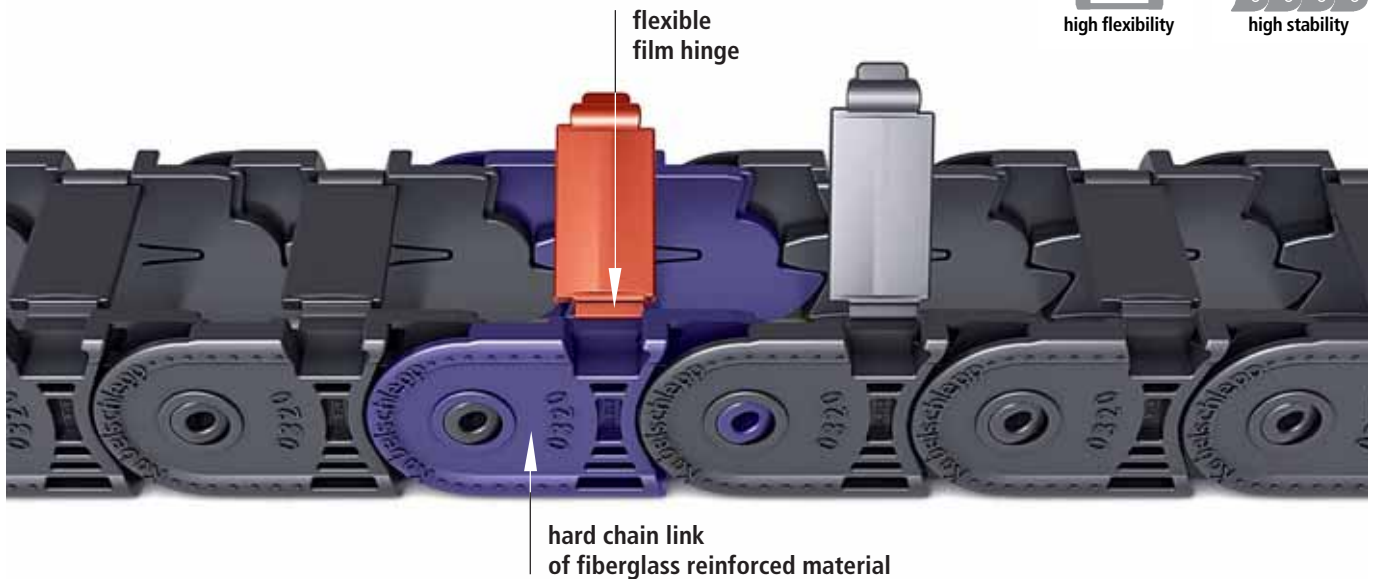

BASIC-LINE

## Fast opening, fast closing, faster work – crossbar with film hinge.

Simply release the crossbar on one side of the carrier and open it up with a single manual operation. The carrier is already open and ready for cable laying. The crossbars are connected to the carrier by a film hinge so that they cannot be lost, and thus remain attached to the chain link even when they are open.



## Hand opening – opening and closing even without tools.

Thanks to their special shaping and flexible material, the crossbars can be **unlocked very easily by hand**.

They can also be opened just as easily with a screwdriver.

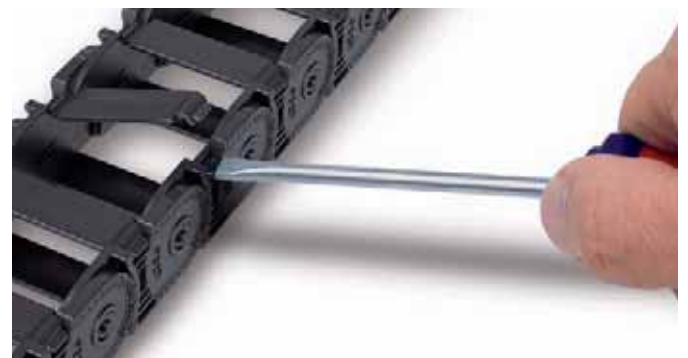

**The right solution for every application.**

**Design 30**



Opens on the **outer radius**.

**Design 40**



Opens on the **inner radius**.

**Reliable cable separation.**

Divider systems are available for reliable separation of cables. The special shaping with wrap-around means that the dividers sit firmly on the chain link.



**High side stability through locking in the stroke system.**

The stops are locked in the bend radius stop and pretension stop. This prevents snapping out in these areas and achieves very high lateral stability.

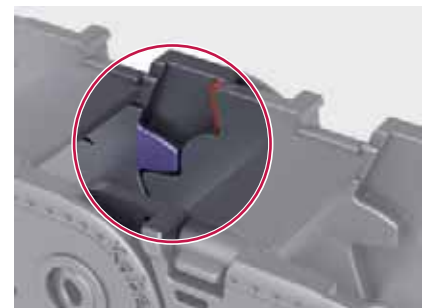
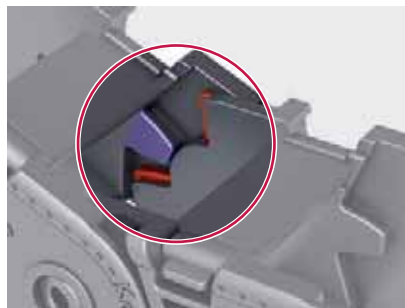

BASIC-LINE

**End connector with integrated strain relief comb.**

The cables can be fixed quickly and securely on the integrated strain relief comb.



**Different connection variants.**

Different connection variants are possible by simply changing the connectors.

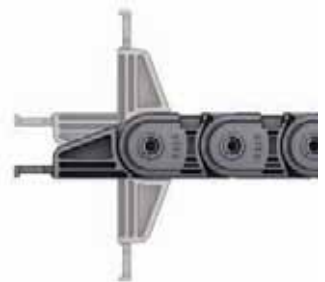

**Easy connection with just a few manual operations.**

**1. Insert**



**2. Press together – done!**



The new UNIFLEX 1665 with 44 mm inside height.

# Lighter, quieter, more effective.

New **generation** – new **designation**

## 0665 **1665** UNIFLEX UNIFLEX *Advanced*

The new generation of our cost-effective, light and quiet UNIFLEX series now comes in a new size. The optimized geometry makes the cable carrier very stable and robust.

BASIC-LINE

Like the other types, the UNIFLEX 1665 is weight-optimized, and the integrated damping system makes the cable carrier very quiet. For cable laying, the crossbars with ball joint can be opened quickly and easily.

All of this makes the UNIFLEX 1665 another cost-effective **all-rounder with a wide range of possible applications.**

### UNIFLEX *Advanced* – types

The proven **UNIFLEX *Advanced*** has been expanded with the type 1665.

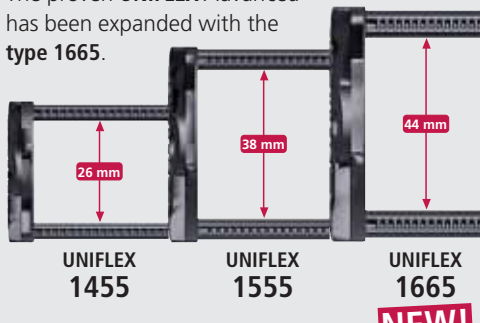

### Dimensions

Type	h <sub>i</sub>	h <sub>G</sub>	Inside widths B <sub>i</sub>				Outside width B <sub>k</sub>
UNIFLEX 1665	44	60	50*	75	100	125	B <sub>i</sub> + 22
			175	200*	225*	250*	

Dimensions in mm

\* On request – please contact us.

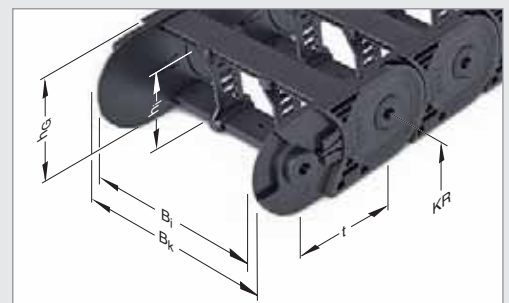



■ Design 020:  
Single-part chain links –  
simple, cost-effective, sturdy.

**UNIFLEX 1665**

- cost-effective cable carrier
- single-unit or openable designs
- lighter thanks to optimized geometry
- very quiet thanks to noise damping system
- large unsupported length
- large additional loads
- torsionally rigid
- for unsupported and gliding applications and applications where the cable carrier is installed on its side
- end connectors with integratable strain relief

BASIC-LINE

**Are you curious?**

For more details, turn the page.

**Inside widths / Inside height**

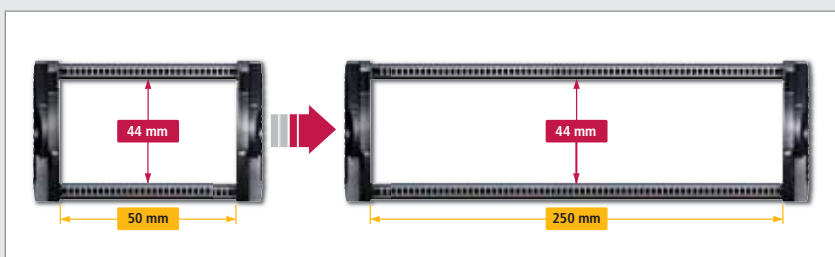

B; 50, 200, 225 and 250 mm on request.

Subject to change.

**Bend radii KR**

Bend radii KR in mm			
75	100	120	140
200	250*	300*	

\* not for B; 75 and 150 mm

**Pitch t = 66.5 mm**

We are there for you! **Fon: +49 271 5801-0**

# The new UNIFLEX 1665.

## Lighting-quick and easy opening.

### Crossbar of the new UNIFLEX 1665.

The crossbars in designs 030 and 040 are based on a ball joint mechanism that allows quick and easy opening (on the right/left).

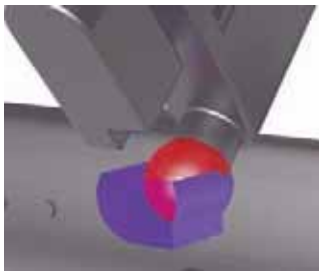

■ Crossbar with ball joint.



■ Simply turn crossbar and open up.

■ Particularly practical: The crossbar remains attached to the link even when open.



■ If necessary, the crossbar can be detached from the chain link simply by turning it.

BASIC-LINE

## Dividers for greater stability – even with large carrier widths.

### Dividers remain securely attached to the carrier.

The special shaping of the dividers means that they also remain firmly connected to the detachable crossbar. This makes wide carriers even more stable.

Turning the crossbars out ensures that the dividers remain securely in the carrier when opening.



## An optimal solution for every application – different opening variants.

### Design 020 single-part links



- Single-part plastic chain links, not openable, thus even greater stability
- **Cost-effective solution**
- For extreme challenges, e.g. laying hydraulic hoses with small bend radii

### Design 030 opens on the outside



**Outside:** openable (on the right/left) and detachable.

### Design 040 opens on the inside



**Inside:** openable (on the right/left) and detachable.

**Ideal for applications where the carrier is installed on its side.**

Lateral wear surfaces guarantee a long service life.

For applications where the cable carrier is installed on its side or gliding in a guide channel, the lateral wear surfaces ensure an **even longer service life**.



**Various separation options for the cables.**

**Movable dividers**

The standard dividers (divider version A) are movable.



■ Movable dividers without arresting cams.



■ Divider system TS 1 with continuous height subdivision.



■ Divider system TS 3 with plastic partitions.

**Fixable dividers**

for arrangements where the carrier is installed on its side and applications with high transverse accelerations.

The dividers (version B) can be fixed at 2.5 mm steps **without any additional spacers**. This is achieved by the arresting cams becoming secured in the locking profile of the crossbar.



■ Locking profile and arresting cams.



BASIC-LINE

**Easy connection with optional strain relief comb.**

With plastic UMBs (Universal Mounting Brackets), you can connect the new UNIFLEX types very easily from **above**, from **below** or **at the front**.

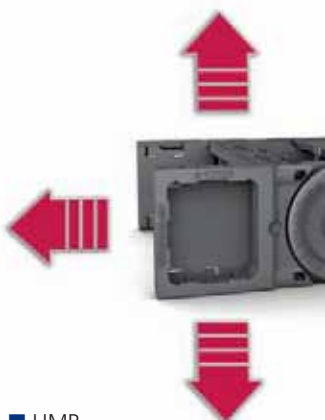

■ UMB – Universal Mounting Bracket.



■ Universal Mounting Brackets with strain relief LineFix, mounted on C-rail.



■ Fixing in the UMB.



■ Optional: strain relief comb on both sides.

LineFix saddle-type clamps.

# Reliable cable fixing.

With our newly-developed LineFix saddle-type clamps you can fix your cables simply and securely. Design details such as the optimized base geometry and the way that the pan elements are gentle on the cables make our new saddle-type clamps a reliable solution.

All types and sizes are available ex stock!

LineFix



LineFix saddle-type clamps

- optimized base geometry for secure seating in the C-profile
- high quality corrosion protection of the coated housing through cathode immersion painting
- pan design with retaining ribs for secure fixing of the cables
- rounded design of the pan elements is gentle on the cables
- new press pan design through optimized press pan geometry
- high-quality design with black housing, setscrews and pans

## Secure seating and easy assembly.

The retaining lug fixes the base securely in the C-profile in the screwed-on state and **prevents the clamp from rocking out** in case of tensile and compressive loads, regardless of the installation direction.

With saddle-type clamps without a retaining lug the base is held only via clamping to the inside of the rail. If strong tensile loads cause it to shift in the direction shown below, one side of the base may rock out of the C-rail.

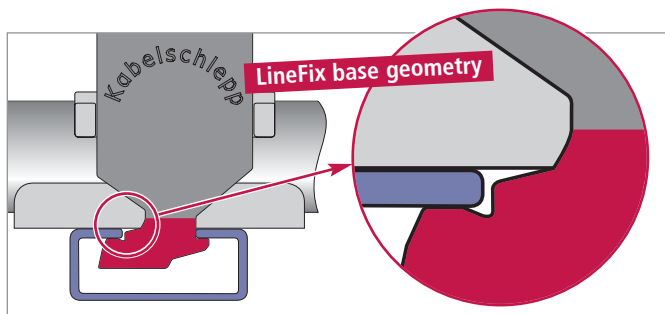

■ LineFix – secure seating with clamping and retaining lug.

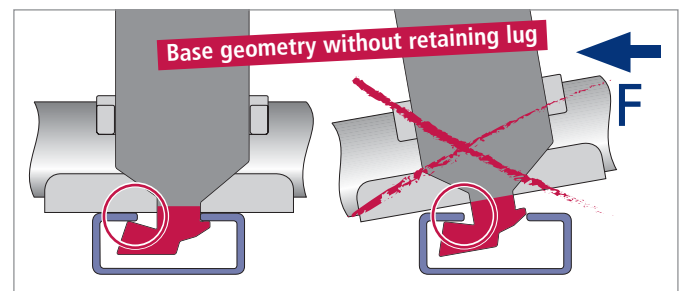

■ Fixing only via clamping to the underside of the rail.

## New press pan design through optimized press pan geometry.

The curved retaining ribs in the pans **fix the cables very gently and securely.**

Guides on both sides of the press pan secure it against slipping out of the clamp.

■ Curved retaining ribs.

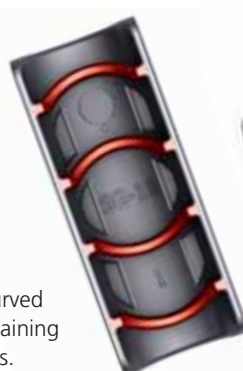

■ The press pan is secured against slipping out of the clamp regardless of the installation direction.







Easy to install even in cramped installation spaces with hexagon socket stud.



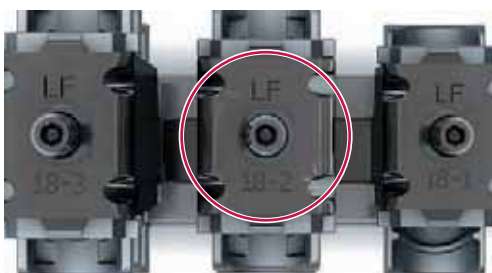

■ When fixing, position the new LineFix saddle-type clamps using the retaining lug. They will be aligned automatically.

**Size can be identified in the installed state.**



■ Labeling with size designation on the top of the clamp.

LineFix Type	Designation	Material no. for a complete LineFix	Min. cable Ø	Max. cable Ø	Number of cables	Width	Total height with max. cable Ø incl. C-rail
 Single clamps	LF 12-1	13630	6	12	1	16	55
	LF 14-1	13631	12	14	1	18	52
	LF 16-1	13632	14	16	1	20	54
	LF 18-1	13633	16	18	1	22	56
	LF 20-1	13634	18	20	1	24	59
	LF 22-1	13635	20	22	1	26	61
	LF 26-1	13636	22	26	1	30	70
	LF 30-1	13637	26	30	1	34	74
	LF 34-1	13638	30	34	1	38	78
	LF 38-1	13639	34	38	1	42	82
	LF 42-1	13640	38	42	1	46	91
 Double clamps	LF 12-2	13641	6	12	2	16	73
	LF 14-2	13642	12	14	2	18	74
	LF 16-2	13643	14	16	2	20	82
	LF 18-2	13644	16	18	2	22	86
	LF 20-2	13645	18	20	2	24	91
	LF 22-2	13646	20	22	2	26	95
	LF 26-2	13647	22	26	2	30	108
	LF 30-2	13648	26	30	2	34	121
	LF 34-2	13649	30	34	2	38	129
	 Triple clamps	LF 12-3	13650	6	12	3	16
LF 14-3		13651	12	14	3	18	98
LF 16-3		13652	14	16	3	20	105
LF 18-3		13653	16	18	3	22	111
LF 20-3		13654	18	20	3	24	118
LF 22-3		13655	20	22	3	26	130

LineFix

MC 1300 – new stay variant with ball joint.

## Lightning-quick and easy to open.

With the new ball joint stay variant you can install cables in the MC 1300 **even more efficiently**. The new stays with ball joint can be opened quickly and easily.

WIDTH SECTIONS



### MC 1300 with ball joint

- can be quickly opened on the inside and outside for cable laying
- available in 1 mm width sections
- carrier widths up to 800 mm possible

VARIO-LINE



### Can be opened quickly with ball joint.



■ Unlock stay on both sides, turn it ...



... and open up.



■ The stay remains on the chain link even when open.



■ The stay can also be detached from the chain link if necessary.

### Extremely stable connection.



■ Extremely stable ball joint for holding the stay reliably in the chain link.



■ Positive connection – robust detent lug.

### Can be opened on the inside and outside.

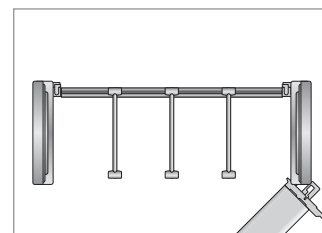
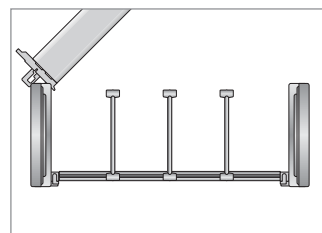

■ Can be opened on the inside and outside – dividers remain in the carrier on the closed stay.

### Divider systems.

The proven divider systems of the MC 1300, stay variant RMF can be used. The dividers can be fixed with fixing strips.



### Dividers have a secure hold when opening.

The special shaping of the dividers means that they remain firmly connected to the inner and outer stay. When the stays – **inner or outer** – are opened, it is guaranteed that the dividers will remain on the carrier.



MT 1300 with aluminum cover system.

# Stable, robust, 1 mm sections.

The new aluminum cover system of the MT 1300 is **extremely stable** and **protects** the cables in the cable carrier **from machining chips and coarse contamination**.

The covers are very gentle support for the cables and provide high stability with low weight. They are fastened with a screw on each side and can be detached quickly inside and outside.



### MT 1300 with aluminum cover system

- aluminum cover system for protecting the cables and hoses
- available in 1 mm width sections
- ideal protection from coarse contamination and machining chips
- aluminum covers are also optimally suited for extremely hot metal chips
- very stable cover
- can be opened on the inside and outside for cable laying
- carrier widths up to 800 mm possible

VARIO-LINE

## Easy to open inside and outside, dividers have a secure hold when opening.

Whether you open the carrier on the inner or outer radius, turning the cover ensures that the dividers remain securely attached to the carrier.

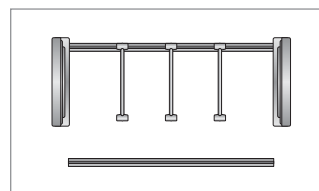
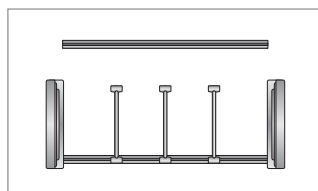

## Divider systems for separating the cables.

With the proven divider systems of the MC 1300 you can also separate the cables in the MT 1300.



■ Divider system TS 0



■ Divider system TS 1 with additional continuous height subdivision.



■ Divider system TS 3 with plastic partitions.



■ Divider system TS 3 with aluminum partitions.

## A reliable solution for all applications where the carrier is installed on its side.

Also ideally suited for applications where the carrier is installed on its side and for applications with extreme transverse accelerations (fixable dividers).

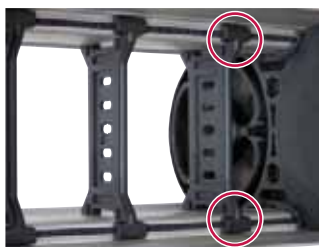

■ Fixing on both sides in 4 mm steps ensures that the dividers have a secure hold.



■ The fixing profiles are simply pushed into the cover.

# MINI 0152

Re-design of the MINI 0150.

## Compact, stable, easy to fill.

New **generation** – new **designation**

**0150** → **0152**  
MINI MINI

Our compact cable carriers have been redesigned to make them even better.

The outer contours have been reworked to improve the ratio of inner to outer width still further. That means that **even less installation space** is needed for the same inner dimensions.

The proven tubular geometry makes the new MINI 0152 extremely stable.

BASIC-LINE



### MINI 0152

- compact inner dimensions  
Ø = 7 mm
- light and cost-effective
- extremely stable due to tubular geometry
- cables can be pushed in quickly and easily
- quiet, low-vibration operation
- optimized cable protection, because upper trough closed to the outside
- modern design

### Cables can be pushed in easily.

In very small cable carriers with rectangular cross-sections the cables often strike against the crossbars when they are pushed in.

The new MINI 0152 has a round carrier cross-section. The smooth interior prevents the cables from catching on the chain links; the **cables can be pushed into the cable carrier very quickly and easily.**

■ Tubular shape means the cables can be pushed in easily.

### Dimensions

Type	h <sub>i</sub>	h <sub>G</sub>	Inside width B <sub>i</sub>	Outside width B <sub>k</sub>
MINI 0152	7	10	7	12

Dimensions in mm

Bend radius KR = 15 mm

Pitch t = 15 mm

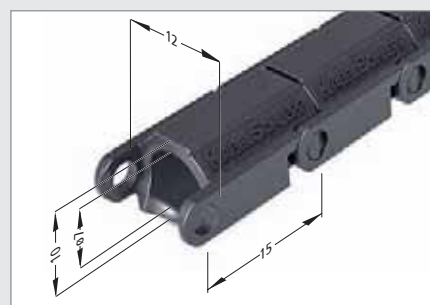

UNIFLEX 1455 with external dampers.

# Reducing rolling noise.

The new external dampers effectively reduce the rolling noise of the UNIFLEX 1455.

The use of external dampers is particularly recommendable for support trays and guide channels that are only attached at points and hence form a resonating body.



**UNIFLEX 1455 with external dampers**

- new damping elements in the outer area to reduce rolling noise in the guide channels and support trays
- inner noise dampers to reduce impact noise

■ Easy to install; the dampers are securely held against the crossbars.

BASIC-LINE

New divider systems for MC/MT 0950/1250.

# New separation options.

For the aluminum cover system RMD and the solid frame stay RM of the types MC/MT 0950/1250, new divider systems for separating the cables are available immediately. In addition to the divider system TS 0 already available, the TS 1 with continuous height subdivision and TS 2 with section subdivision of aluminum are now available.



VARIO-LINE

**Optimal use of installation space – with stays and height separators made of aluminum.**

Carrier and chamber widths in 1 mm width sections.



■ Stay variant RM with TS 1.



■ Stay variant RM with TS 2.



■ Stay variant RMD with TS 1.



■ Stay variant RMD with TS 2.

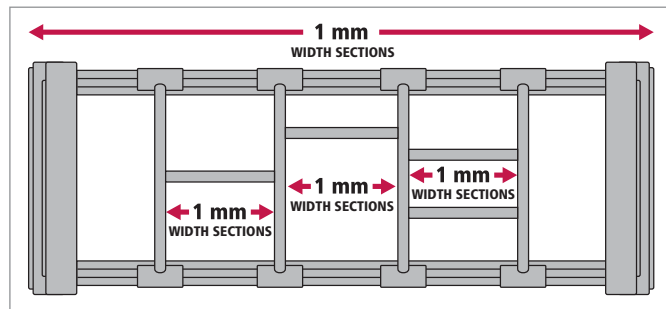

# MASTER LC 80

MASTER LC 80 with new frame stays.

## Easy-to-fit, sturdy, robust, fixable dividers.

The new frame stays of the MASTER LC 80 make this cable carrier **even easier to fit and more robust.**



The fixable dividers allow the MASTER LC 80 to be used in even more applications.

### Dividers have a secure hold when opening.

The special shaping of the dividers means that they remain firmly connected to the inner and outer stay. When the stays – **inner or outer** – are **opened**, a rotation guarantees that the dividers will remain on the cable carrier.



### Also for applications where the cable carrier is installed on its side.

Also highly suitable for applications where the cable carrier is installed on its side and for transverse accelerations.



- Fixing on both sides ensures that the dividers have a secure hold.
- Fixing in 3 mm sections.
- The fixing profiles are simply pushed into the stays.



#### New frame stays MASTER LC 80

- robust and stable thanks to optimized stay geometry – for cable carrier widths up to 800 mm
- quick and easy release for cable laying
- fixed dividers for applications where the cable carrier is installed on its side and applications with transverse accelerations

### Can be opened on the inside and outside.

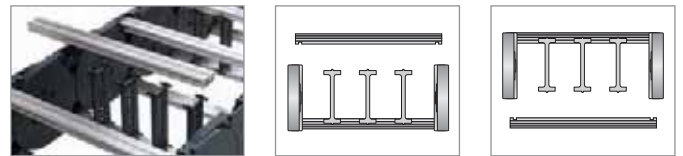

- Can be opened on the inside and outside – dividers remain in the cable carrier on the closed stay.

### Proven divider systems for separating the cables.

With the proven divider systems of the MASTER LC 80 for separating the cables, you can also organize the inside of the cable carrier.



- Divider system TS 0 with vertical partitions.



- Divider system TS 1 with continuous horizontal height subdivision.



- Divider system TS 3 with partitions for challenging separations.

Online configuration for KABELSCHLEPP cable carrier systems.

# With just a few clicks of the mouse to an optimal KABELSCHLEPP cable carrier system.

Using the **OnlineEngineer** you can **quickly, dependably and flexibly** design the KABELSCHLEPP cable carrier system with the optimal price/performance ratio!

## Laying out your cable carrier system with the OnlineEngineer.

Just input the parameters of your application and the OnlineEngineer will **automatically calculate** the KABELSCHLEPP cable carrier system with the **optimal price/performance ratio!**

Alternatively you can follow the **step-by-step** menus and individually design your desired cable carrier system.

If you already know which KABELSCHLEPP cable carrier system you would like to employ just enter the order specifications and you will receive all applicable information by mouse click.

The distribution of the carriers with a chain cross-section can also be defined easily. With the click of the mouse you'll receive a to-scale **diagram in CAD format**.

Any and all functions can be combined so that it will only be necessary for you to enter the required information once and so that you can remain flexible in your design.

As soon as you have laid out your cable carrier you can **download** a corresponding **2D diagram or a 3D model**.

In order to further simplify the layout of our cable carrier in the future we will continue the development of this 1st Edition of the OnlineEngineer. We will be presenting interesting new functions to you soon.

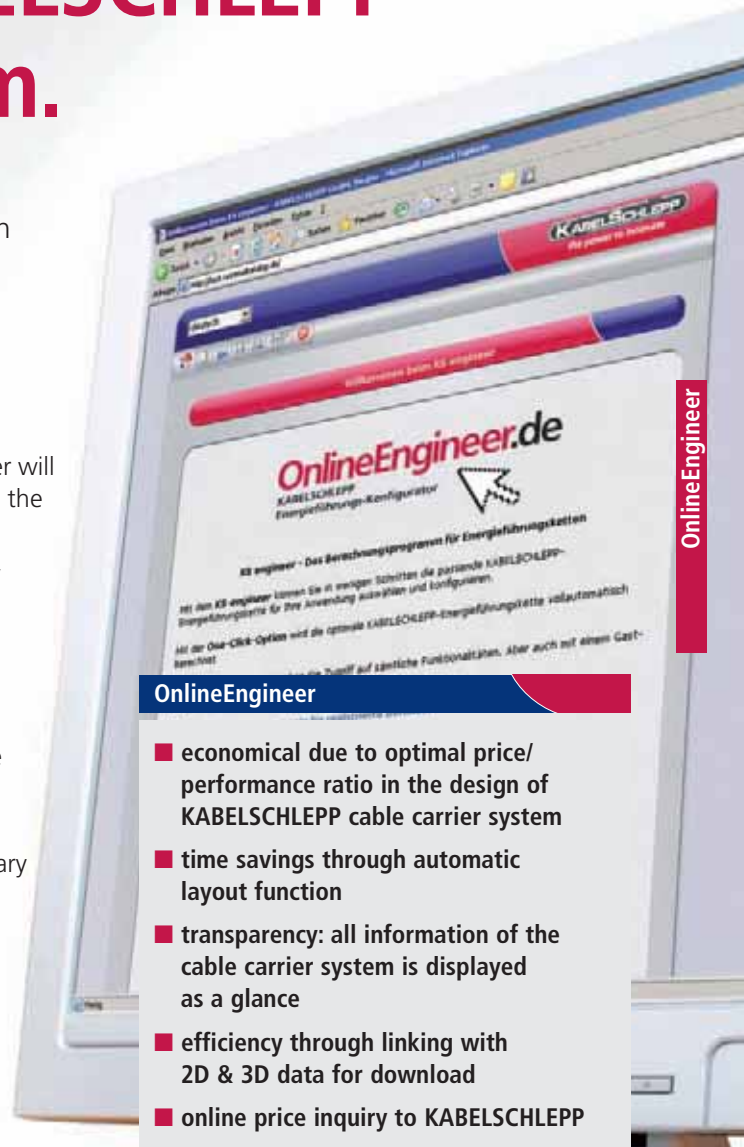

### OnlineEngineer

- **economical due to optimal price/performance ratio in the design of KABELSCHLEPP cable carrier system**
- **time savings through automatic layout function**
- **transparency: all information of the cable carrier system is displayed as a glance**
- **efficiency through linking with 2D & 3D data for download**
- **online price inquiry to KABELSCHLEPP**

**OnlineEngineer**  
[www.online-engineer.de](http://www.online-engineer.de)

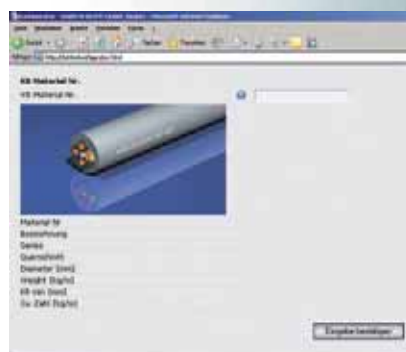

LS/LSX 1050 with mounting frame stay.

## Routing large cables reliably.

Often cables with a very large diameter and a low intrinsic weight, such as air hoses, have to be routed. In such cases our light steel carrier LS/LSX 1050 with mounting frame stay (RMA) is the ideal choice.

This stay system makes it possible to route cables whose diameter is larger than the inside height of the chain links.

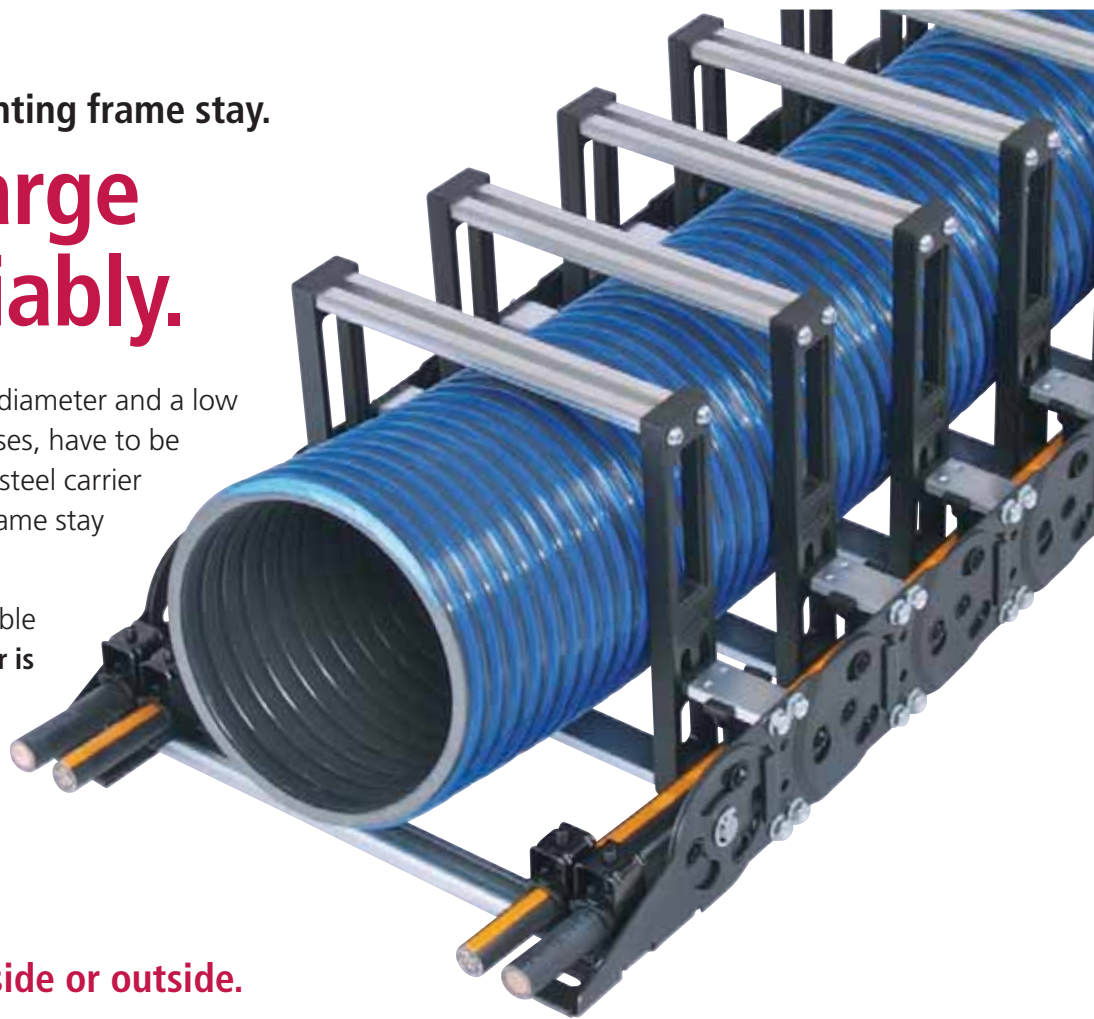

STEEL-LINE

### Can be fitted either inside or outside.

Depending on the installation situation, the mounting frame stays can be mounted either on the inner or outer radius.

With mounting on the outer radius the chain bands are supported by lateral support surfaces.



### Additional chambers for other cables.

Routing of additional cables with small diameters such as electrical or hydraulic cables is possible in the chambers on the sides.

Dividers can be used for additional separation of the cables.



### Different inside heights for different cable diameters.

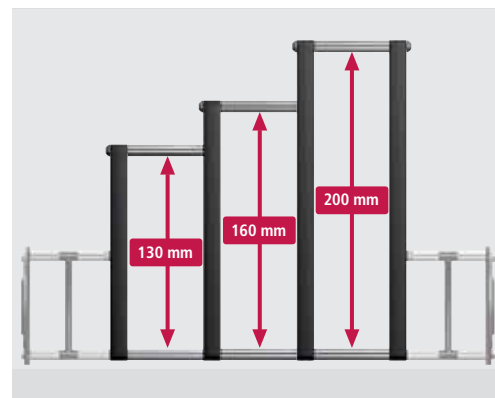



Glide shoes for S/SX 0950 as a standard injection-molded part.

# Steel carrier in a gliding arrangement.

The glide shoes for the series S/SX 0950 are also available immediately as a standard injection-molded part. The new standard glide shoes are manufactured from **highly abrasion-resistant special plastic** with low coefficients of sliding friction.

### Glide shoes for S/SX 0950

- cost-effective
- long service life thanks to highly abrasion-resistant special plastic and large wearing volume
- lower coefficient of sliding friction
- easy inspection of the wear state
- easy replacement with screw connection
- can be used with all stay variants

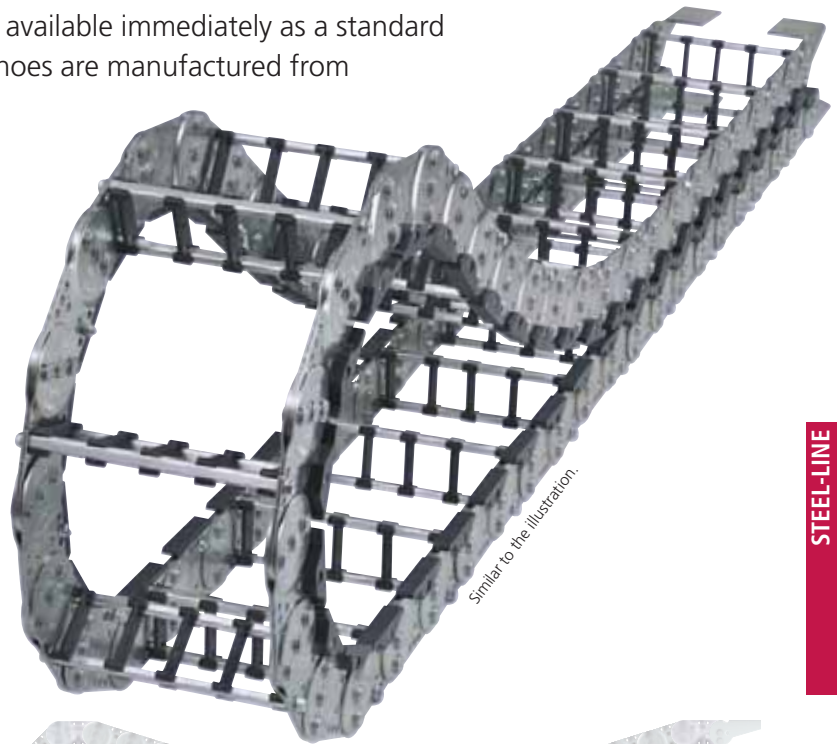

STEEL-LINE

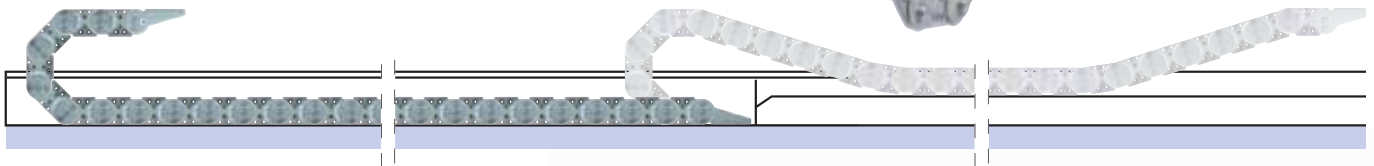

■ Schematic illustration of a steel cable carrier in gliding arrangement with glide shoes.

## Easy replacement with screw connection.

In the case of cable carriers in gliding arrangement, the gliding surfaces are exposed to particularly heavy loads and are as a rule the main wearing part.

The lateral wear markings on the new glide shoes allow easy inspection of the wear state at any time. When wear occurs the **glide shoes can simply be replaced**.

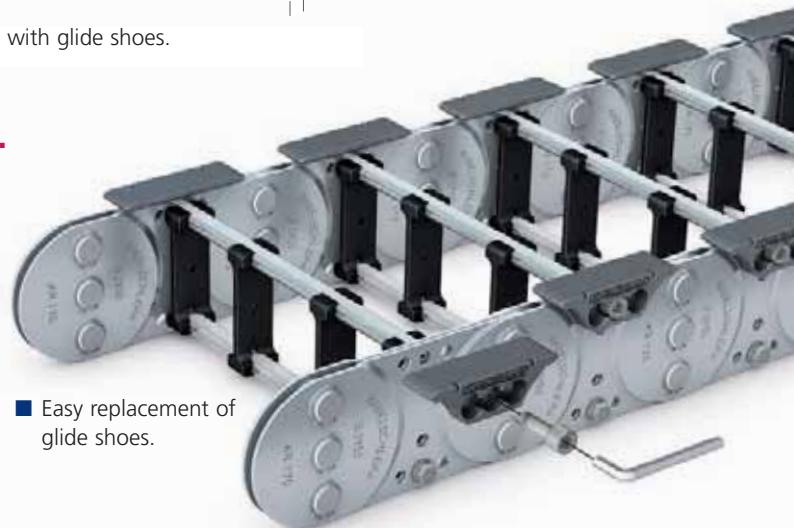

■ Easy replacement of glide shoes.



■ Easy inspection of the wear surfaces with wear markings.

ECC – Emergency Cable Carrier.

# Safety for long travel lengths.

Blockages in the travel lengths of cable carriers in large systems can destroy the entire cable carrier system. This results in high costs and downtime for the entire system. The new **ECC – Emergency Cable Carrier minimizes downtimes and avoids repair costs.**

The new **Emergency Cable Carrier System with additional emergency stop system** has been developed especially for systems with long travel lengths.



In applications in harsh environmental conditions it often happens that an object gets into the travel length of the carrier and blocks it. What is needed here is a system that detects such blockages and switches the system off. However, in large systems the moving mass is very large, which means that the moving unit continues to move for several meters even after braking is initiated. This leads to defects in the carrier, a complete failure of the system and extensive repair work. Our new decoupling system for cable carriers offers, in addition to the emergency stop function, also a **bridging safeguard for the braking distance.**

**Possible areas of application:** all applications with long travel lengths, e.g.: crane, port, compost or coal conveyor systems, steel works and raw materials systems.



■ Emergency Cable Carrier on a Rail Cable Carrier. The system can also be adapted for gliding arrangements.

## RCC Rail Cable Carrier System

RCC – our proven system for very long travel lengths. The use of a roller system reduces the forces needed to move the carrier by about 90 % compared to gliding arrangements. The combination of the Rail Cable Carrier System and the new Emergency Cable Carrier System is a very reliable solution even for extremely long travel lengths up to 500 m.

ECC – Emergency Cable Carrier

## Emergency Cable Carrier System – a possible installation situation.



## Cable carrier with emergency system – cable routing.

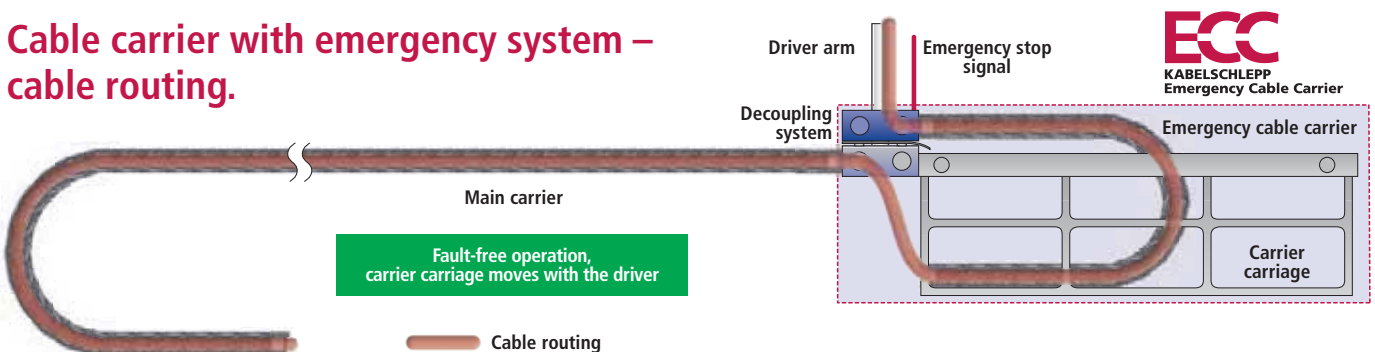

# ECC – Emergency Cable Carrier

## Decoupling system with automatic emergency cutout.

Our new Emergency Cable Carrier System offers, in addition to a bridging safeguard for the braking distance with an emergency carrier also an integrated emergency stop system.

The system is switched off if the preset maximum force on the driver of the main cable carrier is exceeded.

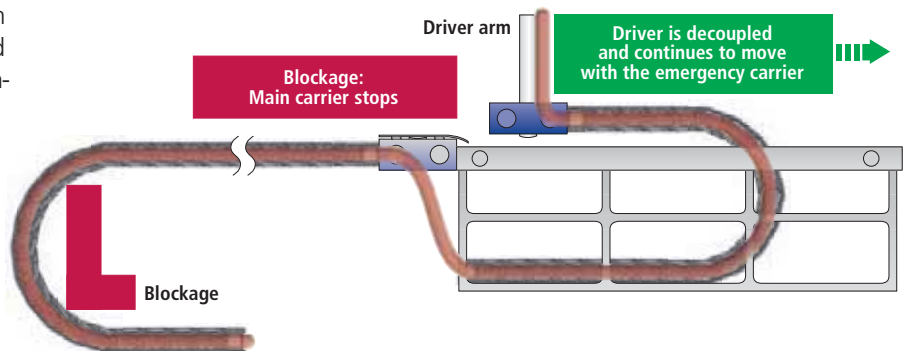

## Fault safeguard for both directions of travel.

Travel length of the emergency carrier in the event of blockage of the main carrier in the **PULLING DIRECTION**

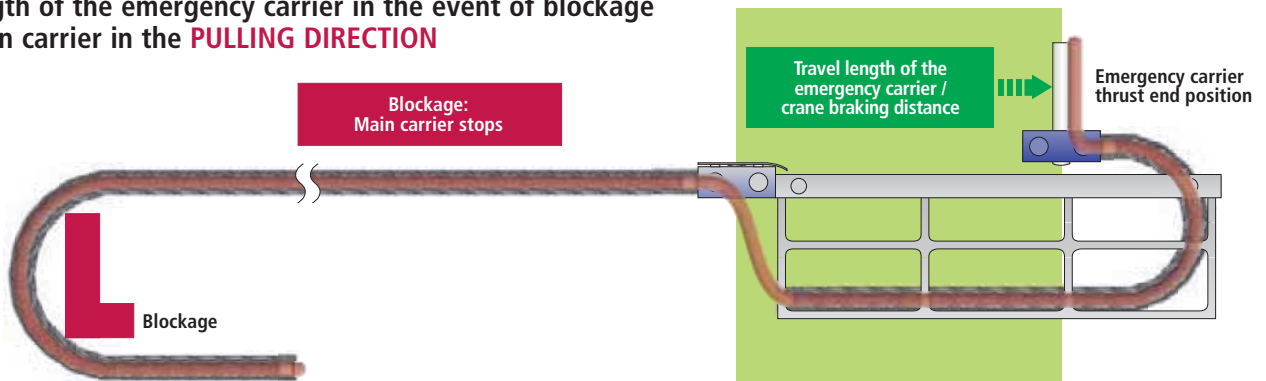

Travel length of the emergency carrier in the event of blockage of the main carrier in the **PUSHING DIRECTION**

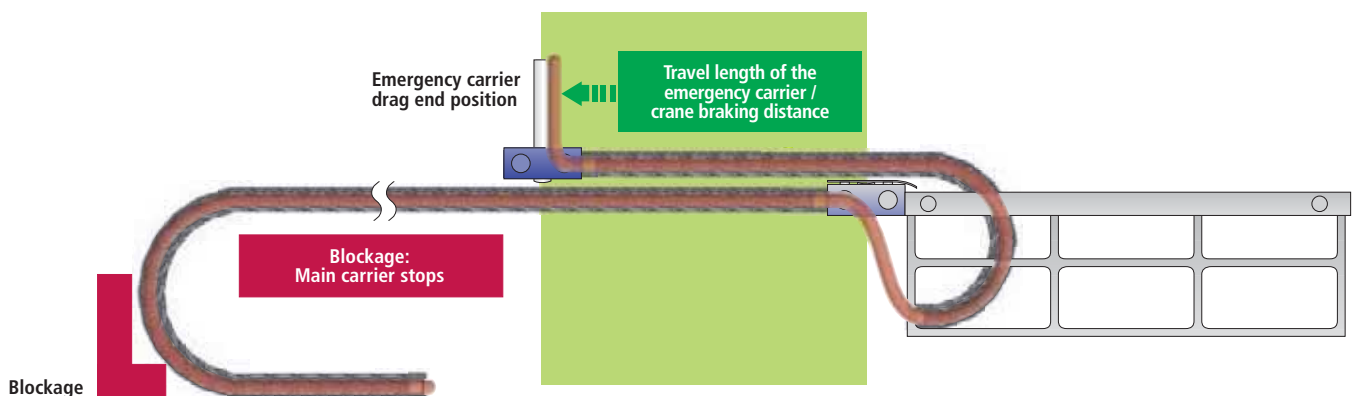

## Easy coupling.

If a fault has occurred that has caused emergency braking and decoupling of the system, then after the fault is eliminated all that has to be done is to re-couple the system.

The system is **ready for operation again immediately**.

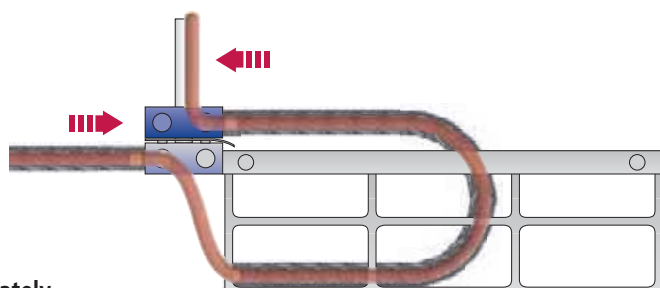

ECC – Emergency Cable Carrier

LIFE-LINE Power ONE 700 PE.

Continuous bending highly-flexible PUR single-core cables.

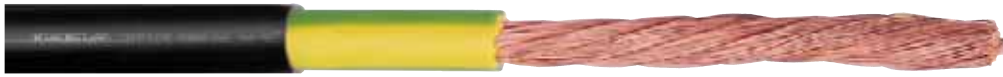

Similar to the illustration.



**HIGHLIGHT**

Extremely abrasion-resistant, UV-resistant outer jacket

**HIGHLIGHT**

Hi-flex core insulation, green/yellow acc. to VDE

**HIGHLIGHT**

Continuous bending hi-flex special cable

**Cable design**

- Conductor:** extra-fine wire conductor made from bare copper wires, design-optimized for maximum flexural strength
- Core insulation:** KS-TPM
- Core identification:** yellow/green
- Jacket:** KS-PUR
- Jacket color:** black

**Technical Data**

- Temperature range:** – 30 to + 90 °C
  - Minimum bend radius moved\*:** KR min  $\geq 7.5 \times \varnothing$
  - Insulation resistance:**  $\geq 30 \text{ M}\Omega \times \text{km}$
  - Voltage:** acc. to VDE 0.6 / 1 kV; acc. to UL/CSA 80 °C 1 kV
  - Approvals:** UL, CSA, based on VDE
- \* smaller bend radii are possible in many cases – contact us about options



LIFE-LINE Safety Cables

Core number x nominal cross-section in mm <sup>2</sup>	Part no.	Outer diam. max. in mm	Weight kg/m	Cu index kg/m
1 x 6 <sup>2</sup>	47583	7.2	0.085	0.060
1 x 10 <sup>2</sup>	47584	8.5	0.130	0.100
1 x 16 <sup>2</sup>	47585	10.0	0.195	0.154
1 x 25 <sup>2</sup>	47586	11.4	0.280	0.240

**LIFE-LINE Power ONE 700 PE**

- oil-resistant
- UV-resistant
- CFC-free
- halogen-free
- flame-retardant
- silicone-free
- RoHS-compliant

LIFE-LINE USB 700 CD – new design for an even smaller minimum bend radius.

Continuous bending highly-flexible USB PUR cable.



Similar to the illustration.



**HIGHLIGHT**

Extremely abrasion-resistant, UV-resistant outer jacket

**HIGHLIGHT**

Continuous bending hi-flex braided copper shield designed for small bend radii

**HIGHLIGHT**

High-strength specialized glide films for long endurance

**HIGHLIGHT**

Element shield and element jacket for reliable data transfer

**Cable design**

- Conductor:** extra-fine wire conductor made from bare copper wires, design-optimized for maximum flexural strength
- Core insulation:** KS-TPM
- Core identification:** colored, red, black/white, white, green
- Core stranding:** cores stranded type-optimized in short pitches with low torsion
- Shielding:** 90 % coverage
- Jacket:** KS-PUR
- Jacket color:** black

**Technical Data**

- Temperature range:** – 5 to + 50 °C
- Minimum bend radius moved:** KR min  $\geq 3 \times \varnothing$
- Insulation resistance:**  $\geq 200 \text{ M}\Omega \times \text{km}$
- Voltage:** acc. to VDE 30 V, acc. to UL 30 V
- Approvals:** UL, based on VDE



Core number x nominal cross-section in mm <sup>2</sup>	Part no.	Outer diam. max. in mm	Weight kg/m	Cu index kg/m
((1 x 2 x 26 AWG) + 2 x 20 AWG)	45687	6.7	0.070	0.038

**LIFE-LINE USB 700 CD**

- oil-resistant
- UV-resistant
- CFC-free
- flame-retardant
- silicone-free
- RoHS-compliant

**LIFE-LINE system cables.**

**Continuous bending highly-flexible PUR signal cables.**



Similar to the illustration.



**HIGHLIGHT**

Extremely abrasion-resistant, UV-resistant outer jacket

**HIGHLIGHT**

Continuous bending hi-flex braided copper shield designed for small bend radii

**HIGHLIGHT**

Cores stranded in very short pitches

**Cable design**

- Conductor:** extra-fine wire conductor made from tin-plated (46505) or bare copper wires (46090), design-optimized for maximum flexural strength
- Core insulation:** KS-TPM
- Core identification:** acc. to Heidenhain system (46505) acc. to Baumüller system (46090)
- Core stranding:** cores stranded type-optimized in short pitches with low torsion
- Shielding:** 85 % coverage
- Jacket:** KS-PUR
- Jacket color:** black

**Technical Data**

- Temperature range:** – 30 to + 90 °C (46505) – 5 to + 80 °C (46090)
- Minimum bend radius moved\*:** KR min ≥ 7.5 x Ø
- Voltage:** acc. to VDE 42 V; acc. to UL/CSA 80 °C 30 V (46505) 300/300 V UL/CSA 80 °C 300 V (46090)
- Approvals:** UL, CSA, based on VDE  
\* smaller bend radii are possible in many cases – contact us about options



Core number x nominal cross-section in mm <sup>2</sup>	Part no.	Outer diam. max. in mm	Weight kg/m	Cu index kg/m
(4 x 2 x 0.14 <sup>2</sup> + 2 x 0.5 <sup>2</sup> )	46505*	8.4	0.095	0.056
(5 x 2 x 0.14 <sup>2</sup> + 2 x 0.5 <sup>2</sup> )	46090**	9.0	0.105	0.058

\* for Heidenhain system \*\* for Baumüller system

**LIFE-LINE system cables**

- oil-resistant
- UV-resistant
- CFC-free
- flame-retardant
- silicone-free
- RoHS-compliant

LIFE-LINE Safety Cables

**LIFE-LINE system cables.**

**Continuous bending highly-flexible PUR power cable.**



Similar to the illustration.



**HIGHLIGHT**

Co-extruded ICC color coding system based on the DESINA color code

**HIGHLIGHT**

Valley-sealed filling pressure-extruded inner jacket

**HIGHLIGHT**

Cores stranded in very short pitches

**Cable design**

- Conductor:** extra-fine wire conductor made from bare copper wires, design-optimized for maximum flexural strength
- Core insulation:** KS-TPM
- Core identification:** according to INDRAMAT specification
- Core stranding:** cores stranded type-optimized in short pitches with low torsion
- Shielding:** 85 % coverage
- Jacket:** KS-PUR
- Jacket color:** black with ICC color coding based on DESINA color code
- Inner jacket:** KS-PUR

**Technical Data**

- Temperature range:** – 30 to + 90 °C
- Minimum bend radius moved\*:** KR min ≥ 7.5 x Ø
- Voltage:** acc. to VDE 300/500 V (power cores) 300/300 V (control cores), acc. to UL/CSA 80 °C 600 V (power and control cores)
- Approvals:** UL, CSA, based on VDE  
\* smaller bend radii are possible in many cases – contact us about options



Core number x nominal cross-section in mm <sup>2</sup>	Part no.	Outer diam. max. in mm	Weight kg/m	Cu index kg/m
(4 x 2.5 <sup>2</sup> + 2 x (2 x 1 <sup>2</sup> ))	46315 IM*	16.9	0.405	0.256

\* for INDRAMAT INK 0602 system

**LIFE-LINE system cables**

- oil-resistant
- UV-resistant
- CFC-free
- halogen-free
- flame-retardant
- silicone-free
- RoHS-compliant

# LIFE-LINE Safety Cables

## LIFE-LINE DATA 200 C.

### Continuous bending highly-flexible PVC data cable.



Similar to the illustration.



#### HIGHLIGHT

Co-extruded ICC color coding system based on the DESINA color code

#### HIGHLIGHT

Optimized construction for quick and precise stripping

#### HIGHLIGHT

Cores stranded in very short pitches

#### Cable design

- Conductor:** extra-fine wire conductor made from bare copper wires, design-optimized for maximum flexural strength
- Core insulation:** KS-PVC
- Core identification:** acc. to DIN 47100
- Core stranding:** stranded in layers stranded in short pitches with low torsion
- Shielding:** 85 % coverage
- Jacket:** KS-PVC
- Jacket color:** black with ICC color coding based on DESINA color code

#### Technical Data

- Temperature range:** – 5 to + 80 °C
  - Minimum bend radius moved\*:** KR min  $\geq 7.5 \times \varnothing$
  - Voltage:** acc. to VDE 300/300 V  
acc. to UL 80 °C 300 V
  - Approvals:** UL, based on VDE
- \* smaller bend radii are possible in many cases – contact us about options



#### LIFE-LINE DATA 200 C

Core number x nominal cross-section in mm <sup>2</sup>	Part no.	Outer diam. max. in mm	Weight kg/m	Cu index kg/m
(10 x 0.25 <sup>2</sup> )	47329	7.4	0.076	0.046

- oil-resistant
- UV-resistant
- CFC-free
- flame-retardant
- silicone-free
- RoHS-compliant

LIFE-LINE Safety Cables

## LIFE-LINE DATA 200 C / 400 C – Twisted Pairs.

### Continuous bending highly-flexible PVC data cables.



Similar to the illustration.



#### HIGHLIGHT

Co-extruded ICC color coding system based on the DESINA color code

#### HIGHLIGHT

Extremely abrasion-resistant, UV-resistant outer jacket

#### HIGHLIGHT

Cores stranded as twisted pairs in short pitches

#### Cable design

- Conductor:** extra-fine wire conductor made from bare copper wires, design-optimized for maximum flexural strength
- Core insulation:** KS-PVC
- Core identification:** acc. to DIN 47100
- Core stranding:** twisted pairs, cores stranded type-optimized in short pitches with low torsion
- Shielding:** 85 % coverage
- Jacket:** KS-PVC
- Jacket color:** black with ICC color coding based on DESINA color code
- Inner jacket:** KS-PVC (45167)

#### Technical Data

- Temperature range:** – 5 to + 80 °C
  - Minimum bend radius moved\*:** KR min  $\geq 7.5 \times \varnothing$
  - Voltage:** acc. to VDE 300/300 V  
acc. to UL 80 °C 300 V
  - Approvals:** UL, CSA, based on VDE
- \* smaller bend radii are possible in many cases – contact us about options



#### LIFE-LINE DATA 200 C / 400 C – TP

Core number x nominal cross-section in mm <sup>2</sup>	Part no.	Outer diam. max. in mm	Weight kg/m	Cu index kg/m
(1 x 2 x 0.25 <sup>2</sup> )	45167*	5.3	0.035	0.015
(4 x 2 x 0.5 <sup>2</sup> )	47637**	9.0	0.110	0.070

- oil-resistant
- UV-resistant
- CFC-free
- flame-retardant
- silicone-free
- RoHS-compliant

\* with inner jacket \*\* without inner jacket

Even easier to order.

# Pre-assembled cables connection compatible on the INDRAMAT standard.

Do you need ready-to-connect, pre-assembled **signal and power cables** for drive systems, connection compatible to the INDRAMAT specification? Simply order by quoting just the **order number and cable length**, and wait for your original LIFE-LINE quality goods to arrive.

**Properties of the LIFE-LINE cables:**

- UV-resistant
- CFC-free
- flame-retardant
- Approvals: UL, CSA\*, based on VDE, RoHS-compliant



\* not for: IKB 0048, IKB 0049

**Pre-assembled cables**

- easy to order with just order number and cable length
- according to INDRAMAT specifications
- just-in-time delivery with three working days
- no minimum order quantities
- individual cable lengths without surcharge
- checked and monitored for reliable connection
- RoHS-compliant

## Power cables

Similar to the illustration.

KS alternative to INDRAMAT standard	Order No.:	Diameter mm	Minimum bend radius moved KR <sub>min</sub>
IKG 4139	610800	16.0	7.5 x Ø
IKG 4118	610805	19.0	7.5 x Ø

LIFE-LINE cables for cable carriers **ICC** KABELSCHLEPP Integrated Colour Code

## Encoder cable

Similar to the illustration.

KS alternative to INDRAMAT standard	Order No.:	Diameter mm	Minimum bend radius moved KR <sub>min</sub>
IKS 4001	610810	10.3	7.5 x Ø

LIFE-LINE cables for cable carriers **ICC** KABELSCHLEPP Integrated Colour Code

## BUS cables

Similar to the illustration.

KS alternative to INDRAMAT standard	Order No.:	Diameter mm	Minimum bend radius moved KR <sub>min</sub>
IKB 0048	610815	9.9	15 x Ø
IKB 0049	610820	9.9	15 x Ø

LIFE-LINE cables for cable carriers

# WAVE-BELT Conveyor

Innovative conveyors.

## Intelligent design for fast service – new module connections.

The modular concept of our proven WAVE-BELT conveyor is impressive for its significant increase in service life and its drastic reduction in servicing times.

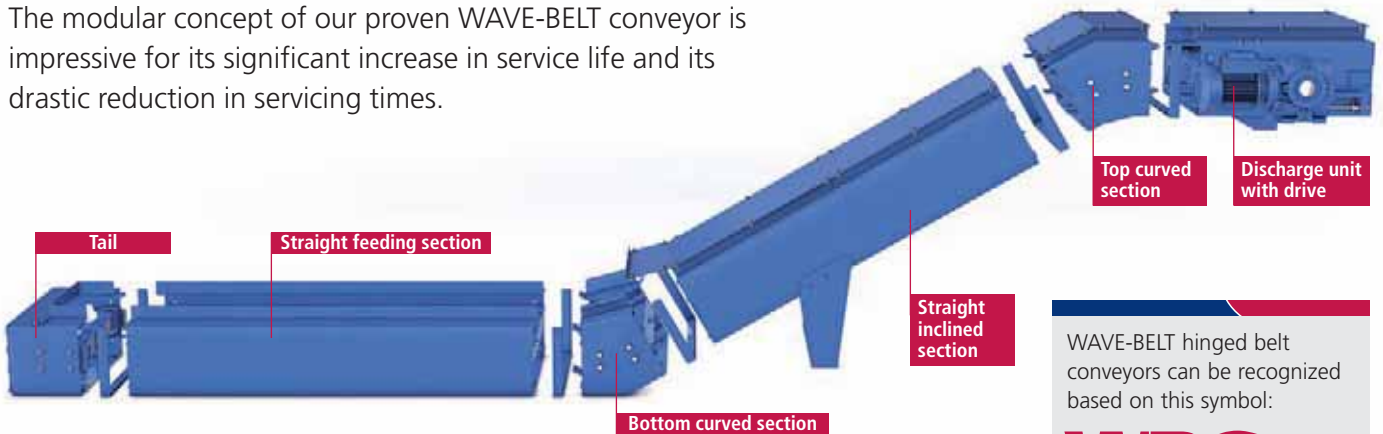

WAVE-BELT Conveyor

### New internal module connection.

The individual modules are screwed together at the new flange connection. For repairs or service work the module connection can be released and re-established easily.

WAVE-BELT hinged belt conveyors can be recognized based on this symbol:



■ Covered, internal module coupling.

### New module connection

- extremely robust thanks to multiple threaded joints
- short maintenance and repair times thanks to quick and easy separation and connection of individual modules
- optimized overlapping with minimized lateral structure



■ Optimized overlapping with minimized lateral structure.



■ Extremely easy to service – quick-release connection.



■ Proven crossbar with sealing rings.



WAVE-BELT hinged belts with optimized axis system.

# Very easy to service thanks to modular axes.

Our proven conveyors have become **even easier to service** thanks to the newly developed module axes of the WAVE-BELT hinged belts.

New axis mounts have been developed for the WAVE-BELT system in which only short modular axes are needed in the area of the side rims.

When the belt plates are removed the **inside of the conveyor housing is freely accessible**. Maintenance and cleaning work can be performed quickly and easily. Any dirt and conveyed material can be removed from the interstices quickly and easily.

The belt plates are bolted as usual onto the side rims and can be easily replaced if needed without having to dismantle the complete conveyor belt. The special form of the plates makes the complete belt extremely flexurally rigid and gives it a high load capacity.

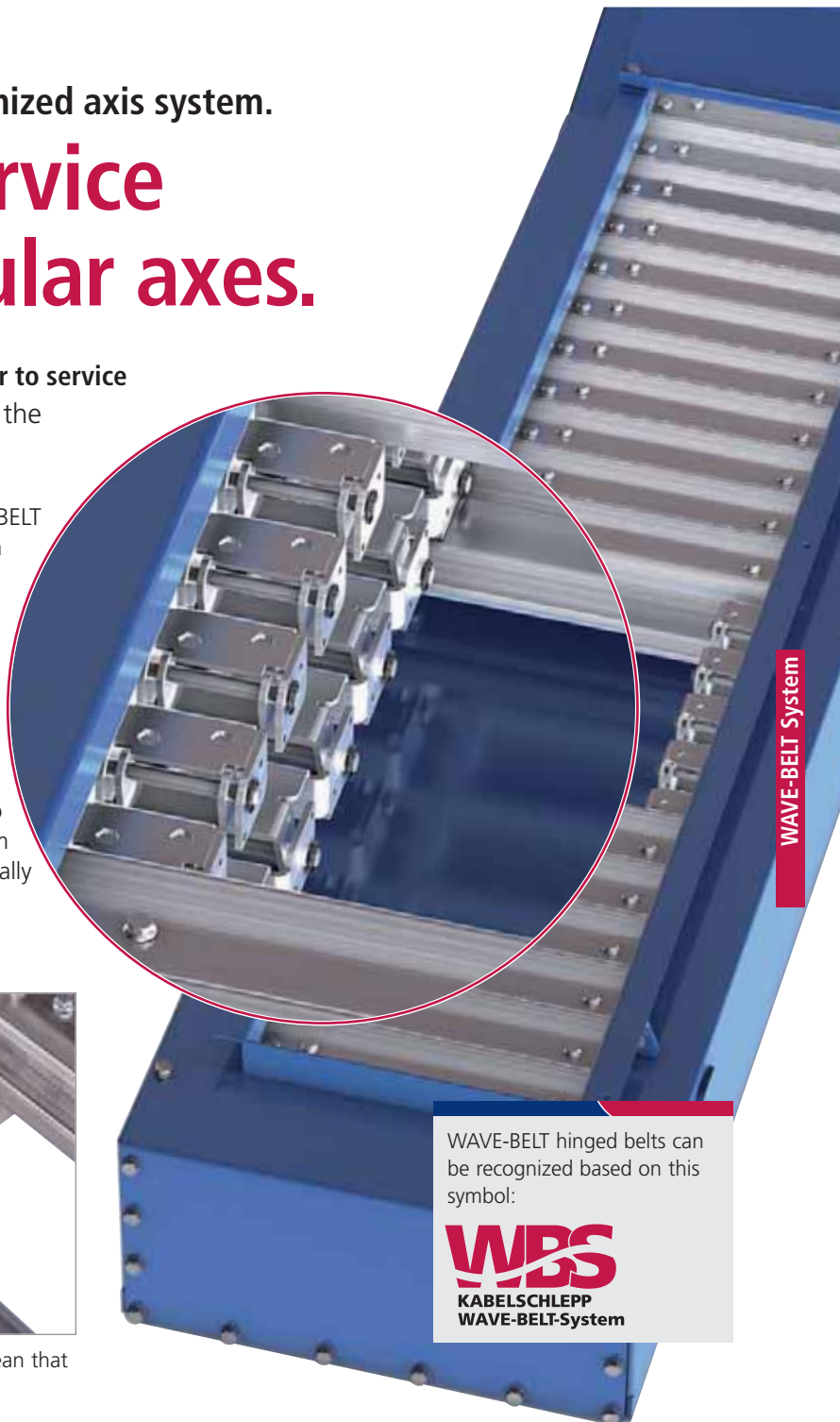

WAVE-BELT hinged belts can be recognized based on this symbol:

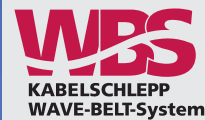

■ Easily removable belt plates and the new modular axis mean that the inside of the conveyor housing is freely accessible.

## Up to 12 % weight savings.

With large hinged belt widths, weight savings of up to 12 % are possible through the use of modular axes.

This makes handling of the hinged belts much easier, for example for maintenance or complete replacement of the hinged belt.



Extremely good gliding characteristics and very high robustness.

## Our state-of-the-art components for telescopic covers.

The wiper systems VA 12 and VA 17 have proven themselves in practice as particularly effective systems. They effectively prevent the penetration of coolants and chips into the inside of the machine. The use of new materials has significantly **improved gliding characteristics and robustness**, especially for dry running.

### New wiper lip material – reduced gliding resistance, longer service life.

The new material of the wiper lips has improved gliding characteristics. The new wipers have the designation "G" for gliding. They can now also be used where little lubricant is generated, e.g. on machine tools.

Wipers



■ Wiper lip  
VA 12 G and VA 17 G.

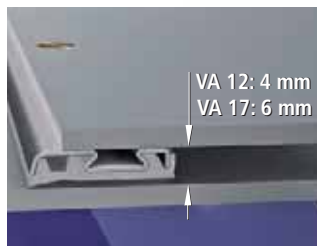

### New metal turn-lock fasteners – stable and heat-resistant.

The wiper systems VA 12 G and VA 17 G are fastened with turn-lock fasteners on the cover plates. This means that the wipers can be replaced without dismantling the telescopic cover. The turn-lock fasteners can be unlocked by turning through 90°, and the wiper can be released. As an option to the previously available turn-lock fasteners of plastic, they are now available made of metal. These provide even more **stable, extremely positive fastening** of the wiper. Hot chips can burn into turn-lock fasteners made of metal. Damage to the slot on the turn-lock fastener is thus excluded.



■ Easy release of the wipers from the cover plates.



■ Metal turn-lock fasteners – stable connection.



■ Resistant to red-hot chips – turn-lock fasteners made of metal.

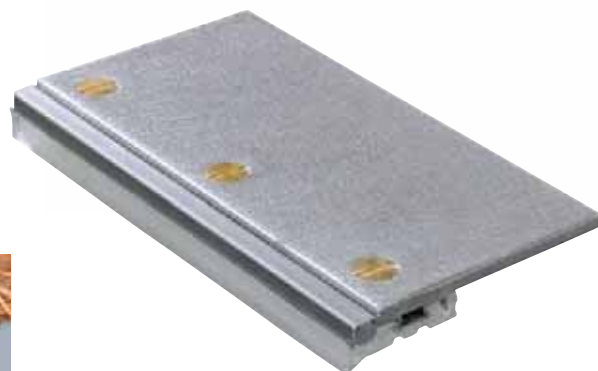

# Progressive damping elements

## Progressive damping elements on telescopic covers – highly efficient impact damper.

During travel of telescopic covers, impact pulses are generated during expansion from driving and braking of the individual covers. This is increased for travel at high speeds. To reduce this effectively we have developed a new damper. This can be used for travel speeds of up to 45 m/min at a max. box weight of 100 kg.



■ Highly efficient impact damper.

### Progressive damping elements

- drastic reduction of impact pulses
- suitable for travel speeds of up to 45 m/min at a max. box weight of 100 kg
- very high absorption characteristics
- easy replacement during maintenance and repair work
- optimized selection of materials

Damping elements



■ Extremely reduced impact pulses thanks to progressive damping.

■ Simple replacement of the damper with plug connection.

# Harness mechanics with sliding bearings

Proven harness mechanics with new bearings.

## Our state-of-the-art components for telescopic covers.

Our proven SXM harness mechanics ensure an impact-free expansion / compression of telescopic covers. This eliminates the impact noise of the boxes.

Force peaks that appear when the boxes strike against each other with covers without harnesses do not occur.

Especially at high travel speeds the material load is reduced significantly, thus **increasing the service life** of the covers.

NEW: sliding bearings



The KABELSCHLEPP harness-technology can be recognized based on this symbol:

**SXM**  
KABELSCHLEPP  
Synchronized Expansion Mechanism

Harnesses with sliding bearings

### Harness mechanics with sliding bearing

- longer service life due to ideal combination of materials
- low system friction
- tolerance-free simultaneous running of all boxes

### Longer service life – moves even easier.

Instead of metal washers, now **sliding bearings of special plastic** with a self-lubricating effect are used. The reduced coefficient of friction means that the harnesses run even more easily – the entire system friction is reduced, and the service life is increased.

The sliding bearings used are designed for dry running, but are also resistant to oil and greased and are extremely suitable for installation in machine tools.

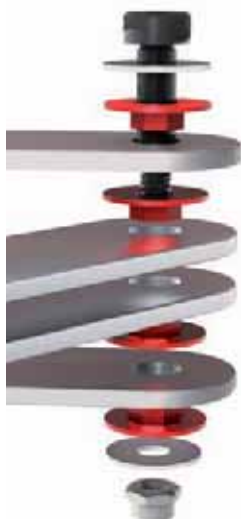

- Maintenance-free harness with sliding bearing of high-performance plastic.



- Hinge elements with sliding bearings on all hinges.

**New standard color for conveyor systems.**

# Fresh colors for a modern machine design.

That our proven conveyor systems, whether hinged belt conveyors, belt conveyors or scraper conveyors can be integrated easily into a large number of production environments with a wide variety of requirements is something that we have demonstrated thousands of times over. And we continue to provide this service.

In addition to sophisticated, reliable technology, modern machine design also includes an attractive design with contemporary colors.

We have defined RAL 7035 (light gray) as the new standard color for our conveyors. Unless otherwise specified, products are delivered in RAL 7035.



New standard color

## Conveyors available in all RAL colors.

To allow optimal visual integration of our conveyor systems into existing machine environments, they are available immediately in all RAL colors.

Simply specify the desired (RAL) color when ordering.

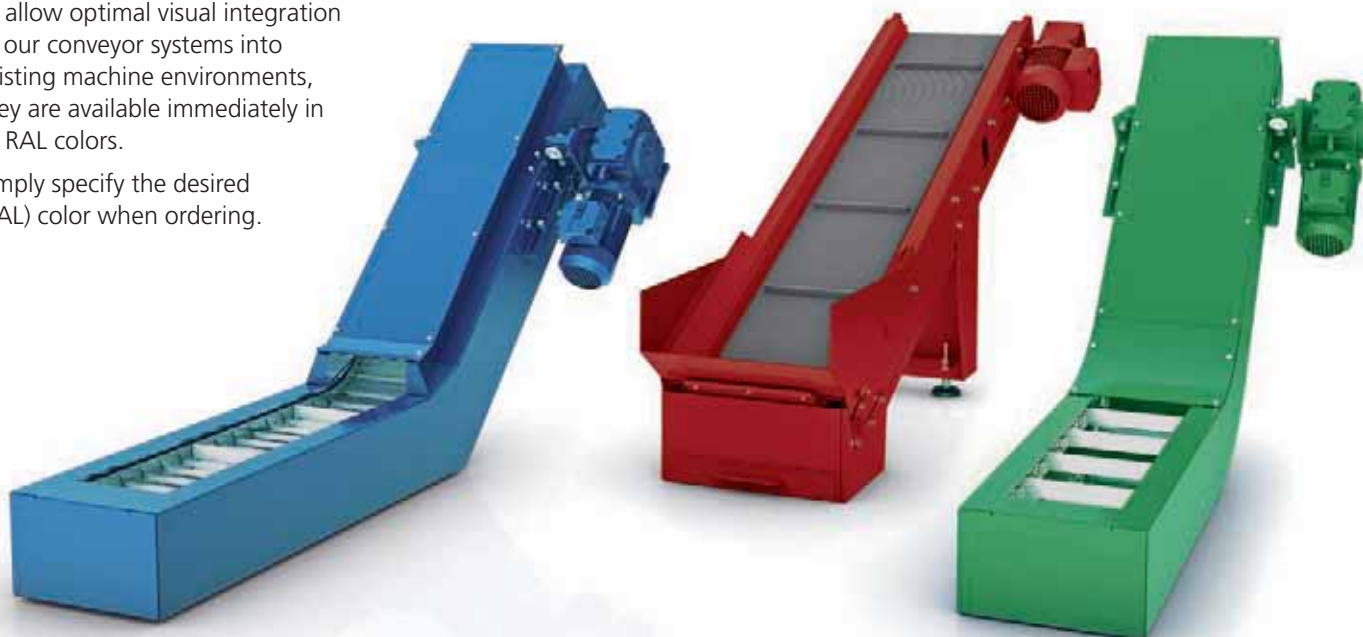

# KABELSCHLEPP is there for you: Around the world.

Sales Network

## Germany

### Headquarter

KABELSCHLEPP GmbH  
Marienborner Str. 75  
D-57074 Siegen  
Fon: +49-271/5801-0  
Fax: +49-271/5801-220  
E-Mail: info@kabelschlepp.de

### Service-Center

KABELSCHLEPP GMBH-HÜNSBORN  
Wielandstraße 1 - Industriegebiet Ost  
D-57482 Wenden-Hünsborn  
Fon: +49-2762/97420  
Fax: +49-2762/974299  
E-Mail: ksh@kabelschlepp.de

### Automotive

KABELTRAX Europe GmbH –  
Automotive  
Marienborner Str. 75  
D-57074 Siegen  
Fon: +49-271/5801-444  
Fax: +49-271/5801-40444  
E-Mail: info@kabeltrax.de  
Web: kabeltrax.de

## KABELSCHLEPP International

### America

KABELSCHLEPP AMERICA  
7100 West Marcia Road  
Milwaukee, WI 53223-3363  
Fon: +1414354 1994  
Fax: +1414354 1900  
E-mail: info@kabelschlepp.com  
Web: kabelschlepp.com

KABELTRAX LLC – Automotive  
7100 West Marcia Road  
Milwaukee, WI 53223-3363  
Fon: +1414354 1994  
Fax: +1414354 1900  
E-mail: info@kabeltrax.com  
Web: kabeltrax.com

### Argentina

NORTECNICA S.R.L.  
103 Heredia 638  
1672 Villa Lynch - Pica  
Pcia. De Buenos Aires  
Fon: +54-11/47 57 31 29  
Fax: +54-11/47 57 10 88  
E-mail: info@nortecnica.com.ar

### Australia

Wampfler SCA Pty Ltd  
Unit 2/9 Archimedes Place  
Murarrie, Brisbane, QLD 4172  
P.O. Box 3556  
Tingalpa, Brisbane, QLD 4173  
Fon: +61-7/3902-6000  
Fax: +61-7/3902-6001  
E-mail: sales@wampfler.com.au  
Web: wampfler.com.au

### Austria

Robert Ganglberger  
Holzbauernstraße 20  
4050 Traun  
Fon: +43-7229/743 30  
Fax: +43-7229/6 15 03  
E-mail: ganglberger.r@aon.at  
Web: kabelschlepp.at

### Belgium

Wisman Techniek BVBA  
Drie Eikenstraat 112  
2650 Edegem  
Fon: +32-3/4572482  
Fax: +32-3/4572980  
E-mail: electro@wisman-techniek.be  
Web: wisman-techniek.be

### Brazil

Porta Cabos Indústria e Comércio Ltda.  
Av. Dr. Ulysses Guimarães, 3.388  
Bloco B – Vila Lídia  
09990-080 – DIADEMA – SP.  
Fon: +55-11-4 072-2217  
Fax: +55-11-4072-1223  
E-mail: portacabos@portacabos.com.br  
Web: portacabos.com.br

### China

TSUBAKI KABELSCHLEPP SHANGHAI CO.,  
LTD.  
Rm. 701, Tomson Financial Building,  
No. 710 Dong Fang Rd.,  
Pudong Shanghai, P.R.C. 200122  
Fon: +86-21/6867 05 11  
Fax: +86-21/68 76 94 56  
E-mail: zhangtks@sh163.net

### Croatia

INOSIS ITEM d.o.o.  
Susedsko polje bb  
10090 Zagreb  
Fon: 00385-1-345 75 77  
Fax: 00385-1-345 75 78  
E-mail: inosis.item@gmx.net

### Czech Republic

OPTICONTROL s.r.o.  
Lelekovice 103  
66431 Brno  
Fon: +420-5/4123 2288  
Fax: +420-5/41 23 27 11  
E-mail: info@opticontrol.cz  
Web: kabelschlepp.cz

### Denmark

Bagger-Nielsen  
Svalehøjvej 10  
3650 Ølstykke  
Fon: +45-7020/7633  
Fax: +45-7020/7603  
E-mail: info@bagger-nielsen.dk  
Web: bagger-nielsen.dk

### Finland

Movetec Oy  
Hannuksentie 1  
02270 Espoo  
Fon: +358-9/5259230  
Fax: +358-9/52592333  
E-mail: info@movetec.fi  
Web: movetec.fi

### France

KABELSCHLEPP FRANCE S.A.R.L.  
27, Rue du chemin vert  
B.P. 1 Bâtiment Pariwest  
78612 Le Perray en Yvelines  
Fon: +33-1/348463 65  
Fax: +33-1/348486 71  
E-mail: contact@kabelschlepp.fr  
Web: kabelschlepp.fr

### Great Britain

METOOOL PRODUCTS LTD.  
Lilac Grove, Beeston  
Nottingham NG9 1PG  
Fon: +44-115/9225931  
Fax: +44-115/9224578  
E-mail: postmaster@metool.com  
Web: metool.com

### Greece

E. D. Koumakis S.A.  
O.T. 32 Sindos Industrial Area  
P.O.B. 199  
57022 Thessaloniki - Hellas  
Fon: +30-2310/796791  
Fax: +30-2310/795056  
E-mail: info@koumakis.gr  
Web: koumakis.gr

### Hungary

FIGRA - Műszaki Kereskedelmi Kft  
Szentmiklósi út 14.  
1213 Budapest  
Fon: +36-1/420-3053  
Tel./Fax: +36-1/277-6067  
E-mail: figra@t-online.hu  
Web: figra.hu

### India

Kabelschlepp India Pvt. Ltd.  
B-14, ITI Ancillary Industrial Estate  
Mahadevapura Post,  
Bangalore - 560048  
Fon: +91-80-41 15 89 97  
Fax: +91-80-41 15 89 98  
E-mail: sales@kabelschlepp.info

### Israel

RS Tech Ltd  
64 Ashkenazy St.  
Tel-Aviv 69869  
Fon: +972-3-649 0454  
Fax: +972-3-648 7307  
E-mail: samitai@012.net.il



**Italia**

KABELSCHLEPP ITALIA S.R.L.  
Via Massari Marzoli, 9  
21052 Busto Arsizio - VA  
Fon: +39-0331/350962  
Fax: +39-0331/341996  
E-mail: infoksi@kabelschlepp.it  
Web: kabelschlepp.it

**Japan**

TSUBAKIMOTO CHAIN COMPANY  
1-3, Kannabidai 1 Cho-me  
Kyotanabe  
Kyoto 610-0380  
Fon: +81-774-64-5212  
Fax: +81-774-64-5024  
E-mail:  
takayuki.matsuda@gr.tsubakimoto.co.jp  
Web: tsubakimoto.co.jp

**Korea**

KABELSCHLEPP Korea Inc.  
203-4, Misa-dong, Hanam-shi,  
Kyunggido, 465-140  
Fon: +82-31-792-5860  
Fax: +82-31-792-5861  
E-mail: sale@kskorea.kr

**Liechtenstein**

see Switzerland

**Luxembourg**

Wisman Techniek BVBA  
Drie Eikenstraat 112  
2650 Edegem  
Fon: +32-3/4572482  
Fax: +32-3/4572980  
E-mail: electro@wisman-techniek.be  
Web: wisman-techniek.be

**Netherlands**

Wisman Electrotechniek  
Postbus 36  
7260 AA RUURLO  
Fon: +31-88/0023500  
Fax: +31-88/0023599  
E-mail: electro@wisman-techniek.nl  
Web: wisman-techniek.nl

**Norway**

Ing. H. Asmyhr a.s.  
Hvamsvingen 10  
2013 Skjetten  
Fon: +47-64/834550  
Fax: +47-64/834555  
E-mail: firmapost@asmyhr.no  
Web: asmyhr.no

**Poland**

KABELSCHLEPP Sp z o.o. Polen  
ul. Piekna 13  
85303 Bydgoszcz  
Fon: +48-52/3487711  
Fax: +48-52/3487715  
E-mail:  
kabelschlepp@kabelschlepp.com.pl  
Web: kabelschlepp.com.pl

**Portugal**

Vahle Portuguesa  
Sistemas de Alimentação  
Eléctrica, Lda.  
Quinta do Borel,  
Rua Tenente Gouveia, 21-21<sup>A</sup>  
2720-525 Amadora  
Fon: +351 214998690  
Fax: +351 214998699  
E-mail: geral@vahle.pt  
Web: vahle.pt

**Russia**

see White Russia

**Singapore**

KABELSCHLEPP Singapore Pte. Ltd.  
60 Kaki Bukit Place  
#07-15 Eunos Techpark  
Singapore 415979  
Fon: +65-68419008  
Fax: +65-68416887  
E-mail: a.seah@kabelschlepp.com.sg

**Slovakia**

KABELSCHLEPP SYSTEMTECHNIK  
spol. s r.o.  
Povazská 67  
94067 Nové Zámky  
Fon: +421-35/6923200  
Fax: +421-35/6923222  
E-mail: info@kabelschlepp.sk  
Web: kabelschlepp.sk

**Slovenia**

Inoteh d.o.o.  
K Železnici 77  
2345 Bistrica ob Dravi / Slovenia  
Fon: +386-2/6651131  
Fax: +386-2/6652081  
E-mail: info@inoteh.si  
Web: inoteh.si

**South Africa**

MAGQUIP PTY LTD  
P.O.Box 682  
Maraisburg 1700  
Fon: +27-11/4748933/39  
Fax: +27-11/4748940  
E-mail: info@magquip.co.za

**Spain**

Exclusivas Rein, S.A.  
Portal de Gamarra, 36  
Pabellón 14  
01013 Vitoria  
Fon: +34-945/262922  
Fax: +34-945/266437  
E-mail: tecnico@exrein.es  
Web: exrein.es

**Sweden**

Stiebel AB  
Dalhemsvägen 35  
14146 Huddinge  
Fon: +46-8/7119939  
Fax: +46-8/7119923  
E-mail: info@stiebel.se  
Web: stiebel.se

**Switzerland/Liechtenstein**

Hans Hess + Co. AG  
Gewerbestrasse 16/Postfach  
8800 Thalwil  
Fon: +41-44/7225500  
Fax: +41-44/7225502  
E-mail: mail@hanshess.ch  
Web: hanshess.ch

**Taiwan**

SIGNET TRADING CO. LTD.  
No. 99, An-Chai 8th St.  
Hsin-Chu Industrial Park.  
Hu-Ko, Hsin-Chu  
Fon: +886-35/978808  
Fax: +886-35/978848  
E-mail: gudel@ms42.hinet.net  
signet@tpts4.seed.net.tw

**Thailand**

PLANET T & S CO., LTD  
42 Seree 4 Road, Suanluang  
Suanluang, Bangkok  
Fon: +6627189935-7  
Fax: +6627203343  
E-mail: info@planet.co.th  
Web: planet.co.th

**Turkey**

Kabellimited  
Kabel Enerji iletim zincirleri  
San. Tic. Ltd. Sti.  
Nilüfer Ticaret merkezi 61. Sk. No: 17  
16120 Nilüfer-Bursa  
Fon: +90-224/4440075  
Fax: +90-224/4417230  
E-mail: kabel@kabeltr.com  
Web: kabeltr.com

**Ukraine**

see White Russia

**Venezuela**

NORSTAT C.A.  
Apdo. 68761  
Caracas 1062 A  
Fon: +58/212425358  
Fax: +58/212416848

**White Russia/Russia**

Asboga LTD  
Minsk region  
Smolevichski ar. Vill. Zadomya 41a  
222210 Minsk / Belarus  
Fon: +375-17285-64-67  
+375-17280-2486  
Fax: +375-17287-3727  
E-mail: ks@asboga.ru





### Cable and Hose Carrier Systems

- Cable carriers made of Steel and Plastic
- QUANTUM Cable and hose carrier system
- PROTUM Cable and hose carrier system
- PROFILE Cable and hose carrier system
- ROBOTRAX Cable and hose carrier system
- LIFE-LINE Cable systems
- TOTALTRAX Turn-Key Systems

### Guideway Protection Systems

- Telescopic covers
- Link apron covers
- Way wipers
- Conical spring covers
- Bellows

### Conveyor Systems

- Hinged belt conveyors
- Scraper conveyors
- Belt conveyors

**KABELSCHLEPP GmbH**  
Marienborner Str. 75  
D-57074 Siegen  
Fon: +49 271 5801-0  
Fax: +49 271 5801-220  
E-Mail: [info@kabelschlepp.de](mailto:info@kabelschlepp.de)  
[kabelschlepp.de](http://kabelschlepp.de)

**KABELSCHLEPP worldwide**  
For contacts, addresses  
and much more, visit our  
web site at [kabelschlepp.de](http://kabelschlepp.de)