

Interlock Control System e.g. for Clean Rooms or Laboratories

Quite often one of the requirements of clean room technology or laboratories is, that certain doors may only be opened if others are closed. The DICTATOR interlock control system is **the ideal solution to link up to 10 doors or up to 10 groups of doors** (each with 10 doors maximum). The dependencies between different doors are programmed directly in the control modules on each door with DIP-switches, using a **very easy, adjustable matrix control system**. The dependencies between the doors can **also be changed on site at any time**, not requiring any special programming know-how.

The interlock control terminal disposes of a **potential-free contact** permitting e.g. to pass on the information of each door to a central control system.

The DICTATOR interlock control system is a **modular system** and therefore extremely **flexible**. All components are provided with a plug-in connection, which considerably reduces installation costs. The system also provides a tested and approved terminal for **emergency exit** doors (according to German standard). The system is also available in an **explosion-proof** execution.

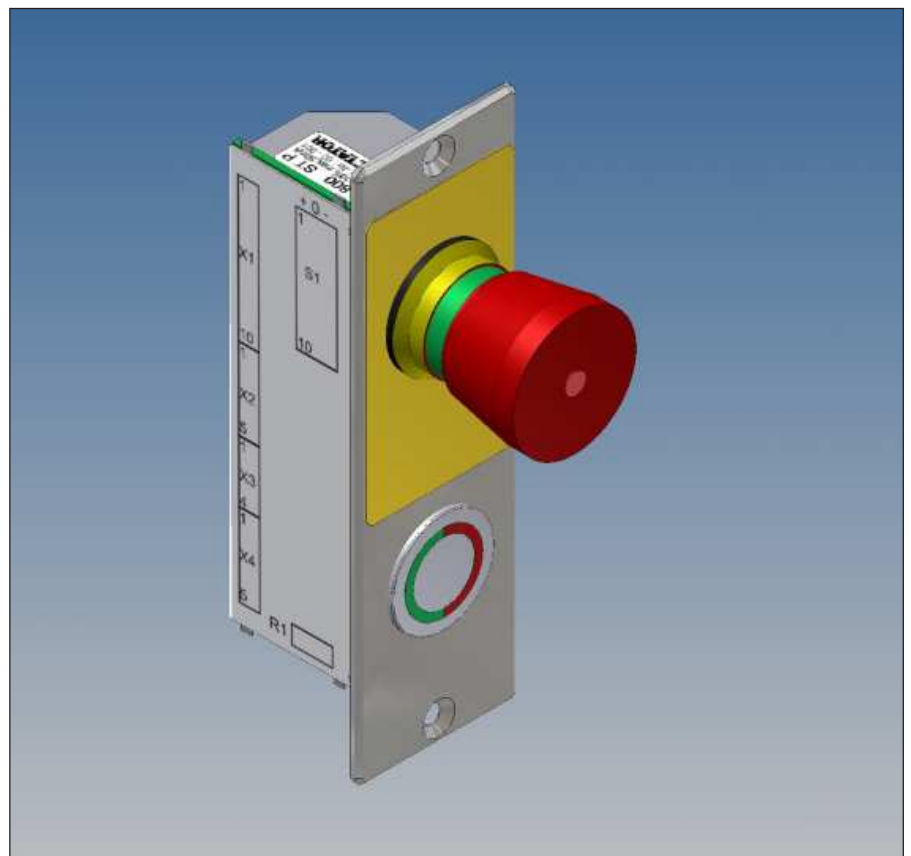

Components

Interlock control terminal with push button, illuminated ring and emergency-open switch

Operating terminals (for the opposite side of the door, supplementing the control terminal)

Terminal for emergency exits

Plug-in connection cables

Distribution box

Locking units: bar magnets with feed-back contact

230 VAC/24 VDC power pack, stabilised, 2.7 A or 5 A or

Power pack with battery back-up

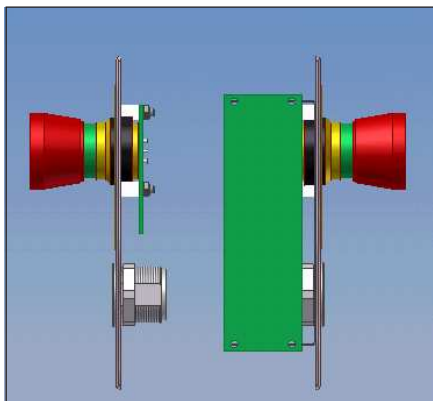

Interlock Control System - System

The interlock control system is designed for a **maximum of 10 doors or 10 groups with each 10 doors at most**. A very simply to adjust matrix control permits to determine the link between the different doors on site. And also to change the links and dependencies later on.

If the interlock unit consists of less than 10 doors/groups, the remaining DIP-switches are just not used. These units can however be enlarged later on to the maximum of 10 doors/groups without having to change the interlock control terminals on the existing doors.

Functioning

The dependencies between the different doors of the unit are set with 10 DIP-switches per door. For details of the adjustment and an example please see page 08.018.00.

A potentiometer permits to adjust on each door a time during which it remains unlocked after the push button has been pressed (0 - 30 sec). This determines the time within which the door has to be opened after having pressed the push button of the terminal. When this time has elapsed the door will be locked again. It is of no significance whether the door has really been opened or not. The period of time to adjust depends amongst others e.g. on the use of the door: interlock systems for material or persons.

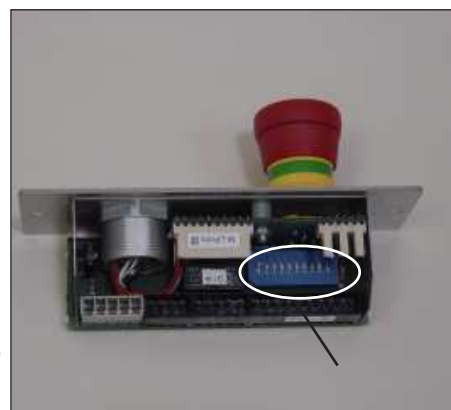

Indication of the Door Status

The **indication of the door status** (unlocked or locked) is realised by an illuminated ring around the push button.

- Green illumination: Door is locked but can be opened using the push button of the terminal
- Red illumination: door is locked. It cannot be opened as it is blocked by another opened door. The illumination of the ring will return to green as soon as the other door(s) is (are) closed again.

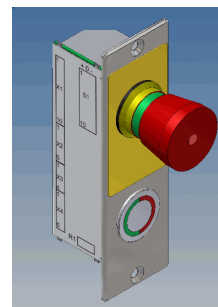

Emergency-Open Switch

Part of the terminals are equipped with an additional **emergency-open switch**. In case of an emergency the door can be unlocked with help of the Emergency-Open switch even while being locked by the interlock control system. The switch remains locked after having been pressed. In order to reactivate the interlock control system the emergency-open switch has to be unlocked by turning. After a short delay the system is ready to work again.

There are two different emergency-open functions possible:

- **Local emergency open (LNA)**: only the door of the respective terminal will be unlocked.
- **Global emergency open (GNA)**: it unlocks all doors of the interlock system.

The function is determined by the wiring of the terminals. Therefore the required function of the emergency-open switch has to be taken into account when deciding on the connection cables (see page 08.016.00).

IMPORTANT: The emergency-open switch of the terminals can only switch 24 VDC. If the emergency-open switch should switch off e.g. a 230 VAC door operator a separate switch is required.

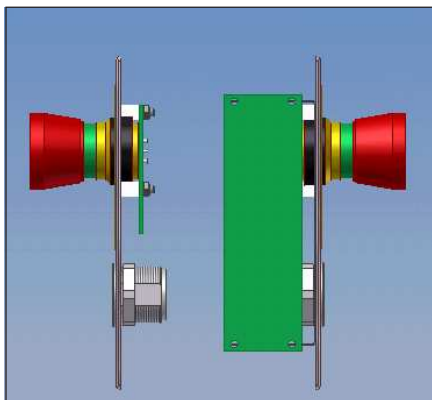

Interlock Control System - Components

The main characteristic of the DICTATOR interlock control system is its lack of a central and complex control system. It splits up the functions to small control modules on each door. This reduces considerably the wiring of the whole installation, even more so as all components are prepared for a plug-in-connection.

Components

Interlock control terminals with push button and (if necessary) Emergency-Open Switch

For each door one interlock control terminal is required. There the dependencies with the other doors of the interlock system are adjusted with DIP-switches on the circuit board. Furthermore there is the potentiometer to determine the duration of unlocking (0 - 30 sec.) and the potential-free make/break contact.

The control circuit board is fixed as a kind of back pack to the front plate of the control terminal. The connection cables are simply plugged in.

Operating terminals

Normally an additional operating terminal is required for the opposite side of the door. This consists either just of the push button or the push button and the Emergency-Open switch.

Emergency exit terminal

The emergency exit terminal has to be used on emergency exit doors in combination with a control terminal without Emergency-Open switch. It has been tested and is approved according to the German standard for emergency exits.

Connection cables

The connection of the terminals and the locking units is done with prefabricated cables with connector. They are available in different lengths.

Distribution box

Per door one distribution box is being required. There is a plug-in connection provided for the cables (24 VDC supply and trip line) to the control terminal. For the wiring between the distribution boxes normal binders are provided.

Central power pack

The 24 VDC power supply of the terminals and the locking units is assured by a central power pack. It is available either with a 2.7 A or 5 A power supply, depending on the components used in the interlock unit and their power consumption.

Locking element

The doors of the interlock unit should be locked with the DICTATOR bar magnets.

Special functions

- Time control unit

DICTATOR provides a special time control unit in order to adjust lock times for each single interlock door (e.g. in case of decontamination interlocks).

- Additional relay controlled functions

It is possible to provide sockets for plug-in relays in the distribution boxes in order to realise special functions.

- Interface

An interface permits the connection of the interlock system to a facility management system. This permits to channel the information on the doors (closed, locked, unlocked) to a central system and to forward signals vice versa. The communication software has to be provided by the customer.

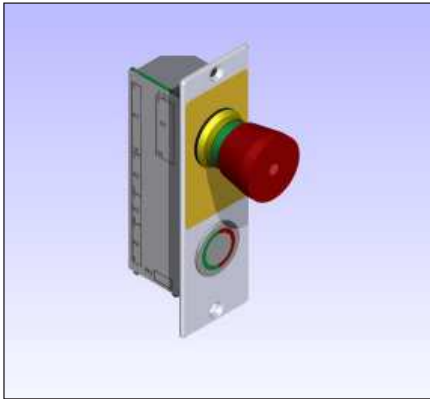

Interlock Control System - Control Terminals

The control terminal is the **central component** of the DICTATOR interlock control system, being the component with the control circuit board on which the dependencies between the different doors are set.

There are **different models** of the control terminal available:
 - with and without an Emergency-Open switch
 - for installation in hollow profiles or for universal installation

The DICTATOR terminals meet the requirements of cleanroom technology. As push button a special piezo-type key is used that reacts on very little pressure. The push button is surrounded by an illuminated ring, one half red, the other half green. Both front plate and push button are made of stainless steel.

Types

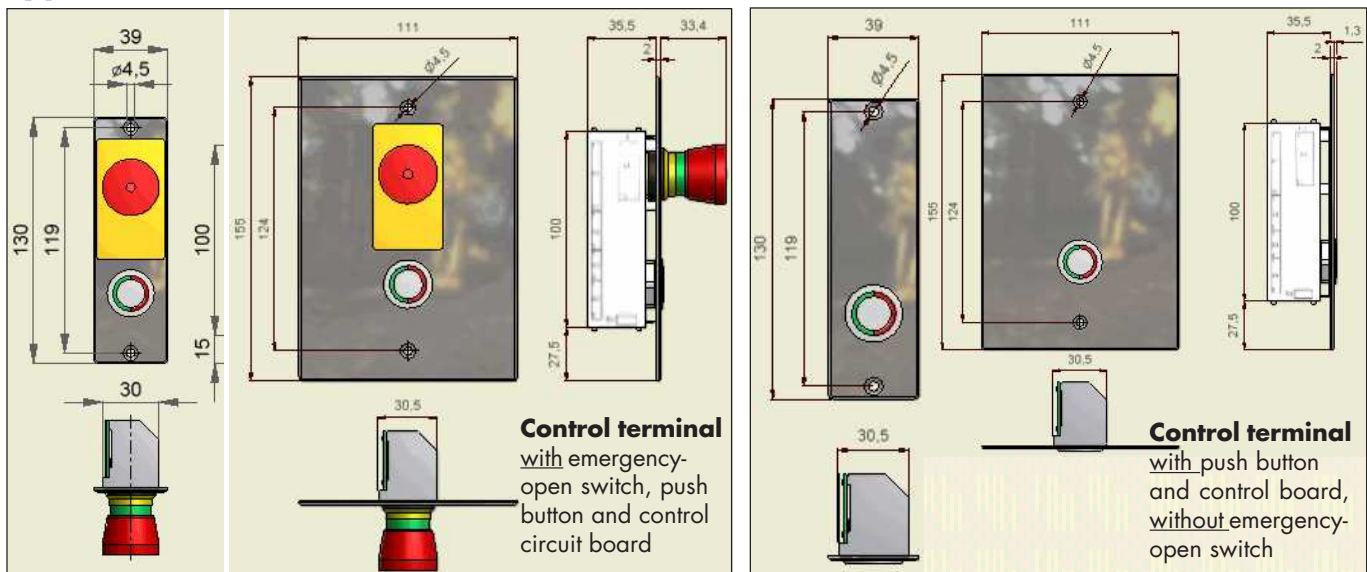

1) Control terminals for hollow profiles "P" (narrow front plate)

- **Control terminal ST P, part no. 710800**
Description: Control terminal with emergency-open switch and push button
- **Control terminal ST oN P, part no. 710802**
Description: Control terminal with push button, without emergency-open switch

2) Control terminals for universal installation "U" (wide front plate)

- **Control terminal ST U, part no. 710825**
Description: Control terminal with emergency-open switch and push button
- **Control terminal ST oN U, part no. 710827**
Description: Control terminal with push button, without emergency-open switch

All control terminals are provided with a potential-free contact in order to pass on the information on the status of the door (open/locked) to a facility control system.

Technical Data

Power consumption	24 VDC +/- 15 %
<u>with</u> emergency-open switch	50 mA
<u>without</u> emergency-open switch	40 mA
IP rating	IP 20 (push button IP 65)
Capacity of the potential-free contact	make/break, max. 1.5 A at 60 VAC/D
Operating temperature	-10 °C to +40 °C
Push button	Piezo type with red/green illumination
Capacity of the emergency-open switch	1 contact NO: 1.5 A; 1 contact NC: 2.8 A
Emergency-open switch	push-to-lock switch

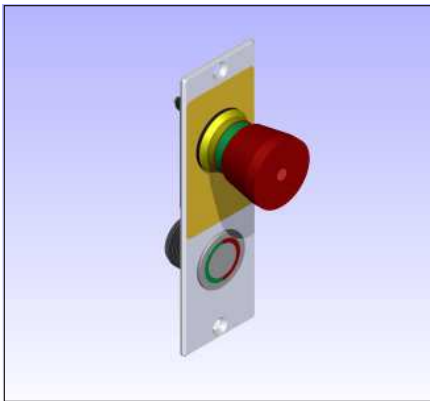

Interlock Control System - Operating Terminals

Normally the doors of an interlock system are operated from both sides. Therefore an additional operating terminal (without control board) connected to the control terminal is required on the other side of the door. The operating terminal is connected to the control terminal quite easily with a plug-in cable. This is available in 2 lengths: 250 mm and 1000 mm. The connection cable must be ordered separately.

Types

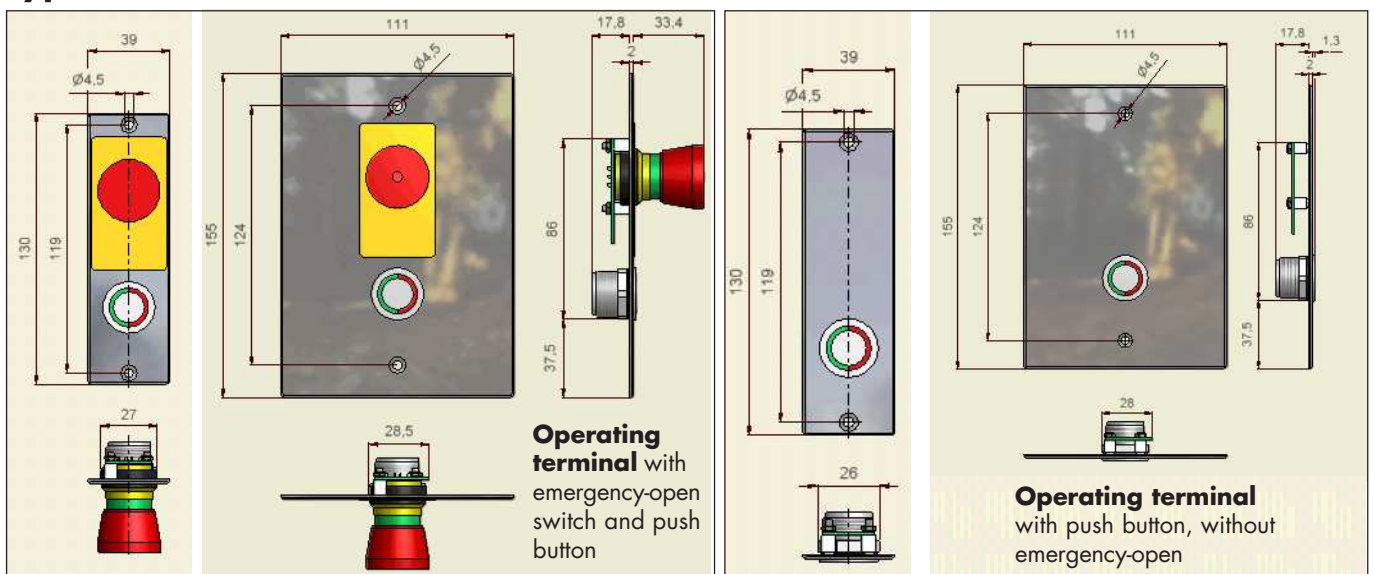

1) Operating terminals for hollow profiles "P" (narrow front plate)

- Operating terminal BT P, part no. 710801

Description: Operating terminal with emergency-open switch and push button

- Operating terminal BT oN P, part no. 710803

Description: Operating terminal with push button, without emergency-open

2) Operating terminals for universal installation "U" (wide front plate)

- Operating terminal BT U, part no. 710826

Description: Operating terminal with emergency-open switch and push button

- Operating terminal BT oN U, part no. 710828

Description: Operating terminal with push button, without emergency-open

Technical Data

Power consumption with emergency open	24 VDC, 30 mA
without emergency open	24 VDC, 15 mA
IP rating	IP 20 (push button IP 65)
Operating temperature	-10 °C to +40 °C
Push button	Piezo-type with red/green illumination
Capacity of the emergency-open switch	1 contact NO: 1.5 A; 1 contact NC: 2.8 A
Emergency-open switch	push-to-lock switch

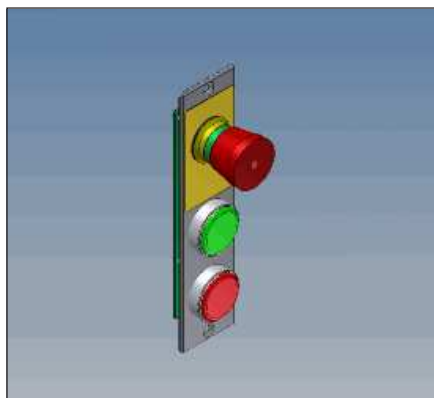

Interlock Control System - Emergency Exit Terminal

The DICTATOR interlock control system provides a terminal designed especially for doors in emergency exits. These doors are equipped both with the normal control terminal and an additional emergency exit terminal. This terminal only serves for unlocking the door during an emergency. The normal operation of the interlock system is done with the control terminal (without Emergency-Open switch).

The emergency exit terminal has been tested by the German TÜV Thüringen and is approved for the use on emergency exit doors (German standard for electrical locking systems on emergency exits), certificate no. P-3250/08.

Dimensions

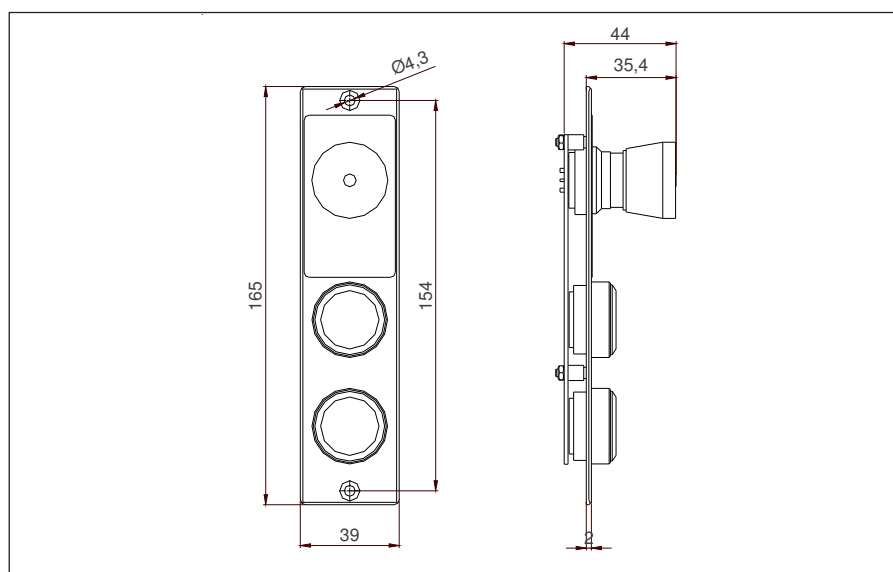

Functioning

The emergency-open switch of the emergency exit terminal permits to unlock the door of the interlock system in case of an emergency. The locking unit has to be an approved DICTATOR bar magnet (starting on page 08.019.00, approved magnets marked with *). The power supply of the bar magnet is interrupted and the door unlocked.

The emergency exit terminal is provided with contacts for external signals (siren, lamp, horn), even supplying a power of up to 1.4 A max. for the signal (ATTENTION: this power consumption has to be taken into account when calculating the required performance of the power pack).

The emergency-open command can also be given directly by a facility management centre.

The door status is indicated by the two lamps on the terminal:

Red LED on: Door is electrically locked.

Red LED off: Door has been opened with the normal control/operating terminal.

Green LED on: Door is released.

After an emergency the door has to be locked again with a separate key (key switch, card reader or similar).

Technical Data

Power consumption	24 VDC, about 80 mA
IP rating	IP 20
Operating temperature	-10 °C to +40 °C
Emergency open contact	2 NC contacts: 2.8 A (current carrying capacity)
Input signal from hazard alert system	NC contact
Output to signals	24 VDC, max. 1.4 A

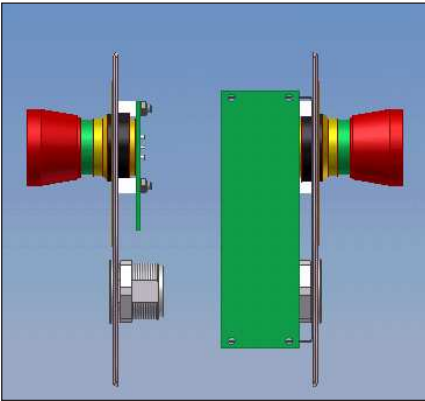

Interlock Control System - Installation Components

The majority of the interlock system components are connected with prefabricated cables with connector. This reduces the installation work and avoids mistakes while connecting the components.

Each door of the interlock system must be equipped just with the required terminals and a locking unit. Further push buttons/switches are not required. This reduction to just a few components also facilitates cleaning in cleanroom areas.

Distribution Box

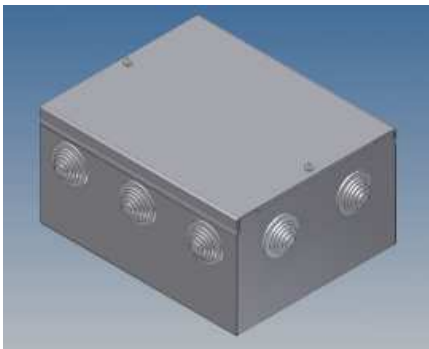

Normally one **distribution box**, part no. 710807, is used per door. There the loop cable (to be provided by the customer) connecting all doors of the interlock system is connected. The quantity of leads of this cable depends on the number of doors within the interlock system. In addition to the 24 VDC power supply (2 leads) one lead (diameter 0.5 mm²) per door is required.

Dimensions:
160 x 86 x 130 mm

If two doors are situated right beside another, a distribution box for 2 doors is available (part no. 710821).

The distribution box can also be furnished with additional relays permitting the realisation of special functions.

The control terminals are connected to the distribution box with the prefabricated connection cables.

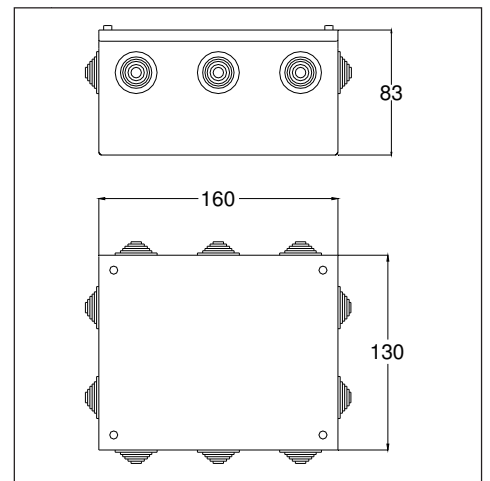

Flush and Surface Boxes

Normally the **terminals** are flush mounted in the frames of the doors.

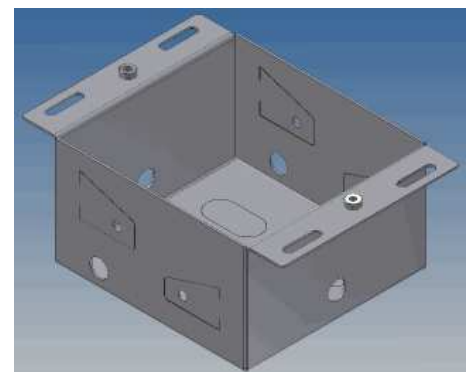
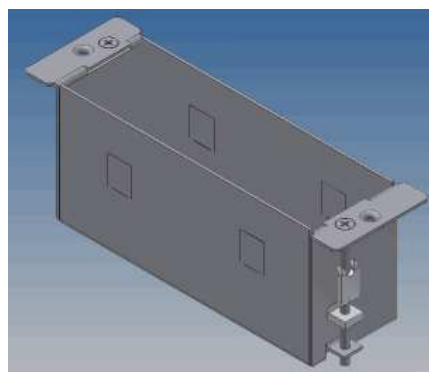

DICTATOR provides flush boxes for both models "P" and "U" (part no. 710829 and 710830). In case a flush mounting is not possible there is a special surface box available for the "P" model. The surface box has IP 65 protection and can be supplied in two different colours:

- white, RAL 9010 (part no. 710831)
- black, RAL 9005 (part no. 710832)

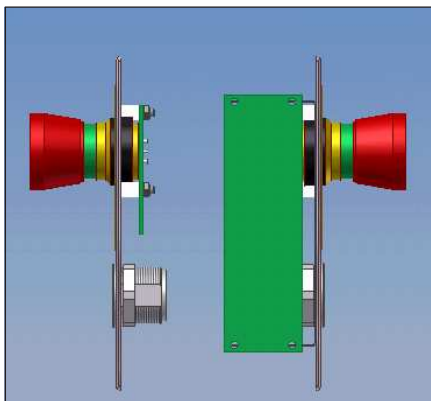

Interlock Control System - Installation Components

Connection Cables



Plug-in connection cable control/operating terminal

The connection cable between control and operating terminal is a plug-in cable with connector on both ends. It is available in two lengths: 250 mm (part no. 710809) and 1000 mm (part no. 710810). It always has to be ordered separately in addition to the control terminal - if the door is equipped with a control and an operating terminal.

In case that a connection cable with a different length is required it can be done on site. However a set of adapters has to be ordered (part no. 710811) as the terminals require a special connector.

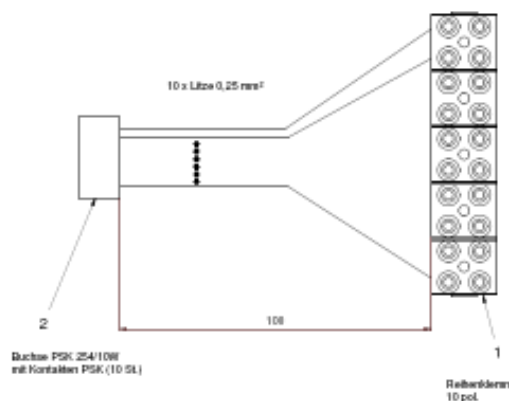

Dummy plug for the control terminal - for stand-alone function

If a door is equipped only with a control terminal without an additional operating terminal on the other side of the door, a dummy plug must be placed on the connector where normally the connecting cable to the operating terminal would be plugged in (part no. 710812).

Connecting cables for the control terminal ST (P/U)

The connecting cables serve two purposes: connection of the control terminal to the distribution box (24 VDC power supply and trip line) and to the locking unit on the door.

These connection cables are available in three lengths: 3 m, 5 m, 10 m. Important: the length of the cable to the locking unit is always just 2 m.

Before choosing the connecting cables the required Emergency-Open function must be decided on: either local Emergency Open (LNA) or global Emergency Open (GNA) (see page 08.010.00) as these are realized by a different set of cables (part nos. 710814-710816 or 710818-710820).

Set of connection plugs for individual wiring

If the above mentioned connection cables are not used, a set (4 pcs.) of connection plugs (part no. 710817) is required in order to be able to make the connections with a normal cable. The terminals dispose only of plug-in positions (sockets) and not of feeder clamps.

Connection cable for access controls or large-surface switches

This connection cable is also just plugged into the control terminal. At the other end of the cable are free leads with end sleeves.

Length: 2 m (part no. 710813)

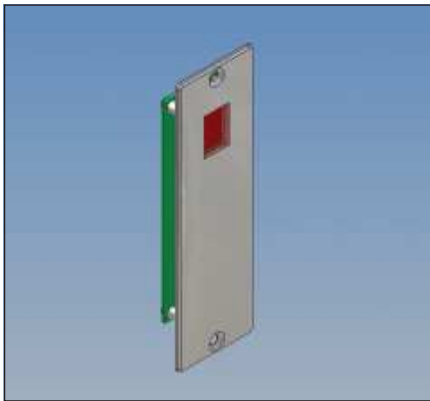

Interlock Control System - Time Control Unit

Some interlock systems require that some doors only open after a certain time delay, e.g. if the quality/temperature of air in the interlock must reach a certain level before the door to the cleanroom may open. The DICTATOR time control unit permits the blocking of max. 6 cleanroom doors against up to 6 "blackroom" doors. If one or several of the "blackroom" doors are opened during the locking time, the time control unit starts the count-down again. Only when the adjusted time has elapsed, the door to the cleanroom can be opened.

Functioning / Dimensions

The type of door (cleanroom or blackroom) is determined by the connection of the cables from the control terminals to the time control unit.

The required time lag (16 different values possible) is adjusted in the time control unit with the help of 4 DIP-switches. If a time different from the 16 adjusted time lags is required, this has to be indicated in the order as it has to be programmed in production.

The time control unit has a 7-segment display and an additional dot. If the time control unit is on, the dot of the display lights up. When the time control unit is activated by one of the connected terminals, the dot starts flashing (one flash per second). When all blackroom doors are closed the time count-down starts. The time control unit divides the adjusted time into 10 intervals and the display counts down from 9 to 0, thus indicating the remaining time during which the doors stay locked.

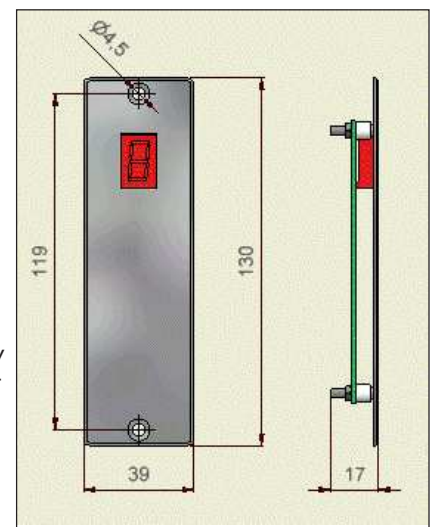

Models / Components

It is possible to connect up to 6 additional displays (part no. 710805) to the time control unit. Independent of the amount of additional displays there is always required one extender circuit module (part no. 710808).

The time control unit is connected with a normal cable to the distribution box (see page 08.015.00). For the connection of the additional displays and the extender circuit module the connection cables, part no. 710809 or 710810, are to be used. If their length is not sufficient, the connection has to be done on site. In this case a set of connection plugs, part no. 710 811, is required, one for each additional display.

Technical Data

Power consumption time control unit	24 VDC, max. 20 mA
Power consumption extender circuit module	24 VDC, max. 2 mA
Power consumption additional display	24 VDC, max. 10 mA
IP rating	IP 20
Operating temperature	-10 °C to +40 °C
Time lags	16 different time lags adjustable (0, 15, 20, 25, 30, 35, 40, 50, 60, 120, 180, 240, 300, 420, 540, 660 seconds) max. time lag 2,75 hours
Quantity of connectable doors	6 cleanroom and max. 6 "blackroom" doors

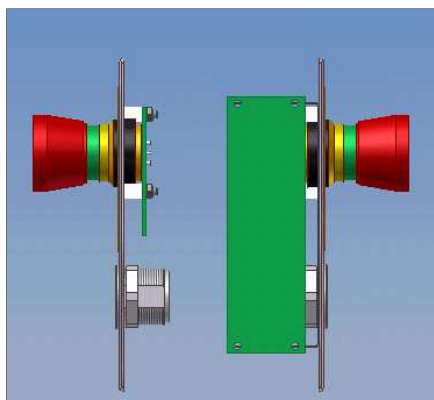

Interlock Control System - Order Information

On this page you will find a summary of the part numbers of all components described on the previous pages (see summary of the main components on page 08.011.00). For information regarding the power packs please see page 08.041.00 and following pages.

The doors of the interlock system can be locked either with the DICTATOR door lock TVR (see page 08.034.00) or a DICTATOR bar magnet (from page 08.019.00 on). When choosing the bar magnet make sure to select a 24 VDC magnet with a feedback contact.

Order Information Control Terminals

(see page 08.012.00)

Operating Terminals

(see page 08.013.00)

Emergency-Exit Terminal

Time Control Unit

(see page 08.017.00)

Installation Components

(see page 08.015.00 and following)

Control terminal ST P	Part no. 710800
Control terminal ST oN P without emergency-open switch	Part no. 710802
Control terminal ST U	Part no. 710825
Control terminal ST oN U without emergency-open switch	Part no. 710827
Operating terminal BT P	Part no. 710801
Operating terminal BT oN P without emergency-open switch	Part no. 710803
Operating terminal BT U	Part no. 710826
Operating terminal BT oN U without emergency-open switch	Part no. 710828
Emergency-exit terminal FT P (see page 08.014.00)	Part no. 710833
Time control unit ZS	Part no. 710805
Additional display ZA for the time control unit	Part no. 710806
Extender circuit module for additional displays	Part no. 710808
Distribution box VK for one Door	Part no. 710807
Distribution box VK for two doors	Part no. 710821
Connection cables for control terminal ST 3 m, LNA (local)	Part no. 710814
Connection cables for control terminal ST 5 m, LNA	Part no. 710815
Connection cables for control terminal ST 10 m, LNA	Part no. 710816
Connection cables for control terminal ST 3 m, GNA (global)	Part no. 710818
Connection cables for control terminal ST 5 m, GNA	Part no. 710819
Connection cables for control terminal ST 10 m, GNA	Part no. 710820
Plug-in connection cable control/operating terminal, 250 mm	Part no. 710809
Plug-in connection cable control/operating terminal, 1000 mm	Part no. 710810
Connection cable for access control or large-surface switch	Part no. 710813
Set of connection plugs for the control/operating terminal	Part no. 710811
Dummy plug for the control terminal - for stand-alone function	Part no. 710812
Set of connection plugs for ST for individual wiring	Part no. 710817
Flush box P for the control/operating terminal	Part no. 710829
Flush box U for the control/operating terminal	Part no. 710830
Surface box P for the control/operating terminal, white	Part no. 710831
Surface box P for the control/operating terminal, black	Part no. 710832
Flush box P for the emergency exit terminal	Part no. 710834
Surface box P for the emergency exit terminal, white RAL 9010	Part no. 710835

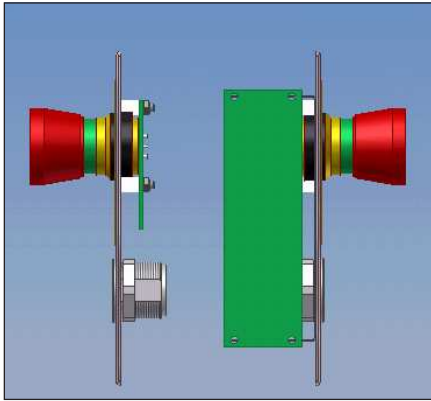

Interlock Control System - Setting of the Dependencies

The following matrix helps you to determine the position of the DIP-switches in the control terminal on each door. Just mark for each door which other door(s) may be open at the same time and which one(s) must stay locked (see example below).

There are 3 positions for the DIP-switches:

Position +: determines the door for which the dependencies are decided (base door)

Position -: this door is locked as long as the "base door" is open.

Position 0: this door can be opened even though the "base door" is open as well.

Cleanroom interlock system with 5 doors

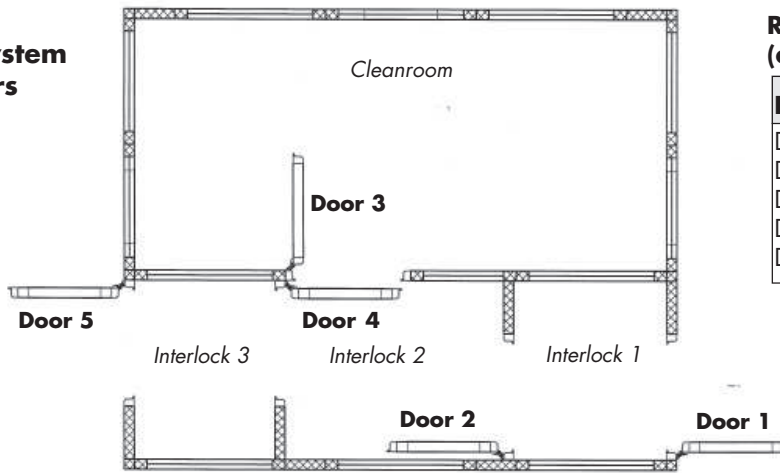

Required dependencies (determined by the customer)

Door open	Door locked
Door 1	Door 2
Door 2	Doors 1, 3 and 4
Door 3	Doors 2 and 4
Door 4	Doors 2, 3 and 5
Door 5	Door 4

Matrix for setting the positions of the Dip-switches

Door number No. of the base door	Admissible state of the other doors of the interlock system in dependency of the opened "base door"									
	1	2	3	4	5	6	7	8	9	10
1	+	-	0	0	0	0	0	0	0	0
2	-	+	-	-	0	0	0	0	0	0
3	0	-	+	-	0	0	0	0	0	0
4	0	-	-	+	-	0	0	0	0	0
5	0	0	0	-	+	0	0	0	0	0
6										
7										
8										
9										
10										

