

## RETSCH Product Navigator

### ■ Milling

- Jaw Crushers
- Rotor Mills
- Cutting Mills
- Mortar Grinders
- Disc Mills
- Ball Mills
  - MM 200
  - MM 400
  - PM 100
  - PM 200
  - PM 400

### ■ Sieving

### ■ Assisting

# Size reduction and homogenization with ball mills



## Fast and powerful grinding for unlimited applications

RETSCH ball mills are suitable for a wide range of applications. Depending on the model (planetary ball mill or mixer mill), they can be used for dry, wet or cryogenic grinding. Mixing, homogenizing, cell disruption, mechanical alloying and even colloidal grinding are further possible applications. Due to their versatility they can be used in virtually all sectors concerned with the mechanical treatment of solids in industry and research.

# **Retsch**<sup>®</sup>

**Solutions in Milling & Sieving**

**RETSCH ball mills** are used for the pulverization of soft, fibrous, hard and brittle materials. They achieve a very high final fineness down to the submicron range. The feed size depends on the mill and can have a maximum size of 10 mm. If the sample feed size is larger than this then the sample must first undergo preliminary size reduction.

**Preliminary size reduction**



For the coarse and preliminary size reduction of hard, brittle or even tough materials, the RETSCH jaw crushers have proven themselves in practice. In contrast, bulky, soft, fibrous or elastic materials are best prepared in RETSCH cutting mills.

**Sample dividers**



For the subsequent pulverization a **representative part-sample** must first be obtained, e.g. with the sample divider PT 100 from RETSCH.

**Pellet presses**



RETSCH offers two models of hydraulic pellet presses for preparing solid samples for XRF studies.

# Superiority in detail – technology from RETSCH

RETSCH offers a comprehensive range of ball mills for the preparation of soft to hard materials. The various models differ primarily from each other in their mode of operation.

- Mixer Mills MM 200, MM 400 . . . . . pages 4 - 8
- Planetary Ball Mills PM 100, PM 200, PM 400. . . . . pages 9 - 16

**RETSCH ball mills are the right choice whenever efficient pulverization and homogenization of soft to hard materials are required. Unique features and innovative details prove this.**

**Mixer Mill MM 400**

**Grinding jar attachment – simple and safe**

The unique grinding jar attachment system of the MM 400 allows quick, simple and safe clamping of the jars. The automatic centering and exact placement of the grinding jars optimizes the reproducibility of the grinding process. The **self-locking device** prevents the grinding jars from becoming loose during the grinding process.



**Cryogenic grinding – quick and efficient**



*Before grinding, the jars are immersed in liquid nitrogen (-196 °C) in the cryo box for approx. 2 - 3 minutes*

The Mixer Mill MM 400 is ideally suitable for cryogenic grinding. Sample material and grinding ball charge are placed in the screw-top stainless steel grinding jars, which are then immersed in liquid nitrogen. After having cooled down sufficiently, they are fastened in the quick-clamping device of the MM 400; this holds the grinding jars securely, even at extremely low temperatures. **After a grinding time of only 2 - 3 minutes a completely homogenized sample is obtained.** This procedure saves time and is particularly economical due to the very low consumption of liquid nitrogen.

## Planetary Ball Mills PM 100 / PM 200 / PM 400

### Safety and versatility

#### "comfort" grinding jars

Thanks to their many unique details, the "comfort" grinding jars make a great contribution to the particular safety of RETSCH planetary ball mills. More information about the grinding jars can be found on page 14.

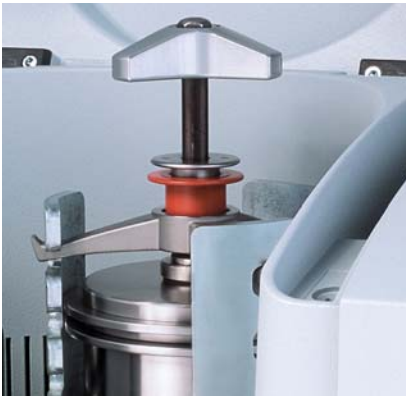

#### Quick-action clamping device

The patented quick-action clamping device is used in all RETSCH planetary ball mills. This allows the grinding jars to be inserted in the mills quickly and, above all, safely. The self-acting lock ensures that the grinding jars are seated correctly and securely.



### Controlled forces in single-station planetary ball mills

Planetary mills with a single grinding station require a counterweight for balancing purposes. In the Ball Mill PM 100 this counterweight can be adjusted on an inclined guide rail. In this way the different heights of the centers of gravity of differently-sized grinding jars can be compensated in order to avoid disturbing oscillations of the machine.

Any remaining vibrations are compensated by feet with some free movement (**Free-Force Compensation Sockets**). This **innovative FFCS technology** is based on the d'Alembert principle and allows very small circular movements of the machine housing that result in an automatic mass compensation. The laboratory bench is only subjected to minimal frictional forces generated in the feet.

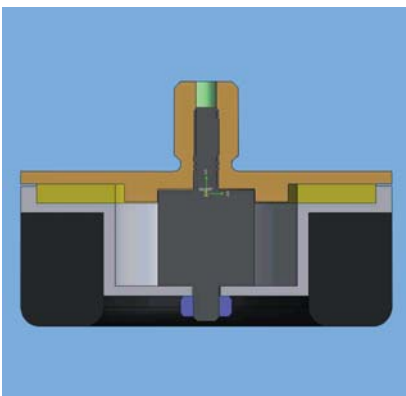

*The special design of the feet effectively compensates the free forces and ensures a low-vibration operation.*

**In this way the PM 100 ensures a quiet and safe operation with maximum compensation of vibrations even with the largest pulverization forces inside the grinding jars and therefore can be left on the bench unsupervised.**



*For optimal balancing the counterweight of the PM 100 can slide up an inclined guide rail*

# Mixer Mills MM 200 and MM 400

## Grinding, mixing, disrupting small amounts of sample



MM 200

RETSCH Mixer Mills MM 200 and MM 400 are laboratory "all-rounders". They have been developed specially for **grinding, homogenizing and mixing of small sample amounts** in only a few seconds. They are also perfectly suitable for the **disruption of biological cells** as well as for DNA/RNA extraction. The MM 400 can also be used for **wet and cryogenic grinding**.

The mixer mills can pulverize two samples from 0.2 to 20 ml at the same time. For cell disruption it is possible to process 20 samples simultaneously. The Mixer Mills MM 200 and MM 400 operate so effectively that the sample is hardly warmed at all due to the very short grinding time. **Thus most materials can be pulverized and mixed at ambient temperature, without any cooling.**

### Benefits at a glance

- Quick, efficient pulverization and homogenization
- High sample throughput due to short grinding times and two grinding stations
- Reproducible results by digital preselection of grinding time and vibrational frequency
- Large range of grinding jars
- Up to 9 parameter combinations can be stored
- 2-year warranty, CE-conforming

### MM 200 and MM 400 – high-performance mixer mills for many types of material

The RETSCH Mixer Mills MM 200 and MM 400 are used for size reduction and pulverization of hard, medium-hard and brittle samples as well as for soft, elastic or fibrous ones such as **tissue, bones, hair, chemicals, drugs, coated and uncoated tablets, minerals, ores, alloys, glass, ceramics, soils, sludge, plant parts, cereal grains, oil seeds, plastics, waste samples, wool and textiles, to name but a few.**

With their ability to process small sample amounts to analytical fineness quickly and reproducibly, RETSCH mixer mills are the ideal devices to

prepare pressed tablets for subsequent **XRF analysis**.

Mixer mills are primarily used in the following sectors:

- Agriculture
- Biology and Biotechnology
- Ceramics and Glass
- Chemicals and Plastics
- Environmental Research
- Foodstuffs
- Forensic Science
- Medicine and Pharmaceuticals
- Metallurgy and Metallurgical Engineering
- Mineralogy
- New Materials Research

### MM 200 and MM 400 technology

The grinding jars perform oscillations in a horizontal position. The inertia of the grinding balls causes them to impact with high energy on the sample material at the rounded ends of the grinding jars and pulverize it. Also, the movement of the grinding jars combined with the movement of the balls result in the intensive mixing of the sample. The degree of mixing

can be increased even further by using several smaller balls. If many very small balls are used (e.g. glass beads) then, for example, biological cells can be disrupted. The large frictional impact effects between the beads ensure effective cell disruption.

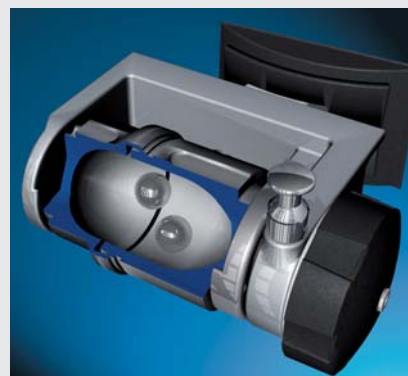



## Maximum reproducibility



Both mills are particularly easy to use. The vibrational intensity can be set accurately from 3 to 25/30 hertz. An electronic speed control keeps this value constant during the entire grinding process. The grinding time can be preset digitally in the range from 10 seconds to 99 minutes. All instrument parameters are retained during standby operation for subsequent processes. Up to 9 parameter combinations can be stored. At the same time this ensures the highest degree of reproducibility for the following sample preparation processes.

## Wet grinding

The screw-top grinding jars provide the ideal preconditions for wet grinding with mixer mills. A Teflon seal prevents the escape of liquids and particles even at maximum vibrational frequency.

## Cryogenic grinding with the Mixer Mill MM 400

Thermally-sensitive and elastic substances can be successfully processed by external cooling of the grinding jars. However, jars made from agate or ceramics should not be cooled with liquid nitrogen in order to avoid damage during the grinding process.

The screw-top grinding jars are particularly suitable for cryogenic grinding, as they remain hermetically sealed until they have regained room temperature. This prevents atmospheric humidity from con-

MM 400



## MM 400 – the mixer mill with unsurpassed performance, safety and comfort

Due to the increased oscillation radius of the MM 400, the energy input is approx. 30% greater than that of the MM 200. This results in **more fineness in less time**. In addition, large grinding jars with a capacity of 35 ml and 50 ml are available for the MM 400. In these jars, up to 20 ml of sample material with a **feed size of up to 8 mm** can be ground. Clamping and removing the grinding jars is easy and safe. The special **self-centering of the grinding jars** ensures that they are always located in exactly the same position, which optimizes the reproducibility of the grinding process. The **self-locking clamping device** fixes the grinding jars with maximum security.

## Advantages MM 400

**The Mixer Mill MM 400 is a real multi-talent** with nearly unlimited applications:

- Reproducible **dry grinding**, e.g. for sample preparation for XRF analyses
- Loss-free **wet grinding** due to screw-top, leak-proof grinding jars
- Convenient **cryogenic grinding** of thermally sensitive products without long pre-cooling times and with a minimum consumption of liquid nitrogen
- Efficient **disruption** of plant or animal tissues or cell suspensions in adapter racks for 5 or 10 reaction vials



densing on the cold sample as water vapor which could penetrate the sample and falsify the analytical results.

A special cryo kit is available for precooling the grinding jars in liquid nitrogen; it consists of:  
2 insulated containers (1 and 4 liter),  
2 pairs of grinding jar tongs  
1 pair of safety glasses.



# Selection guide for mixer mills

The **MM 200** is mainly used for the size reduction of small amounts of sample.

The **MM 400**, with 30% higher energy, can pulverize samples finer and faster, with optimum reproducibility. Its

convenient self-locking clamp allows the use of large jars up to 50 ml and pre-chilled jars of stainless steel.

Performance data	MM 200	MM 400
Field of application	size reduction, mixing, homogenization, cell disruption	
Feed material	hard, medium-hard, soft, brittle, elastic, fibrous	
Feed size*	up to 6 mm	up to 8 mm
Final fineness*	approx. 10 µm	approx. 5 µm
Batch/Sample volume	max. 2 x 10 ml	max. 2 x 20 ml
Typical mean grinding time	2 minutes	2 minutes
Possible applications		
Dry grinding	yes	yes
Wet grinding	no	yes
Cryogenic grinding	no	yes
Cell digestion with reaction vials	max. 10 x 2.0 ml	max. 20 x 2.0 ml
Suitable grinding jars		
Grinding jar with push-fit lids	1.5 - 25 ml	no
Grinding jars with screw-top lids	no	1.5 - 50 ml
Self-centering clamping device	no	yes
No. of grinding stations	2	2
Digital preselection of vibrational frequency	3 - 25 Hz (180 - 1500 min <sup>-1</sup> )	3 - 30 Hz (180 - 1800 min <sup>-1</sup> )
Digital preselection of grinding time	10 s - 99 min	10 s - 99 min
Memory for parameter combinations	9	9
Technical data		
Power consumption	100 W	150 W
W x H x D	371 x 266 x 461 mm	371 x 266 x 461 mm
Net weight	approx. 25 kg	approx. 26 kg
Noise values (Noise measurement according to DIN 45635-31-01-KL3)		
Emission value with regard to workplace*	L <sub>pAeq</sub> 65 dB(A)	L <sub>pAeq</sub> 65 dB(A)
Measuring conditions:		
Feed material	8 ml broken quartz pebbles, approx. 4.0 - 6.0 mm	8 ml broken quartz pebbles, approx. 4.0 - 6.0 mm
Grinding jars used	2 x 25 ml steel	2 x 25 ml steel
Grinding balls used	1 steel ball 20 mm dia.	1 steel ball 20 mm dia.

\*depending on feed material and instrument configuration/settings

## Cell disruption with RETSCH mixer mills

Smallest amounts of sample, such as are normally used for the isolation of DNA and RNA, can be prepared in disposable reaction vials (e.g. Eppendorf). Adapter racks of PTFE which accommodate either 5 or 10 disposable reaction vials can be used for this.

In the mixer mills, efficient disruption is achieved so quickly that no additional cooling is necessary.



Adapter rack for:  
 5 reaction vials 1.5 and 2.0 ml (1)  
 10 reaction vials 1.5 and 2.0 ml (2)  
 10 reaction vials 0.2 ml (3)

# Grinding jars and grinding balls for versatile use

The grinding result is greatly influenced by the grinding tools. The choice of jar volume, ball charge and material depend on the type and amount of sample. In order not to falsify the subsequent analytical determination, a neutral-to-analysis material should be selected.



Screw-top grinding jars for MM 400



Grinding jars with push-fit lids for MM 200

The pulverization energy is determined by the density and weight of the ball material. The higher the ball weight and density, the higher the pulverization energy. The jar and balls should always be made of the same material. The table shown below is intended to help you to select suitable grinding tools.

In addition to the standard grinding jars with push-fit lids for the MM 200, superior screw-top grinding jars for the MM 400 are available.

## Advantages of the screw-top grinding jars

- Exceptionally simple and safe handling
  - Dust-proof and air-tight (no loss of material, no escape of e.g. inert atmosphere)
  - Suitable for wet and cryogenic grinding
  - Ultimate reproducibility by automatic centering and uniform jar design
  - Ergonomic gripping flanges on jar and lid
  - Stainless steel protective jacket (for agate, zirconium oxide and tungsten carbide jars)
- The screw-top grinding jars have been specially designed for the Mixer Mill MM 400.

In addition to the instrument settings, the filling level of the jar is also of crucial importance for the success of the grinding process in mixer mills. A jar filling should consist of about 1/3 sample and 1/3 ball charge. The remaining third is the free jar volume that is necessary for the free movement of the balls. The following table provides guidelines.

### Grinding jar filling levels – guidelines for sample volume and ball charge

Grinding jar nominal volume	Sample amount	Max. feed size	Recommended ball charge						
			Ø 5 mm	Ø 7 mm	Ø 9/10 mm	Ø 12 mm	Ø 15 mm	Ø 20 mm	Ø 25 mm
1.5 ml	0.2 – 0.5 ml	1 mm	1 to 2 pcs.	-	-	-	-	-	-
5.0 ml	0.5 – 2.0 ml	2 mm	-	1 to 2 pcs.	-	-	-	-	-
10.0 ml	2.0 – 4.0 ml	4 mm	-	-	1 to 2 pcs.	1 to 2 pcs.	-	-	-
25.0 ml	4.0 – 10.0 ml	6 mm	-	-	-	-	1 pc.	-	-
35.0 ml	6.0 – 15.0 ml	6 mm	-	-	-	-	-	1 pc.	-
50.0 ml	8.0 – 20.0 ml	8 mm	-	-	-	-	-	-	1 pc.

### Material composition guidelines

Grinding jar	Material no.			approx. hardness	Material analysis (in %)
		MM 200	MM 400		
Hardened steel	1.2080	■	■	62-63 HRC	Fe (84.89), Cr (12), C (2.2), Mn (0.45), Si (0.4), P (0.03), S (0.03)
Stainless steel	1.4034	■	-	48-52 HRC	Fe (82.925), Cr (14.5), C (0.5), Mn (1), Si (1), P (0.045), S (0.03)
	1.4112	-	■	55-57 HRC	Fe (76.5), Cr (19), Mo (1.3), Mn (1), Si (1), C (0.95), V (0.12), P (0.04), S (0.03)
Tungsten carbide		■	■	1180-1280 HV 30	WC (94), Co (6)
Agate		■	■	6.5-7 Mohs	SiO <sub>2</sub> (99.91), Al <sub>2</sub> O <sub>3</sub> (0.02), Na <sub>2</sub> O (0.02), Fe <sub>2</sub> O <sub>3</sub> (0.01), K <sub>2</sub> O (0.01), MnO (0.01), MgO (0.01), CaO (0.01)
Zirconium oxide*		■	■	1200 HV	ZrO <sub>2</sub> (94.5), Y <sub>2</sub> O <sub>3</sub> (5.2), SiO <sub>2</sub> / MgO/ CaO/ Fe <sub>2</sub> O <sub>3</sub> / Na <sub>2</sub> O/ K <sub>2</sub> O (< 0.3)

The above percentages are mean values. We reserve the right to make alterations.

\*Yttrium-part-stabilized

## Mixer mills order data

Mixer Mill MM 200					Item No.
MM 200 (please order grinding jars and grinding balls separately)					
MM 200	for 100-240 V, 50/60 Hz				20.746.0001
Grinding jars with lids for MM 200	1.5 ml	5 ml	10 ml	25 ml	
Hardened steel	-	-	-	-	02.462.0052
Stainless steel	02.462.0057	02.462.0059	02.462.0061	02.462.0119	
Tungsten carbide	-	01.462.0115	01.462.0009	-	
Agate	-	01.462.0113	01.462.0008	-	
Zirconium oxide	-	-	01.462.0194	01.462.0195	
Teflon	-	-	02.462.0184	02.462.0051	
Mixing beakers of polystyrene, 28 ml, 100 pcs.					22.041.0003

Mixer Mill MM 400							Item No.
MM 400 with quick-clamping device (please order grinding jars and grinding balls separately)							
MM 400	for 100-240 V, 50/60 Hz						20.745.0001
Grinding jars with screw-top lid	1.5 ml	5 ml	10 ml	25 ml	35 ml	50 ml	
Hardened steel	-	-	-	01.462.0237	-	-	
Stainless steel	01.462.0230	01.462.0231	01.462.0236	02.462.0213	01.462.0214	01.462.0216	
Tungsten carbide	-	-	01.462.0235	01.462.0217	-	-	
Agate	-	01.462.0232	01.462.0233	-	-	-	
Zirconium oxide	-	-	01.462.0234	01.462.0201	01.462.0215	-	
Teflon	-	-	-	01.462.0238	01.462.0244	-	
Accessories							
Jar wrench for screw-top jars, 25 ml tungsten carbide and all grinding jars 35 ml, 50 ml							02.486.0001
Cryo kit for cooling grinding jars with liquid nitrogen							22.354.0001

Grinding balls for MM 200 and MM 400									Item No.
Grinding balls	5 mm Ø	7 mm Ø	9 mm Ø	10 mm Ø	12 mm Ø	15 mm Ø	20 mm Ø	25 mm Ø	
Hardened steel	05.368.0029	05.368.0030	05.368.0031	05.368.0059	05.368.0032	05.368.0108	-	-	
Stainless steel	05.368.0034	05.368.0035	05.368.0036	05.368.0063	05.368.0037	05.368.0109	05.368.0062	05.368.0105	
Tungsten carbide	05.368.0038	05.368.0039	05.368.0040	05.368.0071	05.368.0041	05.368.0110	-	-	
Agate	05.368.0024	05.368.0025	05.368.0026	05.368.0067	05.368.0027	-	-	-	
Zirconium oxide	-	-	-	-	05.368.0096	05.368.0113	05.368.0093	-	
Teflon with steel core	-	-	-	05.368.0045	05.368.0046	05.368.0114	05.368.0047	-	
Polyamide*	05.368.0042	05.368.0043	05.368.0044	-	05.368.0003	-	-	-	

\*for mixing beakers of polystyrene

Accessories for cell and tissue disruption with MM 200 and MM 400							Item No.		
Adapter racks, PTFE, for reaction vials for MM 200 and MM 400									
Adapter rack	for 10 reaction vials,	1.5 and 2.0 ml (for MM 400 only)					22.008.0008		
Adapter rack	for 5 reaction vials,	1.5 und 2.0 ml					22.008.0005		
Adapter rack	for 10 reaction vials,	0.2 ml					22.008.0006		
Safe-Lock reaction vials					0.2 ml	1.5 ml	2.0 ml		
Safe-Lock reaction vials, 1000 pcs.					22.749.0004	22.749.0002	22.749.0001		
Grinding balls for reaction vials and wet/ultra fine grinding					2 mm Ø	3 mm Ø	4 mm Ø	5 mm Ø	
Stainless steel	500 g					22.455.0010	22.455.0011	-	
Stainless steel	approx. 200 pcs.					-	22.455.0002	22.455.0001	22.455.0003
Tungsten carbide	approx. 200 pcs.					-	22.455.0006	22.455.0005	22.455.0004
Zirconium oxide	500 g					05.368.0089	05.368.0090	-	-
Zirconium oxide	approx. 200 pcs.					-	22.455.0007	-	22.455.0009
Glass beads for reaction vials			0.10-0.25 mm Ø	0.25-0.50 mm Ø	0.50-0.75 mm Ø	0.75-1.00 mm Ø	1.00-1.50 mm Ø		
Glass	500 g			22.222.0001	22.222.0002	22.222.0003	22.222.0004	22.222.0005	



# Planetary Ball Mills

## PM 100, PM 200 and PM 400

### Powerful and fast – Grinding down to the nano range

RETSCH planetary ball mills are used wherever the highest degree of fineness is required. Apart from the classical mixing and size reduction processes, the mills also meet all the technical requirements for colloidal grinding and have the energy input necessary for mechanical alloying processes.

The extremely high centrifugal forces of the planetary ball mills result in very high pulverization energy and therefore **short grinding times**.

**Together with the “comfort” grinding jars these planetary ball mills offer the highest possible degree of performance, safety and reliability.**



RETSCH planetary ball mills pulverize and mix soft, medium-hard to extremely hard, brittle and fibrous materials. Dry and wet grinding can be carried out. **Minerals, ores, alloys, chemicals, glass, ceramics, plant parts, soils, sewage sludge, household and industrial waste and many other materials** can be pulverized easily, quickly and without loss. Planetary ball mills are used successfully **in virtually all industry and research sectors**, in particular wherever the highest demands are placed on purity,

quickness, fineness and reproducibility.

The main fields of application for planetary ball mills are:

- Agriculture
- Biology and Biotechnology
- Ceramics and Glass
- Chemicals
- Construction Materials
- Environmental Research
- Medicine
- Mineralogy and Metallurgy

to name just a few.

Planetary ball mills are available in versions with 1, 2 and 4 grinding stations. The freely selectable machine settings, comprehensive range of grinding jars made from top-quality materials as well as the numerous possible ball charge combinations (number and ball size) allow **individual adaptation of the grinding parameters to the particular size reduction task.**

# Planetary ball mills

## PM 100, PM 200 and PM 400

### Benefits at a glance

- Extreme speeds for particularly high final fineness down to the submicron range
- Different speed ratios available
- Grinding jar volumes from 12 ml to 500 ml, in 6 different materials
- Suitable for long-term trials and continuous use
- Automatic direction reversal helps to avoid agglomerations
- FFCS technology compensates vibrations (PM 100)
- Reproducible results due to energy and speed control
- Measurement of input energy helps to optimize grinding parameters
- 10 combinations of grinding parameters can be stored
- Graphics display and ergonomic 1-button operation
- Automatic grinding chamber ventilation
- 2-year warranty, CE-conforming

### Innovative technology for increased safety

A **well thought-out operating concept** and, above all, the **optimized safety aspects** set new standards in this product segment and offer the user the possibility of carrying out size reduction tasks optimally and safely. The powerful and maintenance-free mill drive guarantees a constant controlled speed even **for continuous use** in long-term trials and under maximum load.



The planetary ball mills offer a high degree of operating convenience, safety and versatility. Thanks to the **programmable starting time** grinding jobs can be started at night. If a power cut should occur during operation, the mills save all parameters including the remaining grinding time at that point of time. When the power supply is restored the grinding process can be resumed.

A **built-in fan with standstill monitoring** cools the grinding jars during operation. The extraction volume per hour is greater than the 20-fold grinding chamber volume.

All mills are equipped with an automatic cover closure which prevents the machine from starting without being properly closed. After the grinding process is finished, the cover unlocks automatically. It can only be opened when the mill is at a complete standstill.

### New technology with maximum operating comfort

The Planetary Ball Mills feature a very convenient operator guidance. All the relevant data can be entered or called up via a graphics display with 1-button operation:

- speed
- grinding time
- energy input
- grinding direction reversal with selection of running and pause times
- starting time
- remaining running time
- display of drive load factor
- operating hours

- clear text error messages
- service intervals.

10 combinations of speed, grinding time and interval settings can be stored for repetitive grinding tasks.

**With multi-language graphical menu guidance.**

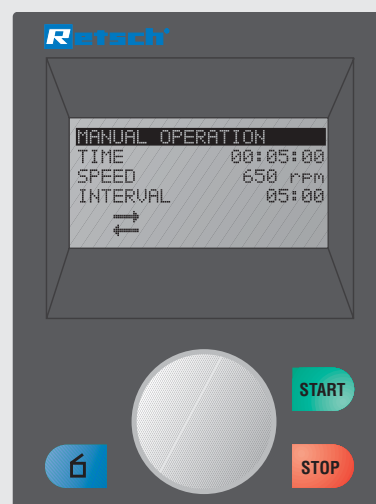

# Benchtop instruments

## PM 100, PM 100 CM and PM 200

**RETSCH planetary ball mills are available in different versions.** Please refer to page 13 for a complete overview of the different performance features.



PM 100

PM 100 CM



PM 200

### Type PM 100

The convenient bench-top model with 1 grinding station for grinding jars with a nominal volume of 12 to 500 ml. The PM 100 features Free-Force-Compensation-Sockets (FFCS) which ensure a safe low-vibration run and minimal oscillation transfers to the laboratory bench.

### Type PM 100 CM

The PM 100 CM operates in centrifugal mode, i.e. the speed ratio of sun wheel to grinding jar is 1:-1 (PM 100: 1:-2). This results in a different ball movement which leads to a more gentle size reduction process with less abrasion.

### Type PM 200

The bench-top model PM 200 with 2 grinding stations for grinding jars with a nominal volume of 12 to 125 ml. The larger sun wheel diameter results in a higher energy input when compared to the PM 100.

### Planetary ball mill technology

The grinding jars are arranged eccentrically on the sun wheel of the planetary ball mill. The direction of movement of the sun wheel is opposite to that of the grinding jars in the ratio 1:-2 (or 1:-2.5 or 1:-3).

The grinding balls in the grinding jars are subjected to super-imposed rotational movements, the so-called **Coriolis forces**. The difference in speeds between the balls and grinding jars produces an interaction between frictional and impact forces, which releases high dynamic energies.

The interplay between these forces produces the high and **very effective degree of size reduction** of the planetary ball mill.

The PM 100 CM operates with a speed ratio of 1:-1 (centrifugal mode). The centrifugal forces produced by the rotation force the sample and the grinding balls against the inner wall of the grinding jar, where size reduction takes place primarily by pressure and friction.

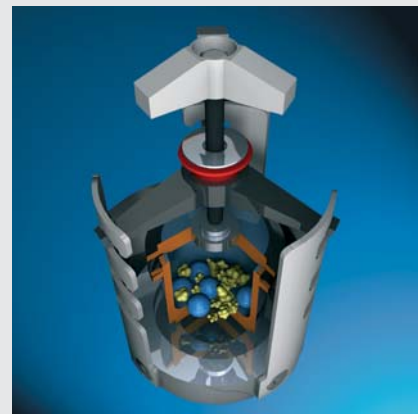

# Floor models

## PM 400 and PM 400 MA

### Type PM 400

The robust floor model PM 400 with 4 grinding stations for grinding jars with a nominal volume of 12 to 500 ml. It can grind up to 8 samples simultaneously down to the submicron range thus generating a high sample throughput. The PM 400 is also available with 2 grinding stations. The freely selectable speed from 30 to 400 min<sup>-1</sup> in combination with an effective sun wheel diameter of 300 mm allow for a particularly high energy input. Thus, the PM 400 produces samples with **analytical fineness in no time.**

### Type PM 400 MA

To generate the high energy input which is required for mechanical alloying of hard-brittle materials, the PM 400 is available as „MA“ type with a speed ratio of 1:-2.5 or 1:-3.



### Mechanical alloying with RETSCH planetary ball mills

The mechanical alloying of materials in a grinding process to form new materials with new properties is no problem for RETSCH planetary ball mills. For ductile metals the speed ratio of the jar to the sun wheel of 1:-2 is fully adequate in most cases, as the impact energy produced by the ball charge is large enough to form an alloy.

However, greater energy is required for hard-brittle materials such as covalently bound semiconductors. The PM 400 MA with an increased speed ratio of 1:-2.5 or 1:-3.0 is available for such applications. The best speed ratio and all other grinding parameters must be determined experimentally for the specific product.





# The ideal planetary ball mill for your requirements

RETSCH planetary ball mills are available in different versions

Performance data	PM 100 / PM 100 CM	PM 200	PM 400 / PM 400 MA
Field of application	pulverizing, mixing, homogenizing, colloidal milling, mechanical alloying		
Feed material	soft, hard, brittle, fibrous – dry or wet		
Feed size*	<10 mm	<4 mm	<10 mm
Final fineness*	<1 µm	<1 µm	<1 µm
For colloidal grinding	<0.1 µm	<0.1 µm	<0.1 µm
Batch/Sample volume	max. 1 x 220 ml	max. 2 x 50 ml	max. 4 x 220 ml
with stacked grinding jars	max. 2 x 20 ml	-	max. 8 x 20 ml
No. of grinding stations	1	2	4 or 2
Suitable grinding jars „comfort“			
12 ml / 25 ml / 50 ml / 80 ml	1 or 2	2	2, 4 or 8
125 ml	1	2	2 or 4
250 ml / 500 ml	1	-	2 or 4
Speed ratio	1 : -2 / 1 : -1	1 : -2	1 : -2 / 1 : -2.5 or 1 : -3
Sun wheel speed	100 - 650 min <sup>-1</sup>	100 - 650 min <sup>-1</sup>	30 - 400 min <sup>-1</sup>
Max. speed of the jars	1300 min <sup>-1</sup> / 650 min <sup>-1</sup>	1300 min <sup>-1</sup>	800 min <sup>-1</sup> / 1000 min <sup>-1</sup> or 1200 min <sup>-1</sup>
Effective sun wheel diameter	141 mm	157 mm	300 mm
Digital grinding time setting			
(hours:minutes:seconds)	00:00:01 to 99:59:59	00:00:01 to 99:59:59	00:00:01 to 99:59:59
Direction reversal	yes	yes	yes
Interval time (minutes:seconds)	00:00:01 to 99:59:59	00:00:01 to 99:59:59	00:00:01 to 99:59:59
Pause time (minutes:seconds)	00:00:01 to 99:59:59	00:00:01 to 99:59:59	00:00:01 to 99:59:59
Measurement of input energy possible	yes	yes	yes
Serial interface	yes	yes	yes
*depending on feed material and instrument configuration/settings			
Technical data			
Power consumption	approx. 1250 W (VA)	approx. 1250 W (VA)	approx. 2100 W (VA)
Nominal Power	750 W	750 W	1500 W
W x H x D	630 x 468 x 415 mm	630 x 468 x 415 mm	836 x 1220 x 780 mm
Net weight	approx. 80 kg / approx. 86 kg	approx. 72 kg	approx. 290 kg
Noise values (Noise measurement according to DIN 45635-31-01-KL3)			
Emission value with regard to workplace	L <sub>pAeq</sub> up to 85 dB(A)	L <sub>pAeq</sub> up to 80 dB(A)	L <sub>pAeq</sub> up to 85 dB(A)
*depending on feed material, grinding jar volume, ball charge and selected speed			

## Speed ratios

The working principle of the planetary ball mills is based on the relative rotational movement between the grinding jar and the sun wheel. In addition to the sun wheel diameter and speed of rotation this speed ratio is decisive for the energy input and therefore for the results of the size reduction process. **The higher the speed ratio, the more energy is generated.**

There are planetary ball mills with different speed ratio settings. For exam-

ple, a ratio of 1:-1 means that each time that the sun wheel rotates the grinding jar also rotates exactly once in the opposite direction (indicated by the minus sign). With a speed ratio of 1:-2 the grinding jar rotates twice for each sun wheel rotation. In order to follow the rotational movement of the grinding jar you have to imagine that you are standing at the center of the sun wheel. During the sun wheel rotation you will see the red reference point exactly twice, i.e. the grinding jar has rotated twice (see illustration).

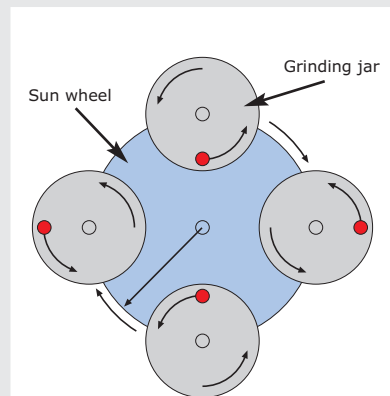

Diagram: speed ratio 1:-2

# "comfort" grinding jars for PM 100, PM 200 and PM 400

## Grinding jars for excellent grinding results

The performance and the result of sample preparation are also determined by the choice of the grinding jar and its ball charge. The choice depends on the amount of sample and the final fineness and purity of the ground sample that are necessary for the subsequent analysis.

The "comfort" range of grinding jars has been specially designed for extreme working conditions such as long-term trials, wet grinding, high mechanical loads and maximum speeds as well as for mechanical alloying.

In the PM 100 and PM 400 each grinding station can accommodate 2 stacked 12 - 50 ml "comfort" grinding jars. The 50 ml grinding jars require an additional adapter, the smaller grinding jars can be stacked directly.



## The unique advantages of "comfort" grinding jars

- Unusually simple and safe handling
- Safe, non-slip seating with built-in anti-rotation device and conical base centering
- O-ring for gas-tight and dust-proof seal
- User-friendly gripping flanges on jar and lid
- Gap between jar and edge of lid for easy opening
- Stainless steel protective jacket (for agate, sintered aluminum oxide, zirconium oxide and tungsten carbide grinding jars)
- Grinding jar identification (item number, material and volume)
- Labeling field (e.g. for sample information)

### Grinding jar filling levels – guidelines for sample volume and ball charge

Grinding jar nominal volume	Sample amount	Max. feed size	PM			Recommended ball charge			
			100	200	400	Ø 10 mm	Ø 20 mm	Ø 30 mm	Ø 40 mm
12 ml	up to 5 ml	<1 mm	■	■	■	5 pcs.	-	-	-
25 ml	up to 10 ml	<1 mm	■	■	■	8 pcs.	-	-	-
50 ml	5 - 20 ml	<3 mm	■	■	■	10 pcs.	3 pcs.	-	-
80 ml	10 - 35 ml	<4 mm	■	■	■	25 pcs.	5 pcs.	-	-
125 ml	15 - 50 ml	<4 mm	■	■	■	30 pcs.	7 pcs.	-	-
250 ml	25 - 120 ml	<6 mm	■	-	■	50 pcs.	15 pcs.	6 pcs.	-
500 ml	75 - 220 ml	<10 mm	■	-	■	100 pcs.	25 pcs.	8 pcs.	4 pcs.

### Material composition guidelines

Grinding jar	Material no.	approx. hardness	Material analysis (in %)
Hardened steel	1.2080	62-63 HRC	Fe (84.89), Cr (12), C (2.2), Mn (0.45), Si (0.4), P (0.03), S (0.03)
Stainless steel	1.4034	48-52 HRC	Fe (82.925), Cr (14.5), Mn (1), Si (1), C (0.5), P (0.045), S (0.03)
Tungsten carbide		1180-1280 HV 30	WC (94), Co (6)
Agate		6.5-7 Mohs	SiO <sub>2</sub> (99.91), Al <sub>2</sub> O <sub>3</sub> (0.02), Na <sub>2</sub> O (0.02), Fe <sub>2</sub> O <sub>3</sub> (0.01), K <sub>2</sub> O (0.01), MnO (0.01), MgO (0.01), CaO (0.01)
Sintered aluminum oxide		1750 HV	Al <sub>2</sub> O <sub>3</sub> (99.7), MgO (0.075), SiO <sub>2</sub> (0.075), CaO (0.07), Fe <sub>2</sub> O <sub>3</sub> (0.01), Na <sub>2</sub> O (0.01)
Zirconium oxide*		1200 HV	ZrO <sub>2</sub> (94.5), Y <sub>2</sub> O <sub>3</sub> (5.2), SiO <sub>2</sub> / MgO/ CaO/ Fe <sub>2</sub> O <sub>3</sub> / Na <sub>2</sub> O/ K <sub>2</sub> O (< 0.3)

The above percentages are mean values. We reserve the right to make alterations.

\*Yttrium-part-stabilized

# Accessories for grinding jars „comfort“

## Optimum safety during wet grinding and under inert atmosphere

The planetary ball mills are not only suitable for dry grinding but also for wet grinding, e.g. for the production of colloidal systems. The **„comfort“ grinding jars** offer maximum safety. They are gas-tight and dust-proof and can be equipped with special **safety closure devices**. Thus over pressure which may build up during and after the wet grinding process cannot escape.

The **aeration cover** is used to create an inert atmosphere in the grinding jar. **The safety closure device** permits the gas-tight handling inside and outside of a glovebox and ensures the safe transport of the grinding jar.



Grinding jar „comfort“ with safety closure device



Aeration cover

# Pressure and temperature measuring system PM GrindControl



In order to understand the processes which occur during grinding with ball mills (e.g. chemical reactions, phase changes), it is helpful to record the most important thermodynamic parameters: pressure and temperature. Planetary ball mills are frequently used for the development of new materials by mechanical alloying due to their high energy input. The processes and reactions which take

place in the grinding jar during grinding can be monitored and controlled.

The PM GrindControl is available for stainless steel grinding jars of 250 ml and 500 ml. A transmitter which is integrated in the jar lid sends digital signals to a stationary receiver which is connected to a PC. **Up to 200 values are measured per second** (single transmission mode). The transmission protocol is a very safe industry standard. Once the data is transmitted to the PC, it can easily be processed with established office programs.

The complete system including accessories is delivered in an aluminum case.

## Benefits at a glance

- Measurement ranges  
gas pressure: 0 - 500 kPa  
temperature: 0 - 200 °C
- No modification of the mill required
- Indoor range up to 20 m
- Operating time with fully charged accumulator 80 h
- Evaluation of data with Windows XP/Vista
- Multilingual software

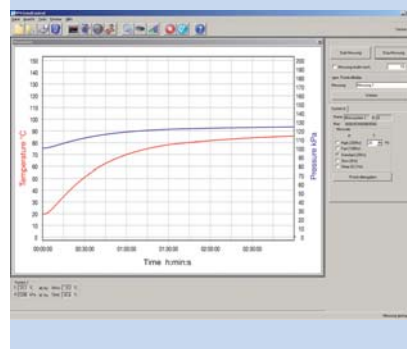

## Planetary ball mills order data

Planetary Ball Mills PM 100, PM 200, PM 400							Item No.
PM 100 (please order grinding jars and grinding balls separately)							speed ratio
PM 100	for 230 V, 50/60 Hz	with 1 grinding station	1 : -2				20.540.0001
PM 100 CM	for 230 V, 50/60 Hz	with 1 grinding station	1 : -1 centrifugal mode for gentle size reduction				20.520.0001
PM 200 (please order grinding jars and grinding balls separately)							speed ratio
PM 200	for 230 V, 50/60 Hz	with 2 grinding stations	1 : -2				20.640.0001
PM 400 mounted on casters (2 x lockable) (please order grinding jars and grinding balls separately)							
PM 400	for 1 x 220-230 V, 50-60 Hz	with 4 grinding stations	1 : -2				20.535.0001
PM 400/2	for 1 x 220-230 V, 50-60 Hz	with 2 grinding stations	1 : -2				20.535.0005
PM 400 MA	for 220-230 V, 50/60 Hz	with 4 grinding stations	1 : -2.5 special version for mechanical alloying				20.535.0007
PM 400 MA	for 220-230 V, 50/60 Hz	with 4 grinding stations	1 : -3 special version for mechanical alloying				20.535.0008
Accessories							
Add-on weight for PM 100 (if total weight of grinding jar, grinding balls, sample material and accessories is >7.3 kg)							22.221.0002
Other electrical versions available for the same price							
Measuring system PM GrindControl for PM 100 and PM 400							Item No.
Pressure and temperature measuring system PM GrindControl, incl. measuring transceiver, stationary transceiver, software, case and grinding jar							
PM GrindControl with grinding jar „comfort“ 250 ml, stainless steel, for PM 100 and PM 400							22.782.0004
PM GrindControl with grinding jar „comfort“ 500 ml, stainless steel, for PM 100 and PM 400							22.782.0005
„comfort“ grinding jars for PM 100, PM 200 and PM 400							Item No.
„comfort“ grinding jars	12 ml	25 ml	50 ml	80 ml	125 ml	250 ml*	500 ml*
Hardened steel	-	-	01.462.0145	-	01.462.0144	01.462.0224	01.462.0229
Stainless steel	01.462.0239	01.462.0240	01.462.0149	-	01.462.0148	01.462.0223	01.462.0228
Tungsten carbide	-	-	01.462.0156	01.462.0267	01.462.0155	01.462.0222	-
Agate	-	-	01.462.0139	01.462.0197	01.462.0136	01.462.0220	01.462.0225
Sintered aluminum oxide	-	-	01.462.0153	-	01.462.0152	01.462.0221	01.462.0226
Zirconium oxide	-	-	01.462.0188	-	01.462.0187	01.462.0219	01.462.0227
*not for PM 200							
Accessories for „comfort“ grinding jars							Item No.
Adapter for stacking 50 ml „comfort“ grinding jars in the PM 100 or PM 400							
for 50 ml „comfort“ grinding jars made from hardened steel or stainless steel							03.025.0002
for 50 ml „comfort“ grinding jars made from tungsten carbide, agate, sintered aluminum oxide, zirconium oxide							03.025.0003
Aeration cover							
for 250 ml „comfort“ grinding jars made from stainless steel							22.107.0005
for 250 ml „comfort“ grinding jars made from tungsten carbide							22.107.0006
for 500 ml „comfort“ grinding jars made from stainless steel							22.107.0007
Safety closure devices							
for 50 ml „comfort“ grinding jars							22.867.0002
for 125 ml „comfort“ grinding jars							22.867.0003
for 250 ml „comfort“ grinding jars							22.867.0004
for 500 ml „comfort“ grinding jars							22.867.0005
Grinding balls							Item No.
Grinding balls	2 mm Ø*	3 mm Ø*	10 mm Ø	20 mm Ø	30 mm Ø	40 mm Ø	
Hardened steel	-	-	05.368.0059	05.368.0033	05.368.0057	05.368.0056	
Stainless steel	22.455.0010	22.455.0011	05.368.0063	05.368.0062	05.368.0061	05.368.0060	
Tungsten carbide	-	-	05.368.0071	05.368.0070	05.368.0069	05.368.0068	
Agate, polished	-	-	05.368.0067	05.368.0028	05.368.0065	05.368.0064	
Sintered aluminum oxide	-	-	05.368.0021	05.368.0054	05.368.0053	05.368.0052	
Zirconium oxide	05.368.0089	05.368.0090	05.368.0094	05.368.0093	05.368.0092	05.368.0091	
*Grinding balls for colloidal milling (container = 500 g)							

**Retsch**®

**Retsch GmbH**  
Rheinische Straße 36  
42781 Haan, Germany

Telephone +49 21 29 / 55 61 - 0  
Telefax +49 21 29 / 87 02

E-mail info@retschi.com  
Internet www.retschi.com

a VERDER company

RETSCH – Your specialist for sample preparation offers you a comprehensive range of equipment. Please request information on our crushers, mills, sieve shakers, sample dividers, feeders as well as cleaning and drying machines.