

DESCRIPTION

The Eclipse 705 Transmitter is a loop-powered, 24 V DC liquid-level transmitter based on the revolutionary Guided Wave Radar (GWR) technology. Encompassing a number of significant engineering accomplishments, this leading edge level transmitter is designed to provide measurement performance well beyond that of many traditional technologies, as well as “through-air” radars.

The innovative enclosure is a first in the industry, orienting dual compartments (wiring and electronics) in the same plane, and angled to maximize ease of wiring, configuration, set-up and data display.

This single transmitter can be used with all probe types and offers enhanced reliability, as demonstrated by a Safe Failure Fraction of 91 %.

FEATURES

- * “REAL LEVEL”, measurement not affected by media variables eg. dielectrics, pressure, density, pH, viscosity, ...
- * Easy bench configuration - no need for level simulation.
- * Two-wire, intrinsically safe loop powered level transmitter.
- * 20-point custom strapping table for volumetric output.
- * 360° rotatable housing can be dismantled without depressurizing the vessel via “Quick connect/disconnect” probe coupling.
- * Two-line, 8-character LCD and 3-button keypad.
- * Probe designs: up to +430 °C / 430 bar (+800 °F / 6250 psi).
- * Saturated steam applications up to 155 bar @ +345 °C (2250 psi @ +650 °F).
- * Cryogenic applications down to -196 °C (-320 °F).
- * Integral or remote electronics.
- * Suited for SIL 1/2 or SIL 2/3 Loops (full FMEDA report available).



APPLICATIONS

MEDIA: Liquids or slurries; hydrocarbons to water-based media (dielectric 1,4 - 100).

VESSELS: Most process or storage vessels up to rated probe temperature and pressure.

CONDITIONS: All level measurement and control applications including process conditions exhibiting visible vapors, foam, surface agitation, bubbling or boiling, high fill/empty rates, low level and varying dielectric media or specific gravity.

Ask for your free copy of the Eclipse® 705 performance report by WIB/Evaluation International (SIREP)/EXERA.

Measures real «LEVEL, VOLUME, INTERFACE»

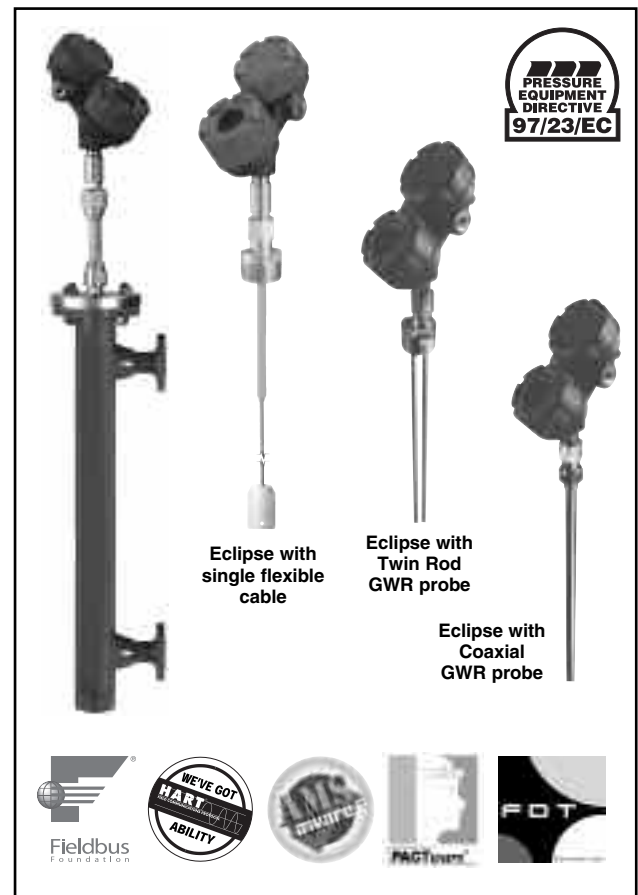

AGENCY APPROVALS

Agency	Approvals
ATEX Ex	II 3 (1) G EEx nA II T6, non sparking II 3 (1) G EEx nA [ia] IIC T6, FNICO – FF non incendive II 1 G EEx ia IIC T4, intrinsically safe II 1 G EEx ia IIC T4, FISCO – FF intrinsically safe II 1 / 2 G D EEx d[ia] IIC T6, explosion proof
Lloyds	Primary level safety device for steamdrums conform to - EN 12952-11 (water tube boilers) - EN 12953-9 (shell boilers)
TÜV	WHG § 19, overfill prevention
AIB	VLAREM II – 5.17.7
FM/CSA®	Non Incendive / Intrinsically safe / Explosion proof
LRS	Lloyds Register of Shipping (marine applications)
RosTECH/FSTS GOST-K/GGTN-K	Russian Authorisation Standards

① Probe is intrinsically safe to ATEX II 1 G EEx ia IIC T6 and can be used in zone 0, on flammable liquids.

TECHNOLOGY

Level

Eclipse® Guided Wave Radar is based upon the technology of TDR (Time Domain Reflectometry). TDR utilizes pulses of electromagnetic energy transmitted down a wave guide (probe). When a pulse reaches a liquid surface that has a higher dielectric constant than the air (ϵ_r of 1) in which it is traveling, the pulse is reflected. The travelling time of the pulse is measured via ultra speed timing circuitry that provides an accurate measure of the liquid level. Even after the pulse is reflected from the upper surface, some of the energy continues down the GWR probe through the upper liquid. The pulse is again reflected when it reaches the higher dielectric lower liquid, as shown in the illustration.

Interface

The Eclipse® 705, is capable of measuring both an upper liquid level and an interface liquid level. It is required that the upper liquid has a dielectric constant between 1.4 and 5, and the lower liquid has a dielectric constant greater than 15. A typical application would be oil over water, with the upper layer of oil being non-conductive ($\epsilon_r \pm 2,0$), and the lower layer of water being very conductive ($\epsilon_r \pm 80$). The thickness of the upper layer must be > 50 mm (2"). The maximum upper layer is limited to the length of the 7MT GWR probe, which is available in lengths up to 6,1 m (240").

Emulsion layers

As emulsion layers can decrease the strength of the reflected signal, the Eclipse® 705 should only be utilized in those interface applications that have clean, distinct layers. Contact the factory for application assistance.

Interface

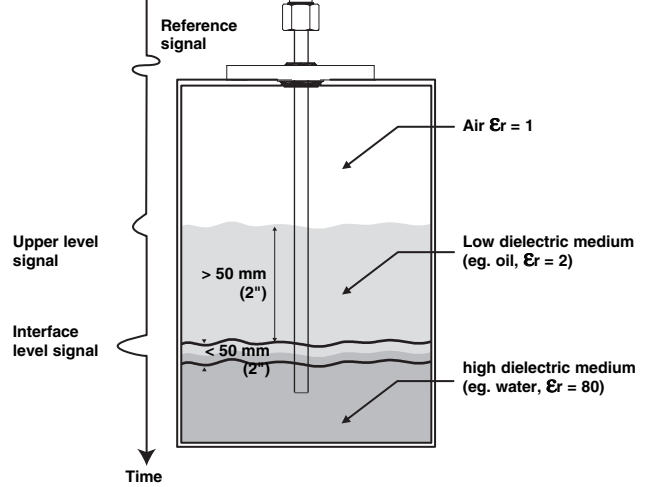

Level

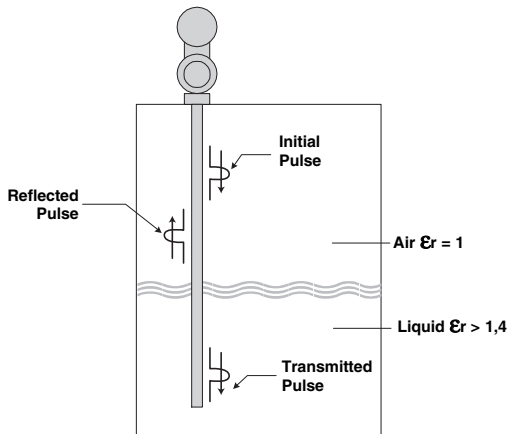

Single lead probe

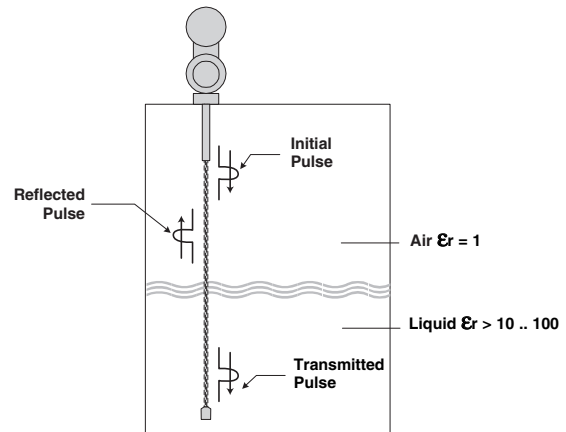

PACTware® PC SOFTWARE PROGRAM

PACTware PC software and the new Field Device Tool (FDT) standard take radar level measurement to a new level of setup efficiency and user-friendliness. The powerful Eclipse radar transmitter with its linear program has always been easy to use. PACTware builds on that ease of use by adding a graphical software interface. Simply connect your PC through the HART® loop and all functionality can be accessed quickly, conveniently, and safely.

Refer to PACTware bulletins 59-101 and 59-601 for more information.



REPLACEMENT OF DISPLACER TRANSMITTER

Eclipse® has proven to be the perfect replacement for existing torque tube transmitters. In hundreds of applications around the globe, customers have found Eclipse® Guided Wave Radar superior to torque tube transmitters:

- **Cost:**
A new Eclipse® costs only slightly more than rebuilding an aging torque tube.
- **Installation:**
No field calibration is necessary; it can be configured in minutes with no level movement. Pre-configuration from factory is free of charge.
- **Performance:**
Eclipse® is not affected by changes in specific gravity or dielectric.
- **Ease of replacement:**
Proprietary flanges are offered so existing chamber/ cages can be used.

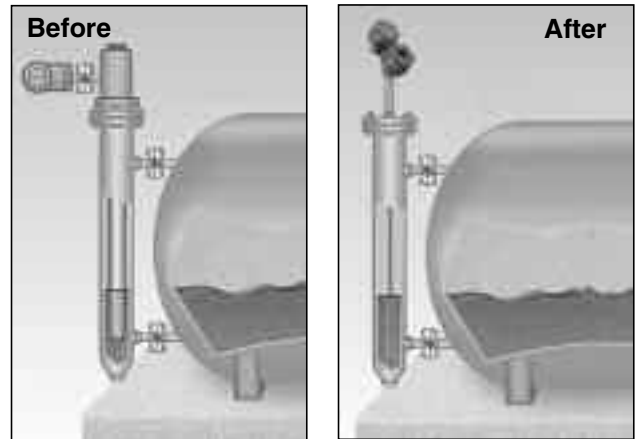

In order to match the proper Eclipse transmitter with the proper external cage, consider the following:

- **Type of application** – use the applicable GWR probe, see page 5.
- **Overfill proof:** Overfilling occurs when the level rises above the max level – radar based equipment may provide erroneous output in this zone unless an adapted design is used. GWR probes without top transition zone (7MR - 7MS - 7MD - 7MT) are always safe to use – only in cases where the application demands for a different probe type, other selections should be considered and the recommended precautions followed.
- **Min cage size:**
 - coaxial type: min 2"/DN 50
 - twin rod type: min 3"/DN 80
 - single rod type: consult factory.

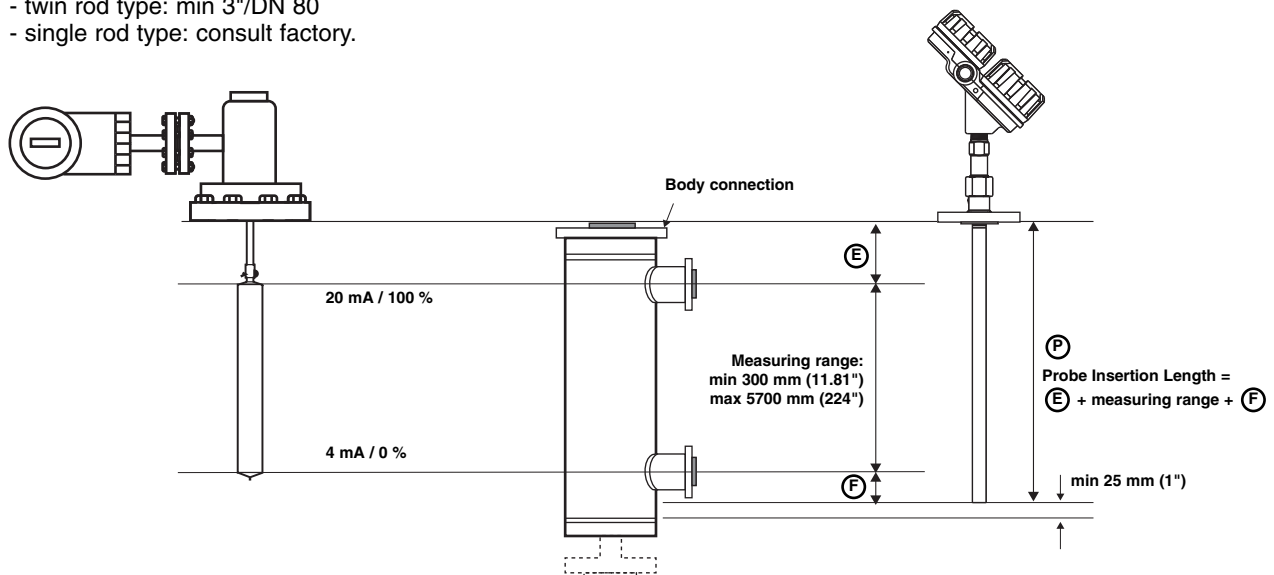

Indicative probe length for replacing displacer transmitters

Below table helps to define the GWR probe length based upon the length of the most common displacer transmitters. Consult the selection guide on the next page.

Manufacturer	Type	Process connection	Displacer length inches (mm)	Probe length ^① mm (inches)
Magnetrol®	EZ & PN Modulevel®	ANSI/DIN flange	≥ 14" (356)	Displacer + 178 (7)
Masoneilan®	Series 1200	Proprietary flange	≥ 14" (356)	Displacer + 203 (8)
		ANSI/DIN flange	≥ 16" (406)	Displacer + 203 (8)
Fisher® series 2300 & 2500	249B, 259B, 249C cages	Proprietary flange	≥ 14" (356)	Displacer + 254 (10)
	other cages	ANSI flange	≥ 14" (356)	consult factory
Eckhardt®	Series 134,144	ANSI/DIN flange	≥ 14" (356)	consult factory
Tokyo Keiso®	FST-3000	ANSI/DIN flange	H = 11.8" (300)	Displacer + 229 (9)
		ANSI/DIN flange	≥ H = 19.7" (500)	Displacer + 229 (9)

^① Round down resulting calculation to the nearest cm.

PROPRIETARY FLANGES

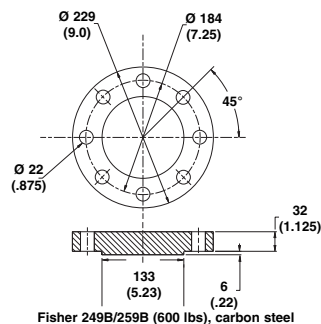

Figure 1

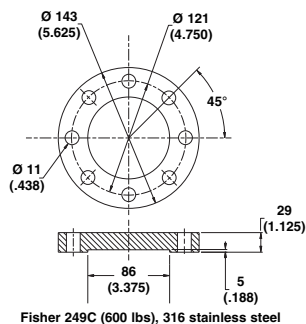

Figure 2

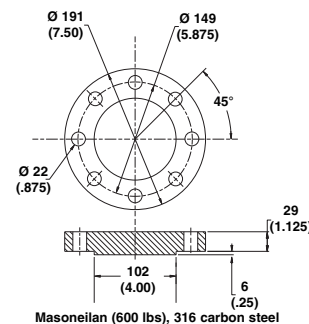

Figure 3

CAGES

Eclipse can be built into cages as small as DN 50 / 2". When a new cage is needed, it can be ordered together with the Eclipse. Magnetrol has a long tradition in offering cost effective cages. Magnetrol cages comply with PED regulations and are available with a wide variety of options.

Measuring span	30-610 cm (12-240") ^①
Materials of construction	Carbon steel or 316 (1.4401) stainless steel
Process connection sizes	3/4", 1", 1 1/2", 2"
Process connection ratings	150#-2500# ANSI
Configurations	Side-Side and Side-Bottom
Process pressures	Up to 430 bar (6250 psig) ^①
Process temperatures	Up to +430 °C (+800 °F) ^①

^① Limitations are defined per selected GWR probe.

For more details – consult bulletin 57-140.

AURORA™

Aurora® is the innovative combination of the Eclipse® Guided Wave Radar and a Magnetic Level Indicator (MLI). The MLI indicator rail offers the Eclipse a highly visible level indication that may obsolete the need for local indicators. The integration of these two independent technologies provides an excellent redundancy in one integrated design. With Aurora® it is even possible to plan maintenance ahead. Maintenance becomes needed when build up in an installation has surpassed the allowable limit. Build up on the float inside the MLI cage will force it to sink deeper in the liquid while the measurement of the Eclipse will not see any build up until its both lead elements are completely clogged. In this way, the float will indicate a lower level versus the real level measured by the Eclipse. The degree of deviation between both read outs is a worthwhile tool to determine the real need for maintenance.

For more details – consult bulletin 57-138.

REPLACEMENT OF TOP/BOTTOM CAGES

In addition to Magnetrol's Torque Tube Cage Flange options, the Eclipse® 705 transmitter and 7EK GWR probe/cage can also be used in replacing existing Top/Bottom and Top/Side torque tube installations. After removal of the existing torque tube cage assembly (controller, displacer and cage), Eclipse Guided Wave Radar may then be installed directly in its place. Several models are available for some of the major torque tube displacer transmitter manufacturers. Because the Model 7EK probe/cage mounting dimensions and measuring ranges match the original manufacturer's specification, no re-piping is necessary.



SELECTION GUIDE

COAXIAL TYPE GWR PROBE



signal propagation

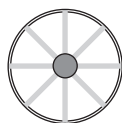

end view

TWIN ROD/CABLE TYPE GWR PROBE



signal propagation



end view

SINGLE ROD/CABLE TYPE



signal propagation

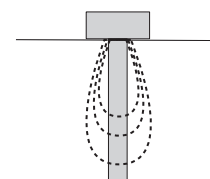

Application	Dielectric limit	Temperature limits	Pressure	Applications			GWR Probe
				Vacuum ①	Overfill proof	Foam ②	

COAXIAL TYPE GWR probes - max viscosity 500 cP (I.D. 3/4") – 1500 cP (I.D. 1 3/4")

Overfill safe	ϵ_r 1,4 - 100	-40 °C up to +200 °C	max 70 bar	Yes	Yes	No	7MR
Standard level	ϵ_r 1,4 - 100	-40 °C up to +150 °C	max 70 bar	Yes	Yes ^⑤	No	7MA
High temp / High pressure Interface	ϵ_r 1,4 - 100 ^③	-196 °C up to +430 °C	max 430 bar	Full	Yes	No	7MD
Saturated steam	ϵ_r 10 - 100	up to +345 °C	max 155 bar	Yes	Yes	No	7MS
Interface	ϵ_r 1,4 - 100	-40 °C up to +200 °C	max 70 bar	Yes	Yes	No	7MT

Twin rod/cable GWR probes - max 1500 cP

Liquids - rod	ϵ_r 1,9 - 100	-40 °C up to +150 °C	max 50 bar	Yes	No	Yes	7MB
Liquids - cable	ϵ_r 1,9 - 100	-40 °C up to +150 °C	max 50 bar	Yes	No	No	7M7
Solids - cable	ϵ_r 1,9 - 100	Ambient	Atmospheric	Yes	No	NA	7M5

Single rod/cable GWR probes - max 10.000 cP

Liquids - rod	ϵ_r 1,9 - 100 ^④	-40 °C up to +150 °C	max 70 bar	Yes	No	Yes	7MF
Liquids - cable	ϵ_r 1,9 - 100 ^④	-40 °C up to +150 °C	max 70 bar	Yes	No	Yes	7M1
Solids - cable	ϵ_r 4 - 100	Ambient	Atmospheric	Yes	No	NA	7M2
High temp / high pressure	ϵ_r 1,9 - 100 ^④	-40 °C up to +315 °C	max 207 bar	Yes	No	Yes	7MJ
Sanitary	ϵ_r 1,9 - 100 ^④	-40 °C up to +150 °C	max 5 bar	Yes	No	Yes	7MF-E
Top/bottom	ϵ_r 1,4 - 100	-15 °C up to +320 °C	max 205 bar	Yes	Yes	Yes	7EK

① Each Eclipse probe can be used for vacuum service (negative pressure) but only the Borosilicate GWR probes (7MD) are suited for full vacuum conditions (Helium leak < 10⁻⁸ cc/s @ 1 bar abs.)

② Eclipse is ideally suited to be used on foaming applications but in specific conditions where dense foam can enter/hydrate in the stilling well, coaxial GWR probes are not recommended.

③ Depending spacer material. See model selection 7MD GWR probe.

④ For media with ϵ_r 1,9 up to 10, GWR probe must be mounted in between 75 mm and 150 mm (3"-6") away from the metal tank wall or in a metal cage / stillwell.

⑤ 7MA probe is not recommended in overfill applications requiring accuracy up to the process connection.

DIMENSIONS in mm (inches)

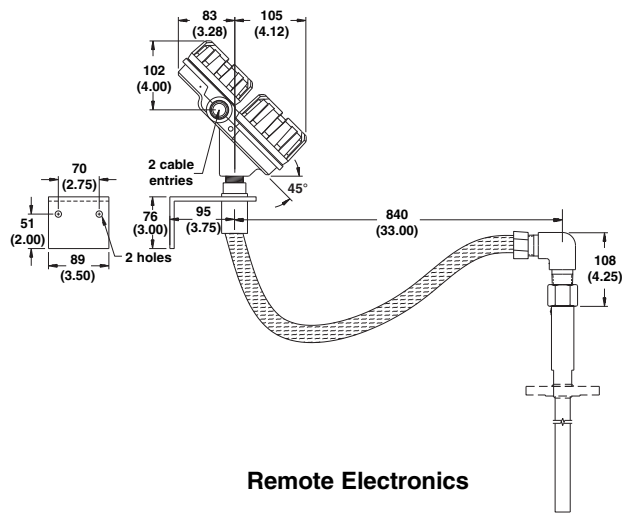
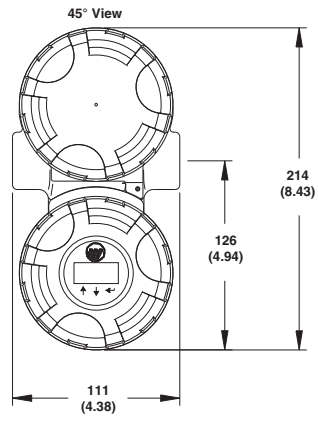
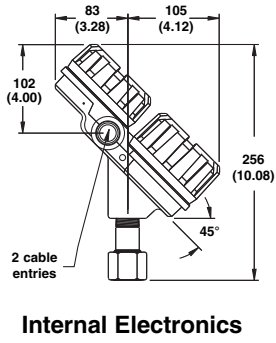

ELECTRICAL WIRING

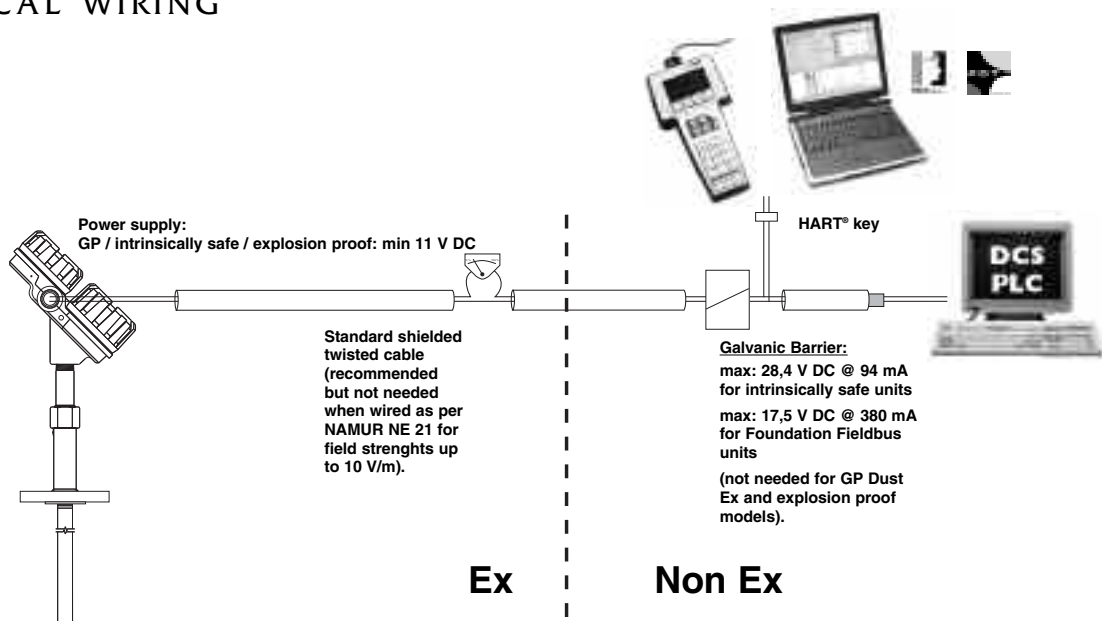

EXPEDITE SHIP PLAN (ESP)

Several Eclipse Guided Wave Radar Transmitters are available for quick shipment, within max. 3 weeks after factory receipt of purchase order, through the Expedite Ship Plan (ESP).

Models covered by ESP service are conveniently colour coded in the selection data charts.

To take advantage of ESP, simply match the colour coded model number codes (standard dimensions apply).

ESP service may not apply to orders of ten units or more. Contact your local representative for lead times on larger volume orders, as well as other products and options.

SELECTION DATA

A complete measuring system consists of:

1. Eclipse transmitter head/electronics
2. Eclipse 705 GWR probe
3. OPTION: Eclipse DTM (PACTWARE®) - order code: **070-3001-001**
4. OPTION:
 - TFE spacer for single rod metal GWR probes; order code: **089-9114-001** (7MF-A), **089-9114-002** (7MF-B), **089-9114-003** (7MF-C)
 - PEEK spacer for single rod 7MJ GWR probe; order code: **089-9114-005** (7MJ-A), **089-9114-006** (7MJ-B), **089-9114-007** (7MJ-C)
 - Additional weight for 7M1 GWR probe; order code: **089-9120-001**
 - Additional weight for 7M7 GWR probe; order code: **089-9121-001**
 - Additional weight for 7M2 GWR probe; order code: **004-8778-001** (requires 2 x **010-1731-001**: cable clamps)
 - Additional weight for 7M5 GWR probe; order code: **004-8778-002** (requires 2 x **010-1731-001**: cable clamps)
5. OPTION: HART® communicator: for more details, consult factory

1. Order code for ECLIPSE 705 transmitter head/electronics

BASIC MODEL NUMBER

7	0	5	Eclipse 705 guided wave radar transmitter
---	---	---	---

POWER

5	24 V DC, two wire loop powered
---	--------------------------------

SIGNAL OUTPUT AND ELECTRONICS

1	0	4-20 mA with Hart – standard electronics (SFF of 85.4%)
1	A	4-20 mA with Hart – SIL enhanced electronics (SFF of 91%)
2	0	Fieldbus communication

ACCESSORIES

A	Digital display and keypad
0	Blind transmitter (no display/keypad)

MOUNTING/CLASSIFICATION (Consult factory for FM/CSA approvals)

1	Integral, General Purpose (& I.S. FM/CSA)
2	Remote, General Purpose (& I.S. FM/CSA)
A	Integral, ATEX II 1 G EEx ia IIC T4 – FISCO ATEX, intrinsically safe for units with Fieldbus Foundation
B	Remote, ATEX II 1 G EEx ia IIC T4 – FISCO ATEX, intrinsically safe for units with Fieldbus Foundation
C	Integral, ATEX II 1/2 G D EEx d[ia] IIC T6 T85 °C
D	Remote, ATEX II 1/2 G D EEx d[ia] IIC T6 T85 °C
E	Integral, ATEX II 3 (1) G EEx nA II T6, non sparking Integral, ATEX II 3 (1) G EEx nA [ia] IIC T6, FNICO – FF non incendive
F	Remote, ATEX II 3 (1) G EEx nA II T6, non sparking Remote, ATEX II 3 (1) G EEx nA [ia] IIC T6, FNICO – FF non incendive

MATERIAL OF CONSTRUCTION

1	Cast aluminium dual compartment housing
2	Stainless steel dual compartment housing

CABLE ENTRY

1	M20 x 1.5 (2 entries - one plugged)
0	3/4" NPT (2 entries - one plugged)

7	0	5	5				
---	---	---	---	--	--	--	--

complete order code for ECLIPSE 705 transmitter head/electronics

MOUNTING

Use:
7MA or 7MR or 7MT

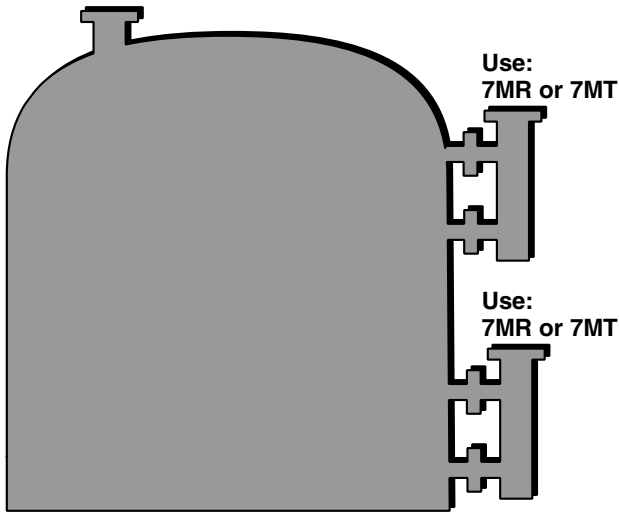

High level shutdown / Overfill protection

Special consideration is necessary in any application where guided wave radar is to be used for high level shutdown / overfill protection. To ensure proper measurement, the guided wave radar probe should be installed so the maximum overfill level is a minimum of 150 mm (6") below the process connection. This may include utilizing a nozzle or spool piece to raise the probe. No special precautions are required for the 7MR probe. Consult factory for further information.

DIMENSIONS in mm (inches)

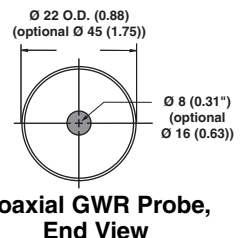
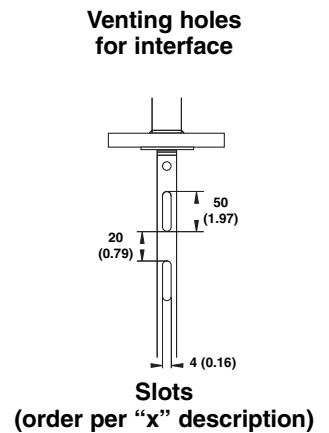
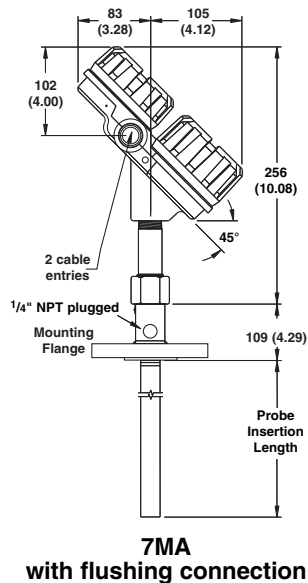
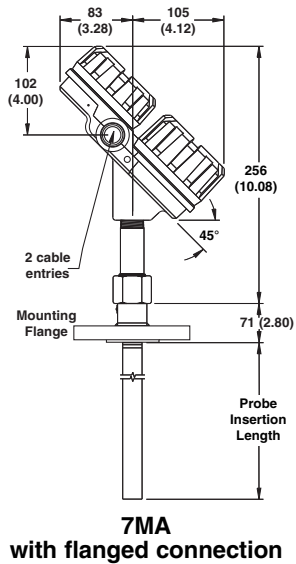
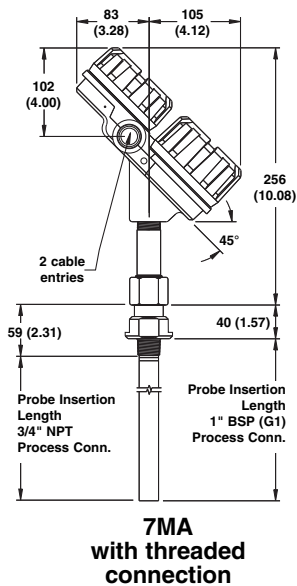
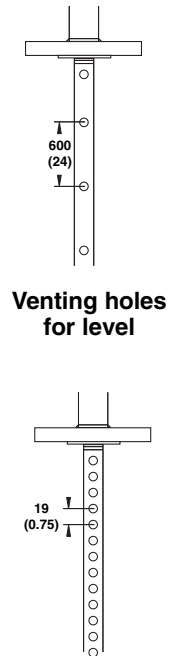
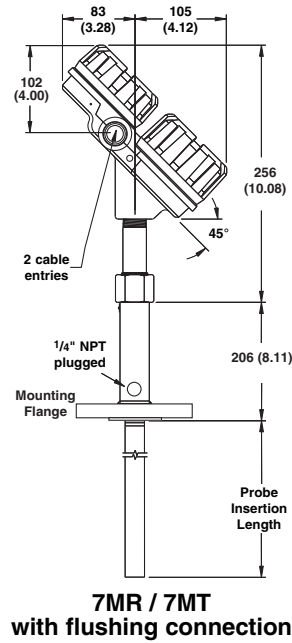
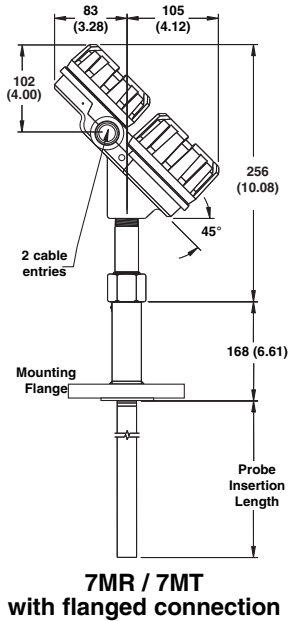
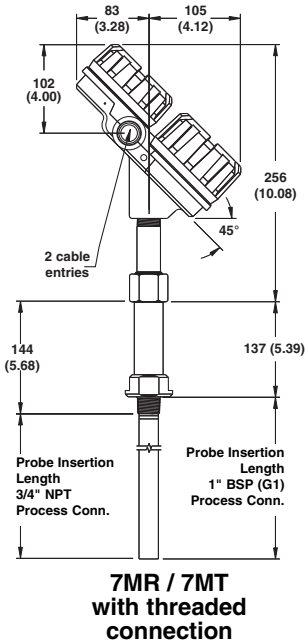

2. Order code for ECLIPSE 705 Coaxial GWR probe

BASIC MODEL NUMBER

GWR probe suited for external cage and/or in-tank mounting

7 M R	Overflow safe Coaxial GWR probe for level	(dielectric range: ≥ 1,4) - WHG approved
7 M A	Standard Coaxial GWR probe for level ^①	(dielectric range: ≥ 1,4)
7 M T	Overflow safe Coaxial GWR probe for interface	(dielectric upper liquid: ≥ 1,4 and ≤ 5 / lower liquid ≥ 15)

^① 7MA probes should not be used in overflow applications requiring accuracy up to the process connection)

MATERIAL OF CONSTRUCTION - wetted parts (including process connection flange when applicable)

**Standard coaxial GWR probe: Ø 22 mm
min. dielectrics ≥ 1.4**

**Enlarged coaxial GWR probe: Ø 45 mm – min 3" /
DN 80 process connection – min. dielectrics ≥ 1.4**

A	316/316L (1.4401/1.4404) stainless steel with Teflon [®] spacers
B	Hastelloy C (2.4819)
C	Monel (2.4360)

N	316/316L (1.4401/1.4404) stainless steel with Teflon [®] spacers
P	Hastelloy C (2.4819)
R	Monel (2.4360)

PROCESS CONNECTION - SIZE/TYPE (consult factory for other process connections)

Use min 3" / DN 80 process connection for enlarged coaxial GWR probe.

Threaded

1 1	3/4" NPT thread
-----	-----------------

2 2	1" BSP (G1) thread
-----	--------------------

ANSI flanges

2 3	1"	150 lbs. ANSI RF
2 4	1"	300 lbs. ANSI RF
2 5	1"	600 lbs. ANSI RF
3 3	1 1/2"	150 lbs. ANSI RF
3 4	1 1/2"	300 lbs. ANSI RF
3 5	1 1/2"	600 lbs. ANSI RF
4 3	2"	150 lbs. ANSI RF
4 4	2"	300 lbs. ANSI RF

4 5	2"	600 lbs. ANSI RF
5 3	3"	150 lbs. ANSI RF
5 4	3"	300 lbs. ANSI RF
5 5	3"	600 lbs. ANSI RF
6 3	4"	150 lbs. ANSI RF
6 4	4"	300 lbs. ANSI RF
6 5	4"	600 lbs. ANSI RF

EN/DIN flanges

B A	DN 25, PN 16	EN 1092-1 Type A
B B	DN 25, PN 25/40	EN 1092-1 Type A
B C	DN 25, PN 63/100	EN 1092-1 Type B2
C A	DN 40, PN 16	EN 1092-1 Type A
C B	DN 40, PN 25/40	EN 1092-1 Type A
C C	DN 40, PN 63/100	EN 1092-1 Type B2
D A	DN 50, PN 16	EN 1092-1 Type A
D B	DN 50, PN 25/40	EN 1092-1 Type A
D D	DN 50, PN 63	EN 1092-1 Type B2

D E	DN 50, PN 100	EN 1092-1 Type B2
E A	DN 80, PN 16	EN 1092-1 Type A
E B	DN 80, PN 25/40	EN 1092-1 Type A
E D	DN 80, PN 63	EN 1092-1 Type B2
E E	DN 80, PN 100	EN 1092-1 Type B2
F A	DN 100, PN 16	EN 1092-1 Type A
F B	DN 100, PN 25/40	EN 1092-1 Type A
F D	DN 100, PN 63	EN 1092-1 Type B2
F E	DN 100, PN 100	EN 1092-1 Type B2

Torque tube mating flanges ^①

T T	600 lbs Fisher (249B/259B) in carbon steel - as per dimensions of Figure 1 on page 4
T U	600 lbs Fisher (249C) in stainless steel - as per dimensions of Figure 2 on page 4
U T	600 lbs Masoneilan flange in carbon steel - as per dimensions of Figure 3 on page 4
U U	600 lbs Masoneilan flange in stainless steel - as per dimensions of Figure 3 on page 4

^① Always check dimensions if no ANSI/DIN flanges are used.

PROCESS SEAL - MATERIAL ^②

0	Viton GFLT seal - for universal use	-40 °C (-40 °F) / +200 °C (+400 °F)
1	EPDM (Ethylene Propylene) - for e.g. caustic soda applications	-50 °C (-60 °F) / +125 °C (+250 °F)
2	Kalrez 4079 seal - for aggressive media ^③	-40 °C (-40 °F) / +200 °C (+400 °F)
8	Aegis PF 128 seal – for steam and NACE applications	-20 °C (-4 °F) / +200 °C (+400 °F)

^② Consult factory for alternative seal materials.

^③ For ammonia/chlorine applications use the 7MD GWR probe.

INSERTION LENGTH – specify per 1 cm (0.39") increments

0 6 0	min 60 cm (24") insertion length
6 1 0	max 610 cm (240") insertion length

Note: for 7MR/7MT, consult factory for insertion lengths < 60 cm (24")

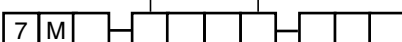

complete code for ECLIPSE 705 Coaxial GWR probe

MOUNTING

Use:
7MB GWR probe only for in-tank mounting

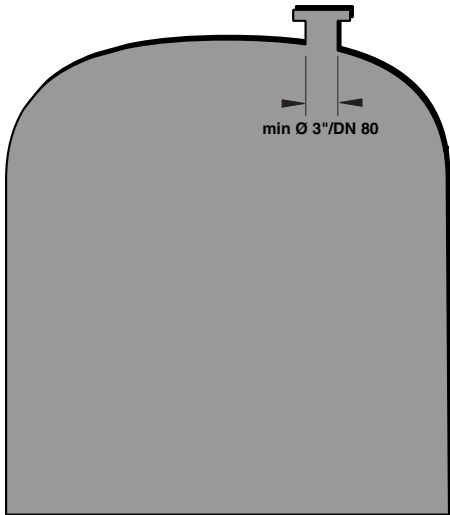

High level shutdown / Overfill protection

Special consideration is necessary in any application where guided wave radar is to be used for high level shutdown / overfill protection. To ensure proper measurement, the guided wave radar probe should be installed so the maximum overfill level is a minimum of 150 mm (6") below the process connection. This may include utilizing a nozzle or spool piece to raise the probe. Consult factory for further information.

DIMENSIONS in mm (inches)

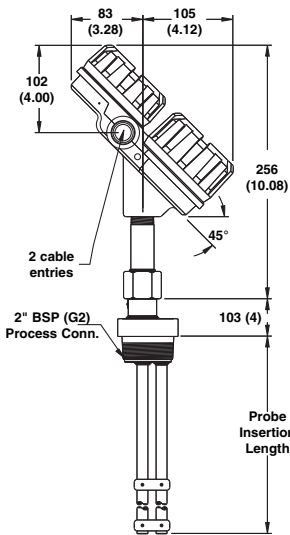

7MB
with threaded
2" BSP (G2)
connection

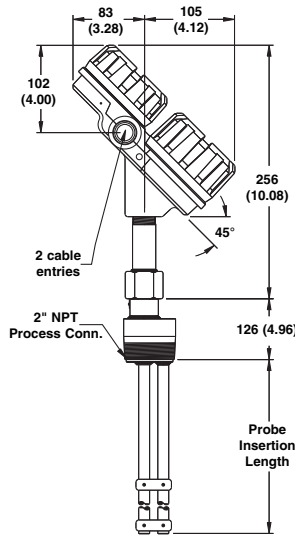

7MB
with threaded
2" NPT
connection

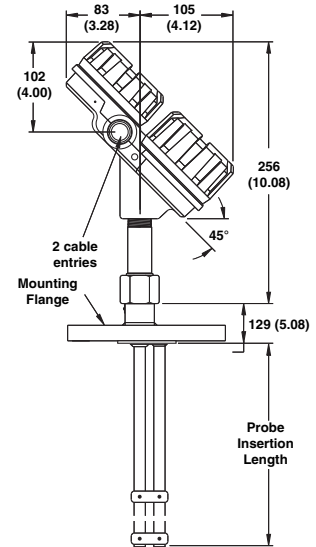

7MB
with flanged
connection

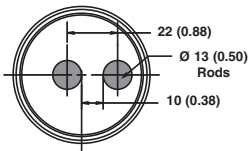

Twin Rod GWR Probe,
End View

2. Order code for ECLIPSE 705 Twin Rod GWR probe

BASIC MODEL NUMBER

GWR probe for in-tank mounting only

7 M B	Twin Rod GWR probe for Eclipse transmitter	(dielectric range: $\geq 1,9$) - WHG approved
-------	--	--

MATERIAL OF CONSTRUCTION - wetted parts (including process connection flange when applicable)

A	316/316L (1.4401/1.4404) stainless steel with TFE spacers
B	Hastelloy C (2.4819) with TFE spacers
C	Monel (2.4360) with TFE spacers

PROCESS CONNECTION - SIZE/TYPE

Threaded

4 1	2" NPT thread
4 2	2" BSP (G2) thread

ANSI flanges (consult factory for 2" process connections)

5 3	3" 150 lbs. ANSI raised face flange
5 4	3" 300 lbs. ANSI raised face flange
6 3	4" 150 lbs. ANSI raised face flange
6 4	4" 300 lbs. ANSI raised face flange

EN/DIN flanges (consult factory for DN 50 process connections)

E A	DN 80, PN 16	EN 1092-1 Type A
E B	DN 80, PN 25/40	EN 1092-1 Type A
E D	DN 80, PN 63	EN 1092-1 Type B2
F A	DN 100, PN 16	EN 1092-1 Type A
F B	DN 100, PN 25/40	EN 1092-1 Type A
F D	DN 100, PN 63	EN 1092-1 Type B2

Torque tube mating flanges ^①

T T	600 lbs Fisher (249B/259B) in carbon steel - as per dimensions of Figure 1 on page 4
T U	600 lbs Fisher (249C) in stainless steel - as per dimensions of Figure 2 on page 4
U T	600 lbs Masoneilan flange in carbon steel - as per dimensions of Figure 3 on page 4
U U	600 lbs Masoneilan flange in stainless steel - as per dimensions of Figure 3 on page 4

^① Always check dimensions if no ANSI/DIN flanges are used.

PROCESS SEAL - MATERIAL ^②

0	Viton GFLT seal - for universal use	-40 °C (-40 °F) / +200 °C (+400 °F)
1	EPDM (Ethylene Propylene) - for e.g. caustic soda applications	-50 °C (-60 °F) / +125 °C (+250 °F)
2	Kalrez 4079 seal - for aggressive media ^③	-40 °C (-40 °F) / +200 °C (+400 °F)
8	Aegis PF 128 seal - for steam and NACE applications	-20 °C (-4 °F) / +200 °C (+400 °F)

^② Consult factory for alternative seal materials.

^③ For ammonia/chlorine applications use the 7MD GWR probe.

INSERTION LENGTH – specify per 1 cm (0.39") increments (up to 22 m (75') with twin cable GWR probe, see page 18 and 19)

0 6 0	min 60 cm (24") insertion length
6 1 0	max 610 cm (240") insertion length

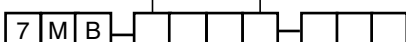

complete order code for ECLIPSE 705 Twin Rod GWR probe

MOUNTING

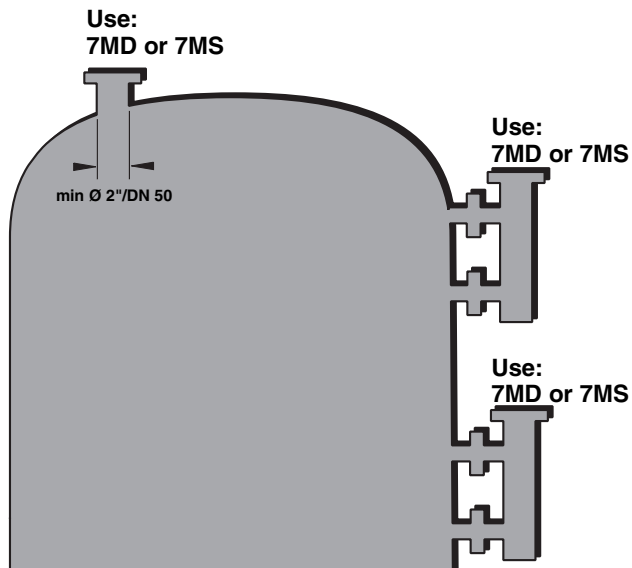

High level shutdown / Overfill protection

Special consideration is necessary in any application where guided wave radar is to be used for high level shutdown / overfill protection. To ensure proper measurement, the guided wave radar probe should be installed so the maximum overfill level is a minimum of 150 mm (6") below the process connection. This may include utilizing a nozzle or spool piece to raise the probe. No special precautions are required for the 7MD/7MS probe. Consult factory for further information.

DIMENSIONS in mm (inches)

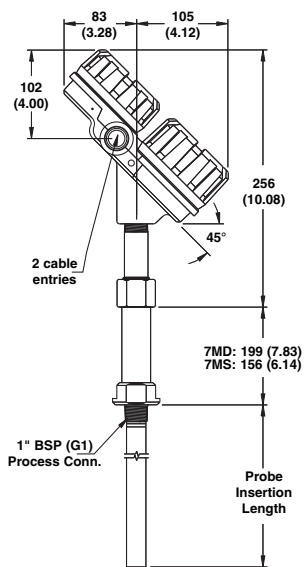

7MD/7MS with threaded 1" (G1) connection

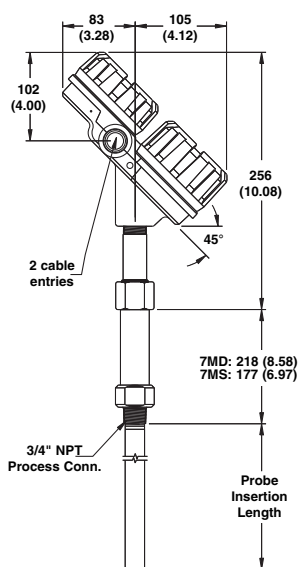

7MD/7MS with threaded 3/4" NPT Connection

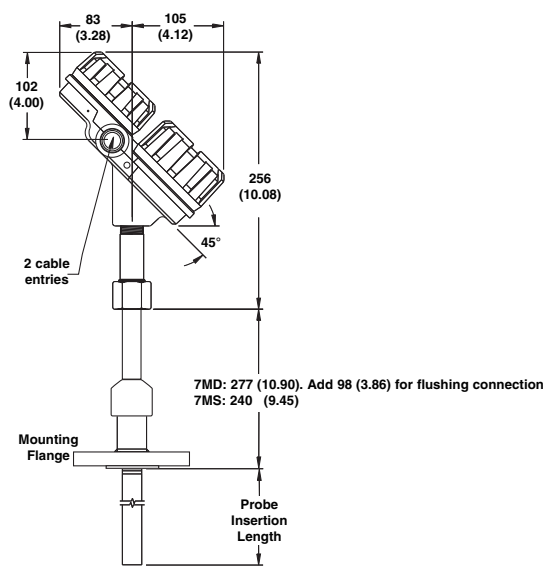

7MD/7MS with flanged connection

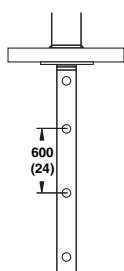

Venting holes for level

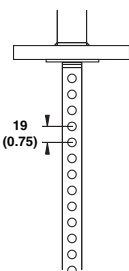

Venting holes for interface

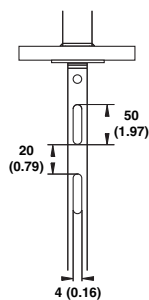

Slots (order per "x" description)

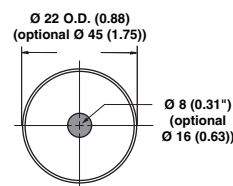

Coaxial GWR Probe, End View

2. Order code for ECLIPSE 705 High Temperature / High Pressure Coaxial GWR probe

BASIC MODEL NUMBER

7 M D	High Temp / High Pressure (HTHP) Coaxial GWR probe	overflow safe / WHG approved ^①
7 M S	Saturated steam – Coaxial GWR probe	overflow safe / Stoomwezen approved

^① For HTHP interface applications, specify "X7MD": X = 7MD for interface use with multiple venting holes.

MATERIAL OF CONSTRUCTION (all wetted parts) AND MIN. DIELECTRICS

For 7MD GWR probes – max 430 bar (6250 psig) – Standard coaxial GWR probe: Ø 22mm

A	316/316L (1.4401/1.4404) SST with ceramic spacers	min. dielectrics: ≥ 2,0 / max +430 °C
B	Hastelloy C (2.4819) with ceramic spacers	min. dielectrics: ≥ 2,0 / max +430 °C
C	Monel (2.4360) with ceramic spacers	min. dielectrics: ≥ 2,0 / max +430 °C
V	316/316L (1.4401/1.4404) SST with H. Temp PEEK® spacers	min. dielectrics: ≥ 1,7 / max +345 °C
W	316/316L (1.4401/1.4404) stainless steel with Teflon® spacers	min. dielectrics: ≥ 1,4 / max +200 °C

For 7MD GWR probes – max 430 bar (6250 psig) – Enlarged coaxial GWR probe: Ø 45 mm – min 3" / DN 80 process connection

N	316/316L (1.4401/1.4404) SST with H. Temp PEEK® spacers	min. dielectrics: ≥ 1,7 / max +345 °C
P	Hastelloy C (2.4819) with H. Temp PEEK® spacers	min. dielectrics: ≥ 1,7 / max +345 °C
R	Monel (2.4360) with H. Temp PEEK® spacers	min. dielectrics: ≥ 1,7 / max +345 °C

For 7MS GWR probes – max 155 bar (2250 psig)

A	316/316L (1.4401/1.4404) stainless steel	min. dielectrics: ≥ 10 / max +345 °C
---	--	--------------------------------------

PROCESS CONNECTION - SIZE/TYPE (consult factory for other process connections)
Use min 3" / DN 80 process connection for enlarged coaxial GWR probes.

Threaded

1 1	3/4" NPT thread
-----	-----------------

2 2	1" BSP (G1) thread
-----	--------------------

ANSI flanges

2 3	1" 150 lbs. ANSI RF
2 4	1" 300 lbs. ANSI RF
2 5	1" 600 lbs. ANSI RF
2 K	1" 600 lbs. ANSI RJ
2 L	1" 900 lbs. ANSI RJ
3 3	1 1/2" 150 lbs. ANSI RF
3 4	1 1/2" 300 lbs. ANSI RF
3 5	1 1/2" 600 lbs. ANSI RF
3 K	1 1/2" 600 lbs. ANSI RJ
3 M	1 1/2" 900/1500 lbs. ANSI RJ
3 N	1 1/2" 2500 lbs. ANSI RJ
4 3	2" 150 lbs. ANSI RF
4 4	2" 300 lbs. ANSI RF
4 5	2" 600 lbs. ANSI RF
4 K	2" 600 lbs. ANSI RJ
4 M	2" 900/1500 lbs. ANSI RJ

4 N	2" 2500 lbs. ANSI RJ
5 3	3" 150 lbs. ANSI RF
5 4	3" 300 lbs. ANSI RF
5 5	3" 600 lbs. ANSI RF
5 K	3" 600 lbs. ANSI RJ
5 L	3" 900 lbs. ANSI RJ
5 M	3" 1500 lbs. ANSI RJ
5 N	3" 2500 lbs. ANSI RJ
6 3	4" 150 lbs. ANSI RF
6 4	4" 300 lbs. ANSI RF
6 5	4" 600 lbs. ANSI RF
6 K	4" 600 lbs. ANSI RJ
6 L	4" 900 lbs. ANSI RJ
6 M	4" 1500 lbs. ANSI RJ
6 N	4" 2500 lbs. ANSI RJ

EN/DIN flanges

B A	DN 25, PN 16	EN 1092-1 Type A
B B	DN 25, PN 25/40	EN 1092-1 Type A
B C	DN 25, PN 63/100	EN 1092-1 Type B2
B F	DN 25, PN 160	DIN 2527 form E
C A	DN 40, PN 16	EN 1092-1 Type A
C B	DN 40, PN 25/40	EN 1092-1 Type A
C C	DN 40, PN 63/100	EN 1092-1 Type B2
C F	DN 40, PN 160	DIN 2527 form E
C G	DN 40, PN 250	DIN 2527 form E
C H	DN 40, PN 320	DIN 2527 form E
C J	DN 40, PN 400	DIN 2527 form E
D A	DN 50, PN 16	EN 1092-1 Type A
D B	DN 50, PN 25/40	EN 1092-1 Type A
D D	DN 50, PN 63	EN 1092-1 Type B2
D E	DN 50, PN 100	EN 1092-1 Type B2
D F	DN 50, PN 160	DIN 2527 form E
D G	DN 50, PN 250	DIN 2527 form E
D H	DN 50, PN 320	DIN 2527 form E

D J	DN 50, PN 400	DIN 2527 form E
E A	DN 80, PN 16	EN 1092-1 Type A
E B	DN 80, PN 25/40	EN 1092-1 Type A
E D	DN 80, PN 63	EN 1092-1 Type B2
E E	DN 80, PN 100	EN 1092-1 Type B2
E F	DN 80, PN 160	DIN 2527 form E
E G	DN 80, PN 250	DIN 2527 form E
E H	DN 80, PN 320	DIN 2527 form E
E J	DN 80, PN 400	DIN 2527 form E
F A	DN 100, PN 16	EN 1092-1 Type A
F B	DN 100, PN 25/40	EN 1092-1 Type A
F D	DN 100, PN 63	EN 1092-1 Type B2
F E	DN 100, PN 100	EN 1092-1 Type B2
F F	DN 100, PN 160	DIN 2527 form E
F G	DN 100, PN 250	DIN 2527 form E
F H	DN 100, PN 320	DIN 2527 form E
F J	DN 100, PN 400	DIN 2527 form E

Torque tube mating flanges (always check dimensions if no ANSI / EN/DIN flanges are used)

T T	600 lbs Fisher (249B/259B) in carbon steel ^①
T U	600 lbs Fisher (249C) in stainless steel ^①

U T	600 lbs Masoneilan flange in carbon steel ^①
U U	600 lbs Masoneilan flange in stainless steel ^①

^① As per dimensions on page 4.

PROCESS SEAL MATERIAL

N	Borosilicate seal – for non steam applications (7MD)	-196 °C (-320 °F) / +400 °C (+750 °F) ^①
8	PEEK seal – for saturated steam applications (7MS)	-15 °C (0 °F) / +345 °C (+650 °F)

^① 7MD-W: max +200 °C (+400 °F) – 7MD-V: max +345 °C (+650 °F)

INSERTION LENGTH – specify per 1 cm (0.39") increments

0 6 0	min 60 cm (24") insertion length	– for 7MS/7MD
4 5 0	max 450 cm (177") insertion length	– for 7MS
6 1 0	max 610 cm (240") insertion length	– for 7MD

Note: for 7MD, consult factory for insertion lengths < 60 cm (24")

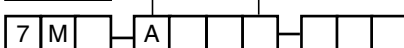

complete order code for ECLIPSE 705 High Temperature / High Pressure Coaxial GWR probe

2. Order code for Eclipse® 705 Top/Bottom GWR probe and cage

In order to re-assure that no incorrect dimensions are provided, please specify with your order the following dimensions (see drawings at bottom of page):

- Dimension A: top of process connection up to 20 mA range
- Dimension B: bottom of process connection up to 4 mA range
- Level Range, if different from 356 mm (14")

Order code for modified models or adders: put an "X" in front of the closest matching order code and specify the modifications/adders separately.

e.g: X7EK-K33A-010

X = measuring range of 500 mm.

BASIC MODEL NUMBER

GWR probe suited for in-line external cage mounting

7	E	K	Top/Bottom GWR probe and cage
---	---	---	-------------------------------

MATERIAL OF CONSTRUCTION - wetted parts (including process connection flange when applicable)

	Cage and Flanges	GWR probe
K	316/316L (1.4401/1.4404)	316/316L (1.4401/1.4404)
M	Carbon steel	

PROCESS CONNECTION - SIZE/TYPE

Threaded

3	1	1 1/2" NPT thread
4	1	2" NPT thread

Welded

3	9	1 1/2" socket weld
4	9	2" socket weld

ANSI flanges

3	3	1 1/2"	150 lbs. ANSI raised face flange
3	4	1 1/2"	300 lbs. ANSI raised face flange
3	5	1 1/2"	600 lbs. ANSI raised face flange
4	3	2"	150 lbs. ANSI raised face flange
4	4	2"	300 lbs. ANSI raised face flange
4	5	2"	600 lbs. ANSI raised face flange

LEVEL RANGE

A	356 mm (14")
---	--------------

OPTIONS

0	None
2	Sight glass connections (sight glass not included)

LIQUID TYPE / OPERATING TEMPERATURE

1	0	Conductive liquids (min Er ≥ 10)	max +320 °C (+605 °F)
2	0	All liquids (min Er ≥ 1.4)	max +260 °C (+500 °F)

7	E	K		A	0
---	---	---	--	---	---

complete order code for ECLIPSE 705 with Top/Bottom GWR probe and cage

DIMENSIONS in mm (inches)

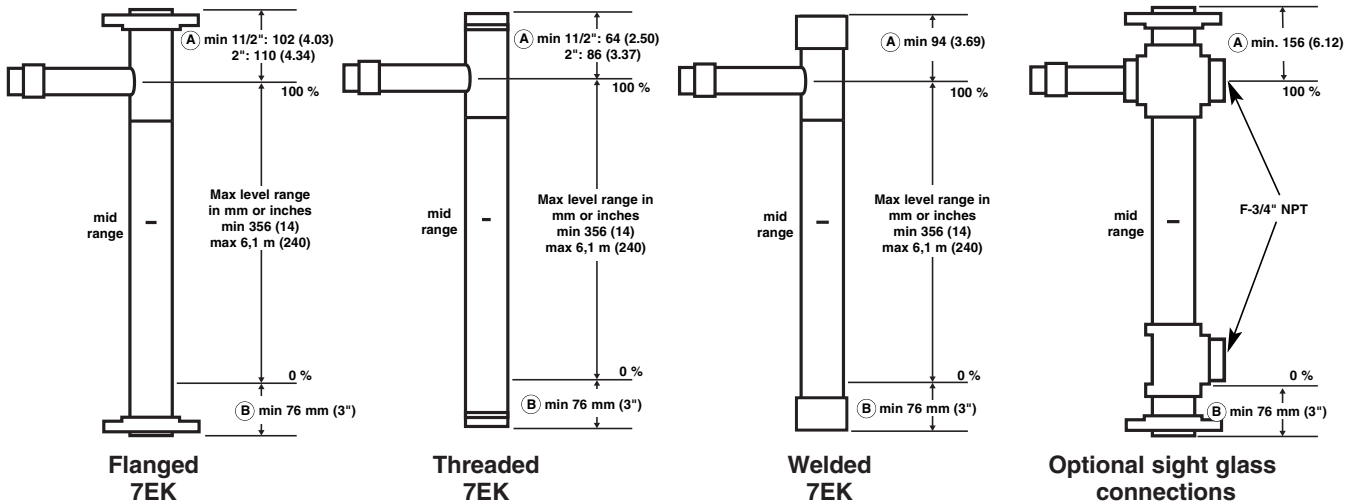

MOUNTING CONSIDERATIONS FOR SINGLE ROD GWR PROBES

1. Turbulence

For 7MF/7M1/7M2/7MJ

The bottom of the probe should be stabilized if turbulence will cause a deflection of more than 75 mm at 3 m (3" at 10') of length. The probe should not make contact with a metal tank. A TFE bottom spacer for 7MF GWR probes or PEEK spacer for 7MJ is optional.

2. Nozzles: do not restrict the performance by ensuring the following:

For 7MF/7M1/7M2/7MJ (single rod/cable):

1. Nozzle must be 50 mm (2") or larger diameter.
2. Nozzle inside diameter (**A**) should be \geq to nozzle height (**B**). If this is not the case, it is recommended to adjust BLOCKING DISTANCE and/or SENSITIVITY settings.

For 7M5/7M7 (twin rod/cable):

1. Nozzle should be DN80 (3") diameter or larger.
2. For nozzles < DN80 (3") diameter, the bottom of the inactive section of the probe should be flush with the bottom of the nozzle or extend into the vessel.

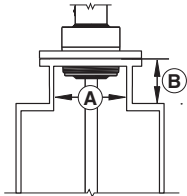

Correct installation

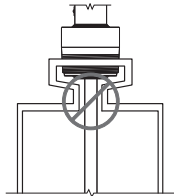

Pipe reducers should not be used

High level shutdown / Overfill protection

Special consideration is necessary in any high level shutdown / overfill protection application where guided wave radar is to be used for. To ensure proper measurement, the guided wave radar probe should be installed so the maximum overfill level is at a minimum of 120 mm (4.8") up to 910 mm (36") – blocking distance depending application below the process connection. Consult factory for further information.

3. Metallic (conductive) obstructions in tank.

Distance to probe	Acceptable objects
< 150 mm (6")	Continuous, smooth, parallel, conductive surface (e.g. metal tank wall); probe should not touch tank wall
> 150 mm (6")	< 1"/DN25 diameter pipe and beams, ladder rungs
> 300 mm (12")	< 3"/DN80 diameter pipe and beams, concrete walls
> 450 mm (18")	All remaining objects

4. Non-metallic vessels

For 7MF/7M1/7M2/7MJ (single rod/cable)

1. Flange (metal) mounting is recommended for optimum performance.
2. Mount probe more than 450 mm (18") from vessel wall.

5. Metallic obstructions

For 7MF/7M1/7M2 (single rod/cable)

A metal stillwell/cage of max. 6"/DN size or a metal tank wall within 150 mm of the probe mounting will allow the unit operate accurately in media with dielectrics down to ϵ_r 1.9.

Objects in the proximity can cause erroneous readings

For 7M5/7M7 (twin rod/cable)

Mount the probe more than 25 mm (1") from any metallic object/vesselwall.

2. Order code for ECLIPSE 705 - sanitary CIP/SIP GWR probe (finished to 0,5 µm - RA 20) for liquids (for in-tank mounting only)

BASIC MODEL NUMBER

7	M	F	-	E	sanitary CIP/SIP GWR probe in 316/316L (1.4401/1.4404) stainless steel (dielectric range: ≥ 1.9/10)	
---	---	---	---	---	---	--

PROCESS CONNECTION - SIZE/TYPE

4	P	2" - 3A Tri-clover compatible 16 AMP fitting
5	P	3" - 3A Tri-clover compatible 16 AMP fitting
6	P	4" - 3A Tri-clover compatible 16 AMP fitting

INSERTION LENGTH – Specify insertion length per cm (0.39") increments

0	6	0	minimum 60 cm (24") insertion length
6	1	0	maximum 610 cm (240") insertion length

7	M	F	-	E	P	N		
---	---	---	---	---	---	---	--	--

complete order code for ECLIPSE sanitary CIP/SIP - GWR probe

DIMENSIONS in mm (inches)

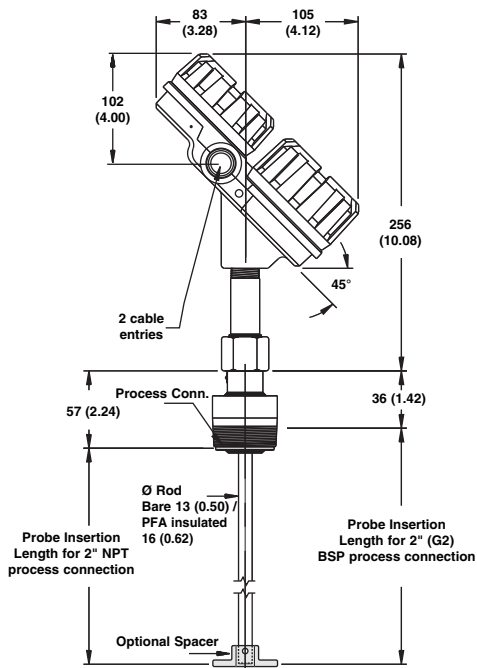

**7MF/7MJ
with threaded connection
max. 6 m (240")**

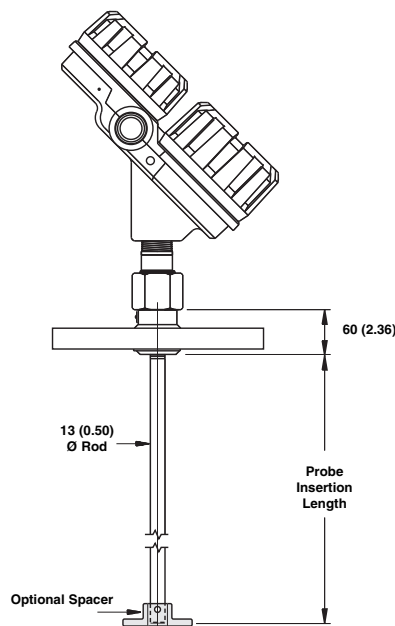

**7MF/7MJ
with flanged connection
max. 6 m (240")**

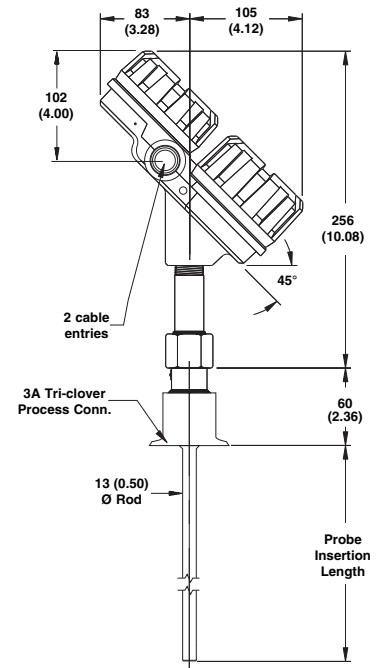

**7MF-E
with sanitary
Tri-clover connection
max. 6 m (240")**

MOUNTING

Consult mounting considerations on page 15

2. Order code for ECLIPSE 705 GWR probe for liquids (for in-tank mounting only)

- 316/316L (1.4401/1.4404) material for standard applications
- Hastelloy C (2.4819) or Monel (2.4360) for extreme aggressive media
- PFA insulated for applications with excessive coating / build up.

BASIC MODEL NUMBER

7 M F	Standard single rod GWR probe	(dielectric range: ≥ 1,9/10)
7 M J	High temperature / high pressure single rod GWR probe	(dielectric range: ≥ 1,9/10)

MATERIAL OF CONSTRUCTION

A	316/316L (1.4401/1.4404) stainless steel	for 7MF/7MJ
B	Hastelloy C (2.4819)	for 7MF/7MJ
C	Monel (2.4360)	for 7MF/7MJ
4	PFA insulated 316/316L (1.4401/1.4404) SST	for 7MF

PROCESS CONNECTION - SIZE/TYPE

Threaded

4 1	2" NPT thread
4 2	2" BSP (G2) thread

ANSI flanged ①

4 3	2" 150 lbs. ANSI RF
4 4	2" 300 lbs. ANSI RF
4 5	2" 600 lbs. ANSI RF
4 K	2" 600 lbs. ANSI RJ
4 M	2" 900/1500 lbs. ANSI RJ
5 3	3" 150 lbs. ANSI RF flange
5 4	3" 300 lbs. ANSI RF flange
5 5	3" 600 lbs. ANSI RF flange
5 K	3" 600 lbs. ANSI RJ flange
5 L	3" 900 lbs. ANSI RJ flange
5 M	3" 1500 lbs. ANSI RJ flange
6 3	4" 150 lbs. ANSI RF flange
6 4	4" 300 lbs. ANSI RF flange
6 5	4" 600 lbs. ANSI RF flange
6 K	4" 600 lbs. ANSI RJ flange
6 L	4" 900 lbs. ANSI RJ flange
6 M	4" 1500 lbs. ANSI RJ flange

EN/DIN flanged ①

D A	DN 50, PN 16	EN 1092-1 Type A
D B	DN 50, PN 25/40	EN 1092-1 Type A
D D	DN 50, PN 63	EN 1092-1 Type B2
D E	DN 50, PN 100	EN 1092-1 Type B2
D F	DN 50, PN 160	DIN 2527 form E
D G	DN 50, PN 250	DIN 2527 form E
E A	DN 80, PN 16	EN 1092-1 Type A
E B	DN 80, PN 25/40	EN 1092-1 Type A
E D	DN 80, PN 63	EN 1092-1 Type B2
E E	DN 80, PN 100	EN 1092-1 Type B2
E F	DN 80, PN 160	DIN 2527 Form E
E G	DN 80, PN 250	DIN 2527 Form E
F A	DN 100, PN 16	EN 1092-1 Type A
F B	DN 100, PN 25/40	EN 1092-1 Type A
F D	DN 100, PN 63	EN 1092-1 Type B2
F E	DN 100, PN 100	EN 1092-1 Type B2
F F	DN 100, PN 160	DIN 2527 Form E
F G	DN 100, PN 250	DIN 2527 Form E

① 7MF up to 600 lbs ANSI RF / PN 100 flanges

PROCESS SEAL - MATERIAL

0	Viton® GFLT seal - for universal use / steam applications	-40 °C (-40 °F) / +200 °C (+400 °F) – 7MF
1	EPDM (Ethylene Propylene) - for e.g. caustic soda applications	-50 °C (-60 °F) / +125 °C (+250 °F) – 7MF
2	Kalrez 4079 seal - for aggressive media	-40 °C (-40 °F) / +200 °C (+400 °F) – 7MF
8	PEEK seal - for high temperature / high pressure	-15 °C (0 °F) / +315 °C (+600 °F) – 7MJ

Consult factory for alternative seal materials. For Ammonia/Chlorine applications, use the 7MD GWR probe. Viton® is a registered trademark of DuPont Performance Elastomers.

INSERTION LENGTH – Specify insertion length per cm (0.39") increments

0 6 0	minimum 60 cm (24") insertion length
6 1 0	maximum 610 cm (240") insertion length

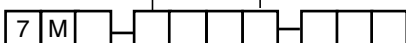

complete order code for ECLIPSE 705 - bare or PFA insulated GWR probe

DIMENSIONS in mm (inches)

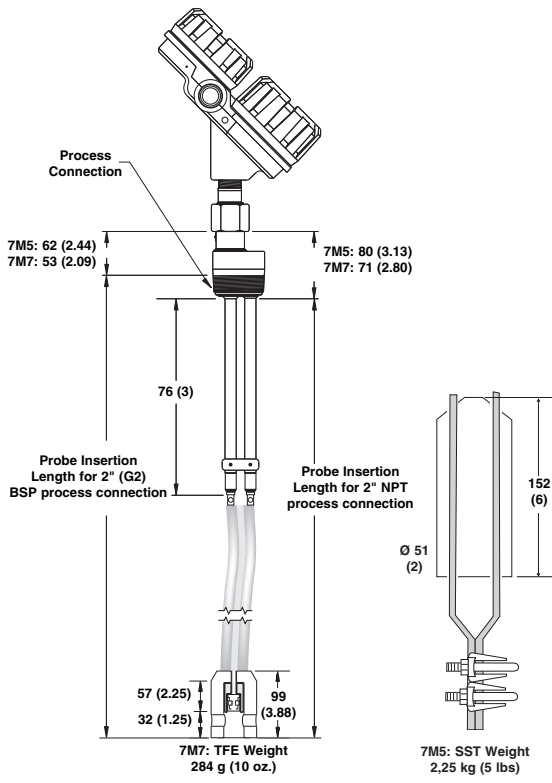

7M5/7M7
with threaded connection
max. 22 m (75')

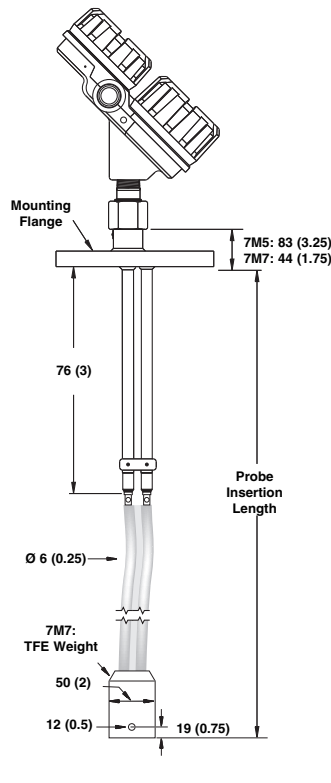

7M5/7M7
with flanged connection
max. 22 m (75')

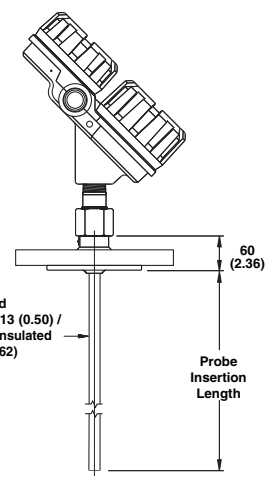

7MF-F
with faced-flanged
connection
max. 6 m (240")

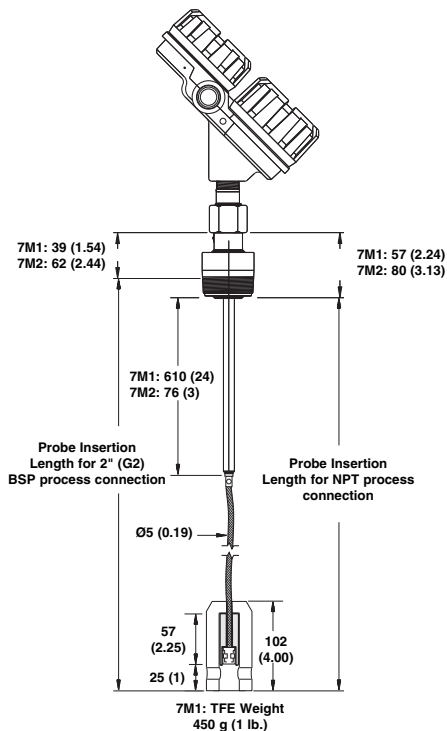

7M1/7M2 with threaded connection
max. 22 m (75')

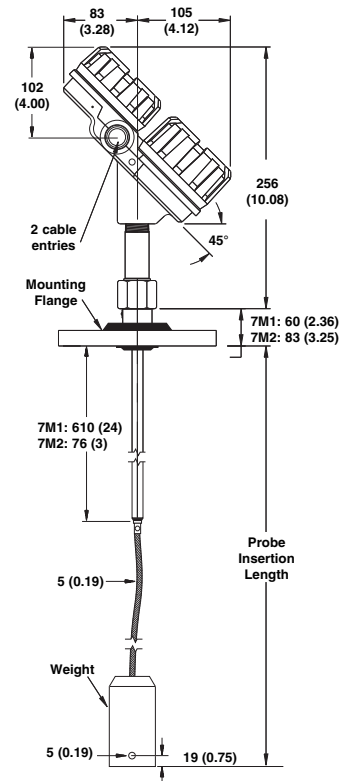

7M1/7M2 with flanged connection
max. 22 m (75')

MOUNTING

Consult mounting considerations on page 15

2. Order code for ECLIPSE 705 - PFA insulated / faced flange GWR probe - for aggressive liquids (for in-tank mounting only)

BASIC MODEL NUMBER

7	M	F	-	F	Single rod PFA insulated 316/316L (1.4401/1.4404) GWR probe	(dielectric range: $\geq 1,9/10$)
---	---	---	---	---	---	------------------------------------

PROCESS CONNECTION - SIZE/TYPE
ANSI flanged

4	3	2"	150 lbs.	ANSI RF flange
4	4	2"	300 lbs.	ANSI RF flange
4	5	2"	600 lbs.	ANSI RF flange
5	3	3"	150 lbs.	ANSI RF flange
5	4	3"	300 lbs.	ANSI RF flange
5	5	3"	600 lbs.	ANSI RF flange
6	3	4"	150 lbs.	ANSI RF flange
6	4	4"	300 lbs.	ANSI RF flange
6	5	4"	600 lbs.	ANSI RF flange

EN/DIN flanged

D	A	DN 50, PN 16	EN 1092-1 Type A
D	B	DN 50, PN 25/40	EN 1092-1 Type A
D	D	DN 50, PN 63	EN 1092-1 Type B2
D	E	DN 50, PN 100	EN 1092-1 Type B2
E	A	DN 80, PN 16	EN 1092-1 Type A
E	B	DN 80, PN 25/40	EN 1092-1 Type A
E	D	DN 80, PN 63	EN 1092-1 Type B2
E	E	DN 80, PN 100	EN 1092-1 Type B2
F	A	DN 100, PN 16	EN 1092-1 Type A
F	B	DN 100, PN 25/40	EN 1092-1 Type A
F	D	DN 100, PN 63	EN 1092-1 Type B2
F	E	DN 100, PN 100	EN 1092-1 Type B2

INSERTION LENGTH – Specify insertion length per cm (0.39") increments

0	6	0	minimum 60 cm (24") insertion length
6	1	0	maximum 610 cm (240") insertion length

7	M	F	-	F		N			
---	---	---	---	---	--	---	--	--	--

complete order code for ECLIPSE 705 - PFA insulated / faced flange GWR probe

2. Order code for ECLIPSE 705 - flexible cable GWR probe for liquids or solids (for in-tank mounting only)

BASIC MODEL NUMBER

7	M	1	-	A	Single cable GWR probe in 316 stainless steel (1.4401)	(dielectric range: $\geq 1,9/10$)	liquids
7	M	7	-	A	Twin cable GWR probe in FEP coated 316 SST (1.4401)	(dielectric range: $\geq 1,9$)	liquids
7	M	2	-	A	Single cable GWR probe in 316 stainless steel (1.4401)	(dielectric range: $\geq 4,0$)	solids
7	M	5	-	A	Twin cable GWR probe in TFE coated 316 SST (1.4401)	(dielectric range: $\geq 1,9$)	solids

PROCESS CONNECTION - SIZE/TYPE
Threaded

4	1	2" NPT thread
4	2	2" BSP (G2) thread

ANSI flanged

4	3	2"	150 lbs.	ANSI RF flange
4	4	2"	300 lbs.	ANSI RF flange
4	5	2"	600 lbs.	ANSI RF flange
5	3	3"	150 lbs.	ANSI RF flange
5	4	3"	300 lbs.	ANSI RF flange
5	5	3"	600 lbs.	ANSI RF flange
6	3	4"	150 lbs.	ANSI RF flange
6	4	4"	300 lbs.	ANSI RF flange
6	5	4"	600 lbs.	ANSI RF flange

EN/DIN flanged

D	A	DN 50, PN 16	EN 1092-1 Type A
D	B	DN 50, PN 25/40	EN 1092-1 Type A
D	D	DN 50, PN 63	EN 1092-1 Type B2
D	E	DN 50, PN 100	EN 1092-1 Type B2
E	A	DN 80, PN 16	EN 1092-1 Type A
E	B	DN 80, PN 25/40	EN 1092-1 Type A
E	D	DN 80, PN 63	EN 1092-1 Type B2
E	E	DN 80, PN 100	EN 1092-1 Type B2
F	A	DN 100, PN 16	EN 1092-1 Type A
F	B	DN 100, PN 25/40	EN 1092-1 Type A
F	D	DN 100, PN 63	EN 1092-1 Type B2
F	E	DN 100, PN 100	EN 1092-1 Type B2

PROCESS SEAL - MATERIAL

0	Viton® GFLT seal - for universal use / steam applications	-40 °C (-40 °F) / +200 °C (+400 °F)
1	EPDM (Ethylene Propylene) - for e.g. caustic soda applications	-50 °C (-60 °F) / +125 °C (+250 °F)
2	Kalrez 4079 seal - for aggressive media	-40 °C (-40 °F) / +200 °C (+400 °F)

Consult factory for alternative seal materials. For ammonia/chloride applications, use the 7MD GWR probe. Viton® is a registered trademark of DuPont Performance Elastomers.

INSERTION LENGTH: – Specify insertion length per 1 m (3,28') increments
Probes can be cut to exact length in the field

0	0	1	minimum 1 m (3,28') insertion length - 7M1
0	0	2	minimum 2 m (6,56') insertion length - 7M2/7M7/7M5
0	2	2	maximum 22 m (75') insertion length

7	M			A					
---	---	--	--	---	--	--	--	--	--

complete order code for ECLIPSE 705 - flexible cable GWR probe

TRANSMITTER SPECIFICATIONS

FUNCTIONAL/PHYSICAL

Description		Specification
Power (at terminals)		General Purpose / ATEX Intrinsically Safe: 11 to 28,6 V DC ATEX Explosion Proof (with Intrinsically Safe probe) 11 to 36 V DC Foundation Fieldbus (FISCO ATEX Exi): 9 to 17,5 V DC Foundation Fieldbus (FNICO & Exd): 9 to 32 V DC
Signal Output		4-20 mA with HART®, 3,8 mA to 20,5 mA useable (meets NAMUR NE 43) or Foundation Fieldbus H1 (ITK Ver. 4)
Span	Rigid probes	150 to 6100 mm (6 to 240") except 7MS: max 4500 mm (177")
	Flexible probes	15 cm to 2285 cm (6 to 75')
Resolution		Analog: 0,01 mA Display: 0,1 cm (inch)
Loop Resistance (see tables at page 12)		630 Ω @ 20,5 mA - 24 V DC
Damping		Adjustable 0-10 s
Diagnostic Alarm		Adjustable 3,6 mA, 22 mA, HOLD
User Interface		HART® communicator, AMS® or PACTware®, Foundation Fieldbus and/or 3-button keypad
Display		2-line x 8-character LCD
Menu Language		English/Spanish/French/German (Foundation Fieldbus: English)
Housing Material		IP 66/Aluminium A356T6 (< 0.20 % copper) or stainless steel
Approvals		ATEX II 3 (1) G EEx nA II T6, non sparking (probe can be used in flammable liquids) ATEX II 3 (1) G EEx nA [ia] IIC T6, FNICO – FF non incendive (probe can be used in flammable liquids) ATEX II 1 G EEx ia IIC T4, intrinsically safe ATEX II 1 G EEx ia IIC T4, FISCO – FF intrinsically safe ATEX II 1 / 2 G D EEx d[ia] IIC T6, explosion proof ^① FM and CSA, Non incendive, intrinsically safe (FISCO) and explosion proof STOOMWEZEN – Secondary level safety device for steamdrums TÜV – WHG § 19, VLAREM II 5.17-7 LRS – Lloyds Register of Shipping (marine applications) GOST-K/GGTN-K – RosTECH/FSTS – Russian Authorisation Standards
SIL ^② (Safety Integrity Level)	Standard electronics	Functional safety to SIL 1 / SIL 2 in accordance to 61508 – SFF of 85,4 % – full FMEDA reports and declaration sheets available at request
	Enhanced electronics	Functional safety to SIL 2 / SIL 3 in accordance to 61508 – SFF of 91 % – full FMEDA reports and declaration sheets available at request
Electrical Data		U _i = 28,4 V, I _i = 94 mA, P _i = 0,67 W U _i = 0,56 V, I _i = 380 mA, P _i = 5,32 W (Foundation Fieldbus)
Equivalent Data		C _i = 2,2 nF, L _i = 3 μH C _i = 0,24 nF, L _i = 3 μH (Foundation Fieldbus)
Shock/Vibration Class		ANSI/ISA-571.03 SA1 (Shock), ANSI/ISA-571.03 VC2 (Vibration)
Net and Gross Weight	Cast aluminium	2,70 kg net; 3,20 kg gross – amplifier only
	Stainless steel	5,70 kg net; 6,20 kg gross – amplifier only
Overall Dimensions		H 214 mm (8.43") x W 111 mm (4.38") x D 188 mm
Foundation Fieldbus specifications	ITK Version	4.61
	H1 Device Class	Link Master (LAS) – selectable ON/OFF
	H1 Profile Class	31PS, 32L
	Function Blocks	1 x RB(s), 4 x AI (s) and 1 x TB (c)
	Quiescent current draw	15 mA
	Execution time	15 ms
	CFF files	Downloads available from Host system supplier or www.fieldbus.org

① ATEX, explosion proof units use EEx d bushing material STYCAST 2057 FR.

② Not applicable for Foundation Fieldbus units.

PERFORMANCE

Description		Specification
Reference Conditions with a 1,8 m (72") coaxial type GWR probe		Reflection from liquid, with dielectric in center of selected range, at +20 °C (70 °F) with CFD threshold ^①
Linearity ^②	Coaxial/twin lead probes	< 0,1 % of probe length or 2,5 mm (0.1"), whichever is greater
	Single lead probes	< 0,3 % of probe length or 8 mm (0.3"), whichever is greater
Accuracy ^②	Coaxial/twin lead probes	< 0,1 % of probe length or 2,5 mm (0.1"), whichever is greater
	Single lead probes	± 0,5 % of probe length or 13 mm (0.5"), whichever is greater
	7MT interface	± 25 mm (1")
Resolution		± 2,5 mm (0.1")
Repeatability		< 2,5 mm (0.1")
Hysteresis		< 2,5 mm (0.1")
Response Time		< 1 second
Warm-up Time		< 5 seconds
Ambient Temp.		-40 °C to +80 °C (-40 °F to +175 °F) – blind transmitter -20 °C to +70 °C (-5 °F to +160 °F) – with digital display -40 °C to +70 °C (-40 °F to +160 °F) – for EEx ia and EEx d[ia] with blind transmitter -20 °C to +70 °C (-5 °F to +160 °F) – for EEx ia and EEx d[ia] with digital display
Process Dielectric Effect		< 7,5 mm (0.3") within selected range
Operating Temp. Effect		Approx. +0,02 % of probe length/°C for probes ≥ 2,5 m (8") ^③
Humidity		0-99 %, non-condensing
Electromagnetic Compatibility		Meets CE requirements (EN-61000-6-4, EN 61000-6-2) and NAMUR NE 21 (Single and Twin-Rod probe must be used in metallic vessel or stillwell)

PROBE SPECIFICATIONS

Description		7MR: overfill protection coaxial probe ^④	7MA: coaxial GWR probe
Materials	Probe	316/316L (1.4401/1.4404) with TFE spacers Hastelloy C [®] (2.4819) or Monel [®] (2.4360) with TFE spacers	
	Process seal	TFE with Viton [®] GFLT, EPDM, Aegis [®] PF 128 or Kalrez 4079 (Consult factory for alternatives)	
Probe diameter		Standard: inside rod 8 mm (0.31") – outer tube 22 mm (0.87") Enlarged: inside tube 16 mm (0.63) – outer tube 45 mm (1.75")	
Mounting		In-tank mounting / external cage mounting (WHG approved)	In-tank mounting only
Process Connection		Threaded: 3/4" NPT or 1" BSP (G1) – except for larger Ø probe Flanged: Various ANSI, DIN or torque tube mating flanges	
Probe length (selectable per 1 cm)		From 60 cm to 610 cm (24 to 240"), selectable per 10 mm	
Transition Zone ^①	Top	0 mm (0")	Er: 1,4 = 25 mm (1")/Er: 80 = 150 mm (6")
	Bottom	Er: 1,4 = 150 mm (6")/Er: 80 = 25 mm (1")	Er: 1,4 = 150 mm (6")/Er: 80 = 25 mm (1")
Max. Process Temp. ^③	Max	+200 °C @ 18 bar (+400 °F @ 270 psi)	+150 °C @ 27 bar (+300 °F @ 400 psi)
	Min	-40 °C @ 50 bar (-40 °F @ 750 psi)	
Max. Process Pressure ^③		70 bar @ +20 °C (1000 psi @ +70 °F)	
Dielectric Range – Max. Viscosity		1,4 to 100 – 500 cP	

Description		7MD: high pressure/high temperature GWR probe ^③	7MS: saturated steam GWR probe
Materials	Probe	316/316L (1.4401/1.4404), Hastelloy C [®] (2.4819) or Monel [®] (2.4360)	
	Process seal	Borosilicate/inconel X750	High Temp PEEK with Aegis PF 128
	Spacers	Alumina (7MD-A, B and C) – TFE (7MD-W) – High Temp PEEK (7MD-V, N, P and R)	High Temp PEEK
Probe diameter		Standard: inside rod 8 mm (0.31") – outer tube 22 mm (0.87") Enlarged: inside tube 16 mm (0.63) – outer tube 45 mm (1.75")	
Mounting		In-tank mounting / external cage mounting (7MD: WHG / 7MS: EN 12952-11 (water tube boilers) and EN 12953-9 (Shell boilers) approved)	
Process Connection		Threaded: 3/4" NPT or 1" BSP (G1) – except for larger Ø probe Flanged: Various ANSI, DIN or "proprietary" mating flanges	
Probe length (selectable per 1 cm)		From 60 cm to 610 cm (24 to 240")	From 60 cm to 450 cm (24 to 177")
Transition Zone ^①	Top	0 mm (0")	
	Bottom	Er: 1,4 = 150 mm (6") / Er: 80 = 25 mm (1")	Er ≥ 10 = 25 mm (1")
MaxProcess Temp. ^③	Max	+430 °C @ 135 bar (+800 °F @ 2000 psi) +345 °C (+650 °F) for 7MD-V, N, P and R +200 °C (+400 °F) for 7MD-W	+345 °C @ 155 bar (+650 °F @ 2250 psi)
	Min	-196 °C @ 135 bar (-320 °F @ 2000 psi)	-15 °C @ 205 bar (0 °F @ 3000 psi)
Max. Process Pressure ^③		430 bar @ +20 °C (6250 psi @ +70 °F)	155 bar @ +345 °C (2250 psi @ +650 °F)
Max. Viscosity		500 cP (standard) / 1500 cP (enlarged)	
Dielectric Range		Er ≥ 1,4-100: 7MD-W Er ≥ 1,7-100: 7MD-V, N, P and R Er ≥ 2,0-100: 7MD-A, B and C	10 to 100
Vacuum service		Full vacuum (Helium leak < 10 ⁸ cc/s @ 1 atmosphere vacuum)	Negative pressure but not up to full vacuum

^① May degrade for 7MD probe or with fixed threshold.

^② Top 600 mm (24") of twin rod probe: 30 mm (1.18").
Top 1220 mm (48") of single rod: application dependant.

^③ Accuracy may degrade slightly < 2,5 m (8')

^④ For 7MR/7MT and 7MD: Consult factory for insertion length < 60 cm (24")

Description		7MT: interface GWR probe^④	7MB: standard twin rod GWR probe
Materials	Probe	316/316L (1.4401/1.4404) Hastelloy C [®] (2.4819) or Monel [®] (2.4360)	
	Process seal	TFE with Viton [®] GFLT, EPDM or Kalrez 4079 (Consult factory for alternatives)	
	Spacers	Teflon	
Probe diameter		Standard: inside rod 8 mm (0.31") – outer tube 22 mm (0.87") Optional: inside tube 16 mm (0.63) – outer tube 45 mm (1.75")	Two 13 mm (0.5") Ø rods – 22 mm (0.875") \varnothing to \varnothing
Mounting		In-tank mounting / external cage mounting – overflow safe	In-tank mounting only. Twin rod probe must be used in metallic vessel or stillwell > 25 mm (1") from any surface or obstruction
Process Connection		Threaded: 3/4" NPT or 1" BSP (G1) – except for larger Ø probe Flanged: Various ANSI, DIN or "proprietary" mating flanges	Threaded: 2" NPT or 2" BSP (G2) Flanged: Various ANSI, DIN or "proprietary" mating flanges
Probe length (selectable per 1 cm)		From 60 cm to 610 cm (24 to 240"), selectable per 10 mm	
Transition Zone ^①	Top	0 mm (0")	$\epsilon_r \geq 1,9 = 150 \text{ mm (6")}$
	Bottom	$\epsilon_r: 1,4 = 150 \text{ mm (6")}/\epsilon_r: 80 = 50 \text{ mm (2")}$	$\epsilon_r: 1,9 = 150 \text{ mm (6")}/\epsilon_r: 80 = 25 \text{ mm (1")}$
Process Temp. ^③	Max	+200 °C @ 18 bar (+400 °F @ 270 psi)	+150 °C @ 20 bar (+300 °F @ 300 psi) / +200 °C (+400 °F) with max ambient temp. of +30 °C (+86 °F)
	Min	-40 °C @ 50 bar (-40 °F @ 750 psi)	
Max. Process Pressure ^③		70 bar @ +20 °C (1000 psi @ +70 °F)	50 bar @ +20 °C (750 psi @ +70 °F)
Dielectric Range – Max. Viscosity		Upper liquid: $\geq 1,4$ and ≤ 5 Lower liquid: ≥ 15	1,9 to 100 – 1500 cP
Vacuum service		Negative pressure but not up to full vacuum	
Media coating		In case of media coating, select larger Ø probe.	Film: 3% error of coated length, bridging not recommended ^②

Description		7MF: standard single rod	7MJ: HTHP single rod
Materials	Probe	316/316L (1.4401/1.4404), Monel [®] (2.4360), Hastelloy C [®] (2.4819) or PFA insulated 316/316L (1.4401/1.4404)	
	Process seal	TFE with Viton [®] GFLT, EPDM or Kalrez 4079 (Consult factory for alternatives)	PEEK with Aegis PF 128
Probe diameter		Bare: 13 mm (0.50") - PFA coated: 16 mm (0.625")	Bare: 13 mm (0.50")
Mounting		See mounting considerations on page 15	
Process Connection		Threaded: 2" NPT or 2" BSP (G2) – Flanged: Various ANSI, EN/DIN or sanitary	
Probe length		From 600 mm to 6100 mm (24" to 240") (selectable per 1 cm)	
Blocking distance (top)		120 mm up to 910 mm (4.8" up to 36") - depending probe length (adjustable)	
Transition Zone ^① (bottom)		$\epsilon_r \geq 10: 25 \text{ mm (1")}$	305 mm (12")
Process Temp.	Max	+150 °C @ 27 bar (+300 °F @ 400 psi) ambient	+315 °C @ 110 bar (+600 °F @ 1600 psi)
	Min	-40 °C @ 50 bar (-40 °F @ 750 psi) – 13,7 bar (200 psi) for 7MF-F	
Max Process Pressure		70 bar @ +20 °C (1000 psi @ +70 °F) – All except 7MF-E 5 bar @ +150 °C (73 psi @ +300 °F) – 7MF-E 13,7 bar @ -40 °C (200 psi @ -40 °F) – 7MF-F	207 bar @ +20 °C (3000 psi @ +70 °C)
Max Viscosity		10.000 cP – consult factory in case of agitation/turbulence	
Dielectric Range		ϵ_r 10-100 (depending installation conditions, down to $\epsilon_r \geq 1,9$) – liquids	
Mechanical load		Not applicable	
Pull-down force		Not applicable	
Media coating		Max error of 10 % of coated length. % Error is related to dielectric of medium, thickness of coating and coated probe length above level.	

① Transition Zone (zone with reduced accuracy) is dielectric dependent; ϵ_r = dielectric permittivity. It is recommended to set 4-20 mA signal outside transition zones.

② Bridging is defined as continuous accumulation of material between the probe elements.

③ See tables at page 23.

④ For 7MR/7MT and 7MD: Consult factory for insertion length < 60 cm (24")

Description		7M1 (liquids) / 7M2 (solids): single flexible	7M5 (solids) / 7M7 (liquids): twin flexible
Materials	Probe	316 SST (1.4401)	7M7: FEP coated 316 SST (1.4401) 7M5: TFE coated 316 SST (1.4401)
	Process seal	TFE with Viton® GFLT, EPDM or Kalrez 4079 (Consult factory for alternatives)	
Probe diameter		7M1: 5 mm (0.19") 7M2: 6 mm (0.25")	6 mm (0.25")
Mounting		See mounting considerations on page 15	< 25 mm (1") from any surface or construction
Process Connection		Threaded: 2" NPT or 2" BSP (G2) – Flanged: Various ANSI, EN/DIN or sanitary	
Probe length		From 1 m (3') (7M1) - 2 m (6') (7M2, 7M5, 7M7) to max 22 m (75') (selectable per 1 cm)	
Blocking distance (top)		120 mm up to 910 mm (4.8" up to 36") - depending probe length (adjustable)	300 mm to 500 mm (12" to 20")
Transition Zone ^① (bottom)		305 mm (12")	
Max Process Temp.		+150 °C @ 27 bar (300 °F @ 400 psi) – 7M2/7M5: Ambient	
Max Process Pressure		7M1/7M7: 70 bar @ +20 °C (1000 psi @ +70 °F) 7M2/7M5: 3.4 bar (50 psi)	
Max Viscosity		10.000 cP – consult factory in case of agitation/turbulence	1500 cP
Dielectric Range		ε _r 10-100 (depending installation conditions down to ε _r ≥ 1,9) – liquids ε _r 4-100 – solids	ε _r 1,9-100
Mechanical load		89 N (20 lbs) – 7M1	
Pulldown force		1360 kg (3000 lbs) – 7M2	1360 kg (3000 lbs) – 7M5
Media coating		Max error of 10 % of coated length. % Error is related to dielectric of medium, thickness of coating and coated probe length above level.	Film: 3 % max error of coated length with conductive media – Bridging not recommended

① Transition Zone (zone with reduced accuracy) is dielectric dependent; ε_r = dielectric permittivity. It is recommended to set 4-20 mA signal outside the transition zone / blocking distance.

Viton® is a registered trademark of DuPont Performance Elastomers.

Description		7EK: Top/Bottom GWR probe min ε_r 1,4 - max +260 °C	7EK: Top/Bottom GWR probe min ε_r 10 - max +320 °C
Materials	Probe	316/316L (1.4401/1.4404)	
	Process seal	PEEK and TFE with Aegis PF 128	PEEK and Alumina with Aegis PF 128
	Bottom spacer	TFE	PEEK
Probe diameter		Inside tube: max 22 mm (0.875")	
Cage		2" - Sch 80 Top/Bottom cage	
Process Connection		Threaded: 1 1/2" NPT or 2" NPT Welded: 2" socket weld Flanged: Various ANSI, DIN or "proprietary" mating flanges	
Measuring range		min 356 mm (14") Std. – max 6,1 m (240")	
Process Temp.	Max	+260 °C @ 120 bar (+500 °F @ 1700 psi)	+320 °C @ 110 bar (+605 °F @ 1585 psi)
	Min	-15 °C @ 205 bar (0 °F @ 3000 psi)	
Max. Process Pressure		205 bar @ -15 °C (3000 psi @ +0 °F)	
Max. Viscosity		10.000 cP	
Dielectric Range		1,4 to 100 - Non conductive and conductive media	10 to 100 - Conductive media
Vacuum service		Negative pressure but not up to full vacuum	

TEMPERATURE-PRESSURE RATING FOR ECLIPSE PROBE SEALS

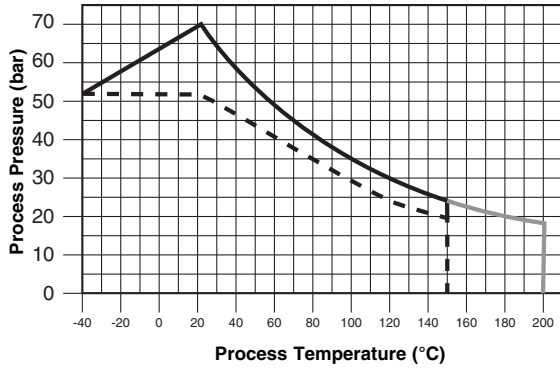

- 7MA/7M1/7M7/7MF GWR probes
- - - - 7MB GWR probes
- 7MR/7MT GWR probes

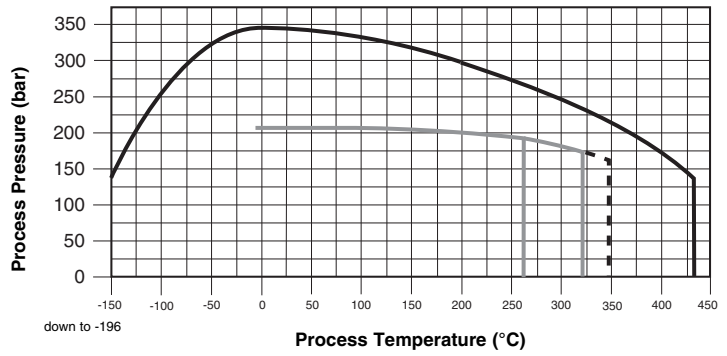

- 7MD GWR probe
- - - - 7MS/7MJ GWR probes (7MJ max +315 °C)
- 7EK: top/bottom GWR probe:
 - max +260 °C for conductive and non conductive liquids
 - max +320 °C for conductive liquids only

PROBE CONNECTION STYLES

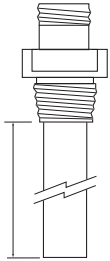

Insertion Length
NPT Process Connection

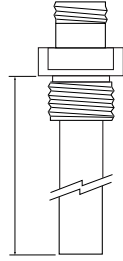

Insertion Length
BSP Process Connection

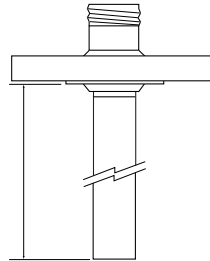

Insertion Length
ANSI or DIN Welded Flange

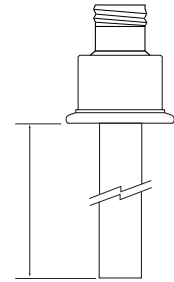

Insertion Length
Sanitary Flange



QUALITY ASSURANCE - ISO 9001:2000

THE QUALITY ASSURANCE SYSTEM IN PLACE AT MAGNETROL GUARANTEES THE HIGHEST LEVEL OF QUALITY DURING THE DESIGN, THE CONSTRUCTION AND THE SERVICE OF CONTROLS. OUR QUALITY ASSURANCE SYSTEM IS APPROVED AND CERTIFIED TO ISO 9001:2000 AND OUR TOTAL COMPANY IS COMMITTED TO PROVIDING FULL CUSTOMER SATISFACTION BOTH IN QUALITY PRODUCTS AND QUALITY SERVICE.

PRODUCT WARRANTY

ALL MAGNETROL ELECTRONIC AND ULTRASONIC LEVEL CONTROLS ARE WARRANTED FREE OF DEFECTS IN MATERIALS AND WORKMANSHIP FOR ONE FULL YEAR FROM THE DATE OF ORIGINAL FACTORY SHIPMENT. IF RETURNED WITHIN THE WARRANTY PERIOD; AND, UPON FACTORY INSPECTION OF THE CONTROL, THE CAUSE OF THE CLAIM IS DETERMINED TO BE COVERED UNDER THE WARRANTY; THEN, MAGNETROL INTERNATIONAL WILL REPAIR OR REPLACE THE CONTROL AT NO COST TO THE PURCHASER (OR OWNER) OTHER THAN TRANSPORTATION.

MAGNETROL SHALL NOT BE LIABLE FOR MISAPPLICATION, LABOR CLAIMS, DIRECT OR CONSEQUENTIAL DAMAGE OR EXPENSE ARISING FROM THE INSTALLATION OR USE OF THE EQUIPMENT. THERE ARE NO OTHER WARRANTIES EXPRESSED OR IMPLIED, EXCEPT, SPECIAL WRITTEN WARRANTIES COVERING SOME MAGNETROL PRODUCTS.



BULLETIN N°:
EFFECTIVE:
SUPERSEDES:

BE 57-101.15
NOVEMBER 2006
October 2005

UNDER RESERVE OF MODIFICATIONS

BENELUX	Heikensstraat 6, 9240 Zele, België Tel. +32 (0)52.45.11.11 • Fax. +32 (0)52.45.09.93 • E-Mail: info@magnetrol.be
DEUTSCHLAND	Alte Ziegelei 2-4, D-51491 Overath Tel. 02204 / 9536-0 • Fax. 02204 / 9536-53 • E-Mail: vertrieb@magnetrol.de
FRANCE	40 - 42, rue Gabriel Péri, 95130 Le Plessis Bouchard Tél. 01.34.44.26.10 • Fax. 01.34.44.26.06 • E-Mail: magnetrolfrance@magnetrol.fr
ITALIA	Via Aresè 12, I-20159 Milano Tel. (02) 607.22.98 (R.A.) • Fax. (02) 668.66.52 • E-Mail: mit.gen@magnetrol.it
UNITED KINGDOM	Unit 1 Regent Business Centre, Jubilee Road Burgess Hill West Sussex RH 15 9TL Tel. (01444) 871313 • Fax (01444) 871317 • E-Mail: sales@magnetrol.co.uk
INDIA	E-22, Anand Niketan, New Delhi - 110 021 Tel. 91 (11) 41661840 • Fax 91 (11) 41661843 • E-Mail: info@magnetrolindia.com

www.magnetrol.com

OUR NEAREST REPRESENTATIVE