

DESCRIPTION

The Echotel 961/962 series utilizes pulse signal technology to detect high or low level alarm(s) in a broad range of viscous to light liquids. Pulsed signal technology provides superior performance in applications suffering from foam, aeration, heavy turbulence and suspended solids.

The Echotel **961** has a tip sensitive setpoint and is ideally used as high or low level alarm.

The Echotel **962** offers 2 setpoints on the same transducer, a tip sensitive setpoint and a second setpoint via a flow-through upper gap. The unit is used for level alarm or to control a pump in an auto fill/empty mode.

The Echotel 961/962 is equipped with advanced diagnostics that continuously check the transducer and electronics. The diagnostics also alarm for electrical noise interference from external sources.

FEATURES

- No calibration
- 2 wire loop powered with mA output or AC/DC line powered with integrated relay(s)
- Continuous selftest with selectable error output
- LED identification for:
 - process alarm
 - error of transducer, electronics or electrical noise interference
 - wet/dry status of transducer
- Push buttons for manual testing of alarm and error signals
- Adjustable time delay up to 45 s
- Metal and plastic transducers
- High pressure/ temperature ratings
 - Metal transducers: max 135 bar @ max +165 °C / (min -80 °C)
 - Plastic transducers: max 19 bar / max +120 °C
- Suited for SIL 1, 2 and SIL 3 loops (full FMEDA report available)



APPLICATIONS

- LIQUIDS: Any liquids with a viscosity < 10.000 cP.
- VESSELS: Any mounting position.
- PROCESS CONDITIONS: Unaffected by
 - shifting dielectric, density, or PH
 - presence of foam, turbulence, visible vapors
 - fast drain/fill rates
 - transducer coating and air bubbles
 - vacuum conditions.

Loop or line powered

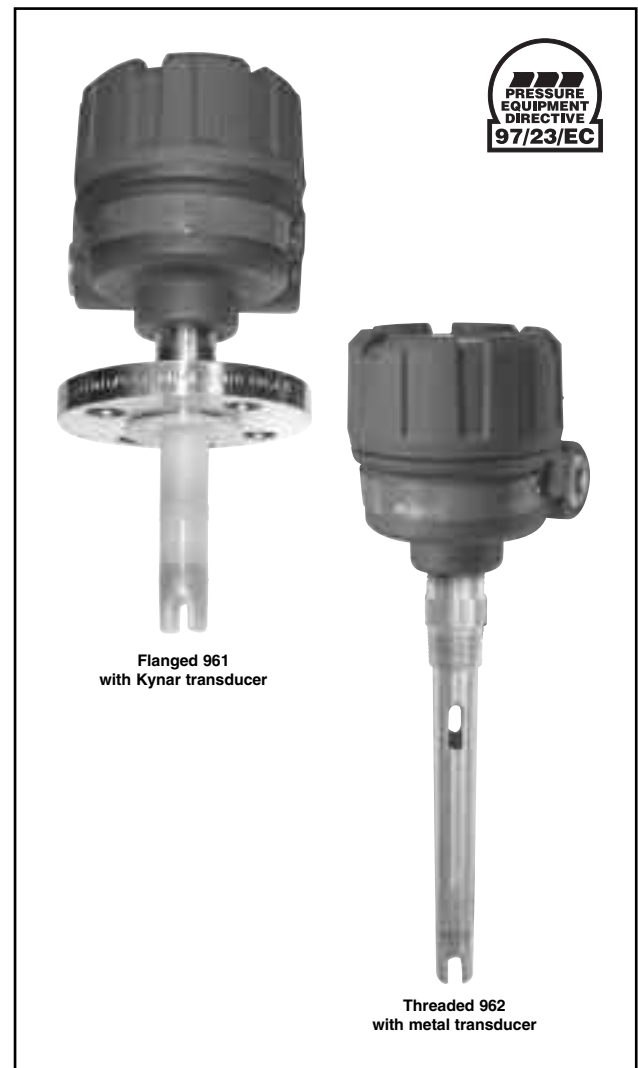

AGENCY APPROVALS

Agency	Approval
ATEX ①	II 1G EEx ia II C T5, intrinsically safe II 1/2 G EEx d II C T6, explosion proof
TÜV	WHG §19 (pending)
AIB	VLAREM II - 5.17.7
FM/CSA ②	Non incensive / intrinsically safe / explosion proof
RosTECH/FSTS GOST-K/GGTN-K ②	Russian Authorisation Standards (pending)

① Only for metal transducers.

② Consult factory for correct model numbers

PRINCIPLE OF OPERATION

The Echotel 961/962 operates on a two crystal pulsed or "transmit-receive" principle which applies a high frequency electronic burst to the transmit crystal. The signal is then converted into ultrasonic energy and transmitted across the sensing gap towards the receiver crystal. When there is air

in the gap, the high frequency ultrasonic energy will be attenuated, thereby not allowing the energy to be received. When there is liquid in the gap, the ultrasonic energy will propagate across the gap and the current shift or relay output will indicate a reception of the signal.

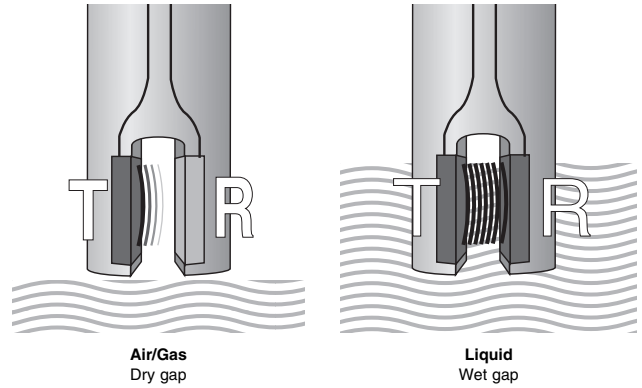
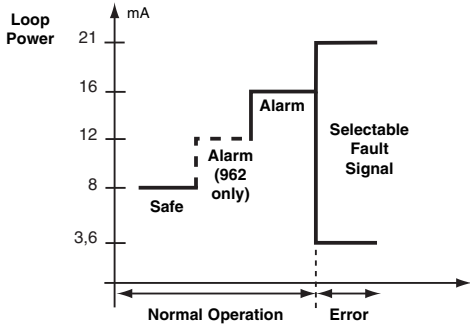

MOUNTING

Ambient temperature: -40°C (-40°F) to +70°C (+160°F)

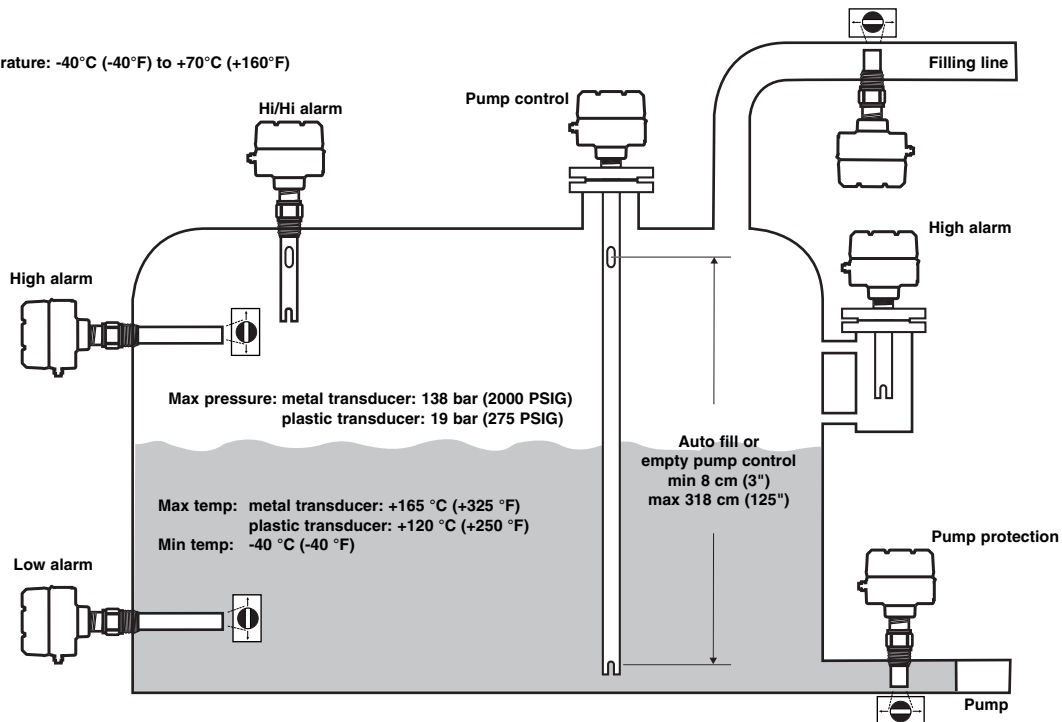

APPLICATIONS

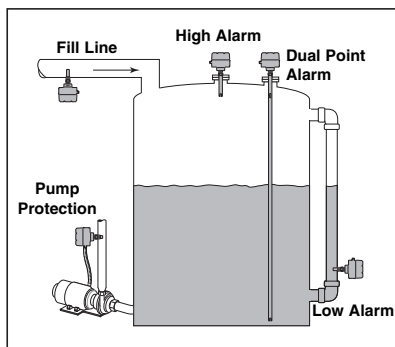

High/Low Level Alarm

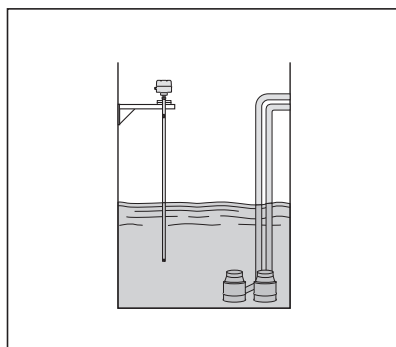

Pump Control



Sanitary

PHYSICAL/FUNCTIONAL SPECIFICATIONS

Description		Specification
Input Voltage	mA - version	2 wire loop powered, 11 - 35 V DC
	Relay - version	102 - 265 V AC or 18 - 32 V DC
Power Consumption		< 3 Watt (relay version) – < 1 Watt (mA version)
Signal Output	mA - version	961: 8 mA (safe), 16 mA (alarm) ± 1 mA 962: 8 mA (safe), 12 mA (lower gap alarm), 16 mA (upper gap alarm) ± 1 mA 961/962: ≤ 3,6 or ≥ 21 mA error signal
	Relay - version	961: one 5 A DPDT relay, 962: two 5 A SPDT relays 961/962: one 5 A SPDT malfunction relay
Indication		LED's for process alarm status, malfunction (error of transducer, electronics or electrical noise interference) and wet/dry status of transducer (961 with relay only)
Selftest	Automatic	Continuously verifies electronics, transducer and noise interference
	Manual	Via pushbutton for checking alarm output(s) and error output/function.
Housing material		IP66, cast aluminium or cast stainless steel
Approvals		ATEX, II 1 G, EEx ia IIC T5, intrinsically safe (current shift units with metal transducers) ATEX, II 1/2 G, EEx d IIC T6, explosion proof (units with metal transducers) FM/CSA, non incandive, intrinsically safe and explosion proof Overfill prevention TÜV - WHG § 19 (pending) / VLAREM II 5.17.7
SIL (Safety Integrity Level)		Functional safety to SIL 2/3 in accordance to IEC 61508 – SFF > 90 % – full FMEDA report and declaration sheets available upon request
Electrical data		U _i = 28,4 V, I _i = 94 mA, P _i = 0,67 W (mA version)
Equivalent data		C _i = 10,4 nF (961) / C _i = 60 nF (962), L _i = 400 µH (mA version)
Shock/Vibration		ANSI/ISA-S71.03 Class SA1 (shock), ANSI/ISA-S71.03 Class VC2 (vibration)
Net Weight		1.5 kg (3 lbs) with 50 mm (2") transducer

PERFORMANCE SPECIFICATIONS

Description	Specification
Response time	0,5 s typical
Repeatability	± 2 mm (0.078")
Ambient Temperature	-40 °C up to +70 °C (-40 °F to +160 °F)
Humidity	0-99 %, non condensing
Electromagnetic Compatibility	Meets CE requirements (EN 61000-6-4, EN 61000-6-2) and NAMUR NE 21

TRANSDUCERS SPECIFICATIONS

Description	Plastic transducers	Metal transducers
Transducer materials	CPVC Kynar® (PVDF)	316/316L SST (1.4401/1.4404) Hastelloy® C (2.4819) Monel® (2.4360)
Mounting	Threaded (NPT) – Flanged (ANSI - EN/DIN)	
Actuation length	From 50 mm up to 3300 mm (2" up to 130")	From 30 mm up to 3300 mm (1" up to 130")
Process temp. (consult temp/press. graphs)	-40 °C up to 120 °C (-40 °F up to 250 °F) – PVDF -40 °C up to 80 °C (-40 °F up to 180 °F) – CPVC	-40 °C up to +165 °C (-40 °F up to +325 °F) -80 °C up to +105 °C (-110 °F up to +220 °F) – 316/316L SST
Max pressure (consult temp/press. graphs)	14 bar @ +40 °C (200 psi @ 40 °F) for NPT threaded units	138 bar (2000 psi): ≤ 5 cm transducers – except Monel 103 bar (1500 psi): > 5 cm transducers – except Monel 83 bar (1200 psi) for Monel transducers
	Flanged models are downrated to the design pressure of the selected flange	
Max viscosity	10.000 cP	

ELECTRONICS



Loop powered 961



Line powered 961

FUNCTIONS

Adjustable time delay:

The Echotel 961/962 provides a fast response time of typically < 1s. In applications with turbulent or boiling surfaces, this may lead to scattering of the output. For these applications, the user can adjust via a potentiometer a time delay from 1 to 45 s and avoid scatter of the output.

Pushbuttons for manual check: The alarm output and the error signal of the Echotel 961/962 can be manually checked via pushbuttons. For loop powered units, the loop test pushbutton will sequentially check the shift of loop current. For relay operated units, the level test pushbutton will make the relay change from energized to de-energized status or vice versa. Pressing the fault/malfunction pushbutton stops all transmit pulses, which simulates an electronics failure, and tests the selected output signal.

LED identification:

Alarm LEDs report alarm status. For 962 models, the alarm status per gap is reported. A separate LED on the 961 model (with relay output), reports independently from the alarm status, whether the gap is immersed or not.

Fault LED reports a malfunction of the unit. The blinking sequence of the LED identifies the failure (electronics, transducer or electrical noise interference).

Malfunction LED (only for units with relay) confirms that the malfunction relay is energized in normal operation

Pump Control (only 962 model with relays):

The model 962 with relays can be set for pump control or level alarm. By selecting pump control (PC), the unit will latch its 2 SPDT relays and provide automatic fill or drain function between its 2 setpoints. In level alarm mode (LC), the unit will detect either high and high-high or low and low-low level alarm.

Selectable error signal:

The error signal of loop powered units (961/962) can be set for either 3.6 or 21 mA. The separate malfunction relay of the 961 can be set for independent or joint operation with the alarm relay. The 962 with relays will always report a malfunction via the alarm relay.

ELECTRICAL WIRING

Loop powered

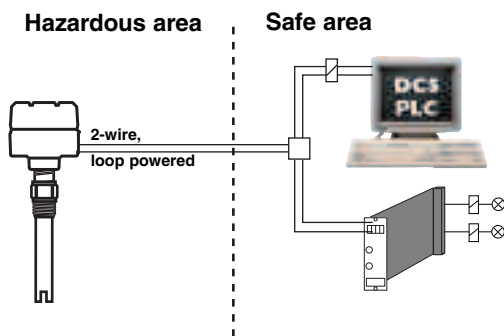

Line powered

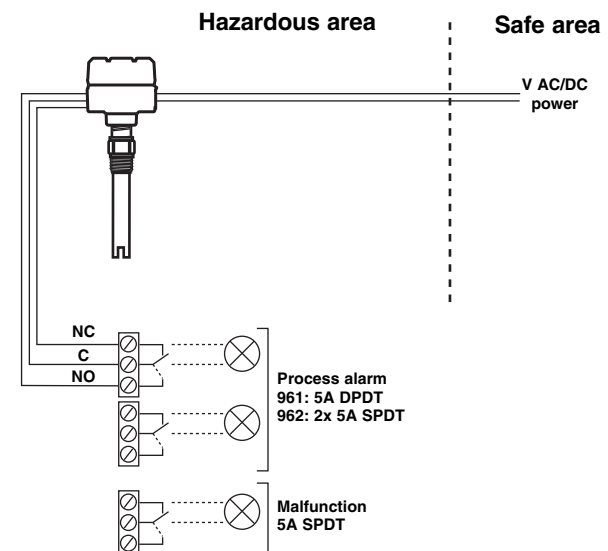

EXPEDITE SHIP PLAN (ESP)

Several Echotel 961/962 units are available for quick shipment, within max. 3 weeks after factory receipt of purchase order, through the Expedite Ship Plan (ESP).

Models covered by ESP service are conveniently grey coded in the selection data charts.

To take advantage of ESP, simply match the colour grey model number codes (standard dimensions apply).

ESP service may not apply to orders of ten units or more. Contact your local representative for lead times on larger volume orders, as well as other products and options.

ECHOTEL 961 / 962 – ELECTRONICS

Selection data

A complete measuring system consists of:

1. Echotel 961/962 electronics
2. Echotel 9M1/9M2 transducer

1. Order code for Echotel 961/962 electronics

BASIC MODEL NUMBER

9 6 1	Echotel 961 electronics for single setpoint 9M1 transducers
9 6 2	Echotel 962 electronics for dual setpoint 9M2 transducers

INPUT POWER

5 0 A	2-wire loop powered with current shift output
2 D A	18 - 32 V DC line powered with 5 A gold flash relay(s)
7 D A	102 - 265 V AC line powered with 5 A gold flash relay(s)

ACCESSORIES

0	Blind housing cover
1	Housing cover with glass window (for aluminium housings only)

MOUNTING

0	Integral mount electronics
---	----------------------------

APPROVALS

Units with current shift output (961/962 - 50 A)

A	ATEX II 1 G EEx ia IIC T5, intrinsically safe
1	General purpose (& I.S. FM/CSA)

Units with relay output (961/962 - xDA)

C	ATEX II 1/2 G EEx d IIC T6, explosion proof
3	General purpose (& FM/CSA explosion proof)

HOUSING / CABLE ENTRY

1	Cast aluminium housing with M20 x 1,5 cable entry (2 entries – one plugged)
0	Cast aluminium housing with 3/4" NPT cable entry (2 entries – one plugged)
3	Cast stainless steel with M20 x 1,5 cable entry (2 entries – one plugged)
2	Cast stainless steel with 3/4" NPT cable entry (2 entries – one plugged)

9 6 A 0 complete order code for Echotel 961/962 electronics

DIMENSIONS IN mm (inches)

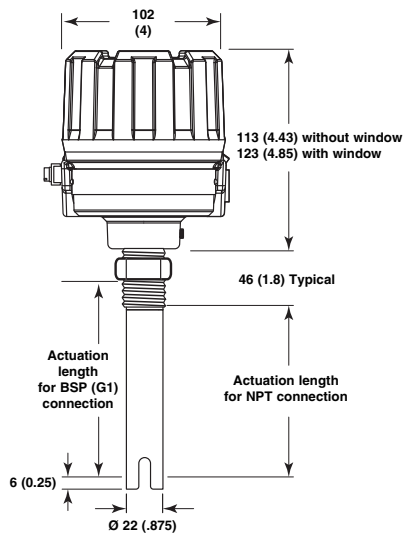

Threaded connection

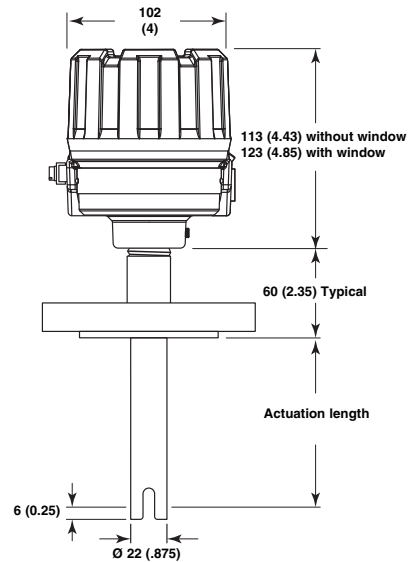

Flanged connection

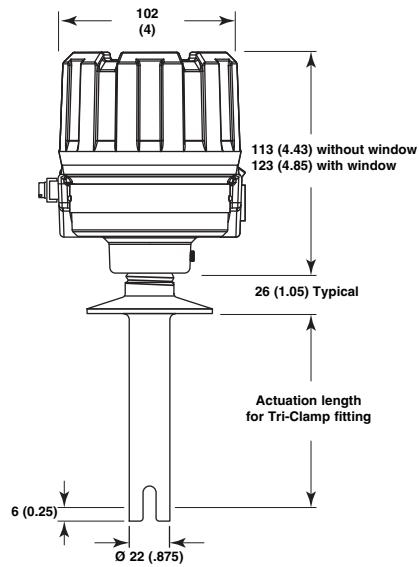

Tri-Clamp® 16 AMP fitting

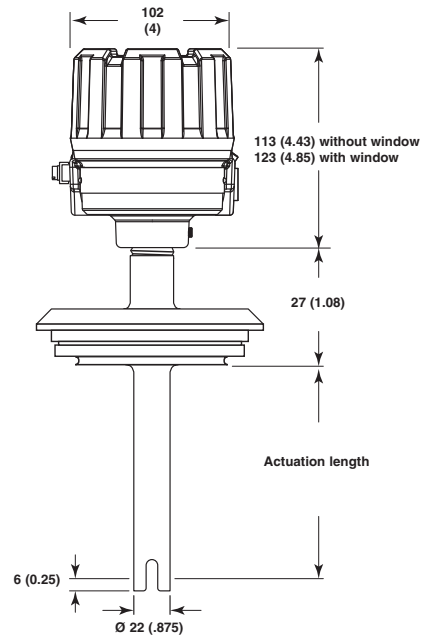

Varivent flange

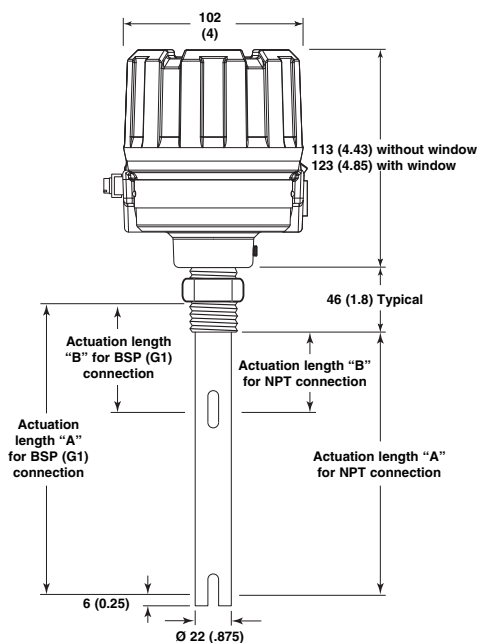

Threaded connection

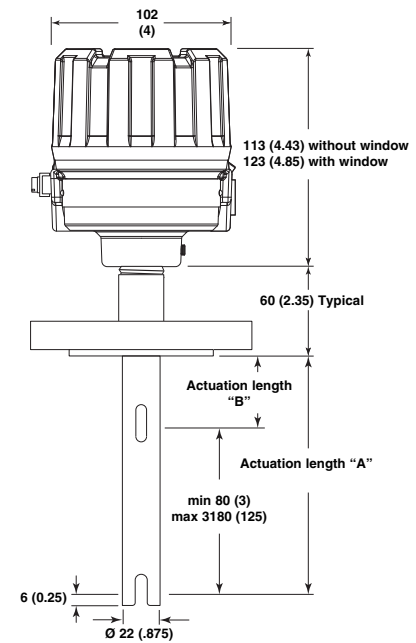

Flanged connection

ECHOTEL 961/962 transducers

2. Order code for Echotel 961/962 transducer

BASIC MODEL NUMBER

9 M 1	Echotel 961 transducer with single setpoint
9 M 2	Echotel 962 transducer with dual setpoints

TRANSDUCER MATERIALS (use only metal transducers for hazardous area)

A	316/316 L (1.4401/1.4404) stainless steel	for 961/962 ^①
B	Hastelloy C (2.4819)	for 961
C	Monel (2.4360)	for 961
P	CPVC	for 961/962
R	Kynar (PVDF)	for 961
S	316/316L (1.4401/1.4404) with 0,5 µm (Ra 20) sanitary finish	for 961

^① Low temperature sensor (min -80 °C) is only available in 316/316L SST for 961 units

PROCESS CONNECTION

Threaded (Plastic transducers are only available with 3/4" NPT connection)

1 1	threaded 3/4" NPT connection
2 1	threaded 1" NPT connection
2 2	threaded G1 (1" BSP) connection

ANSI RF Flanges

2 3	1"	150 lbs	Raised face
2 4	1"	300 lbs	Raised face
2 5	1"	600 lbs	Raised face
3 3	1 1/2"	150 lbs	Raised face
3 4	1 1/2"	300 lbs	Raised face
3 5	1 1/2"	600 lbs	Raised face
4 3	2"	150 lbs	Raised face
4 4	2"	300 lbs	Raised face
4 5	2"	600 lbs	Raised face

CPVC flanges for CPVC transducers.
Kynar clad SST flanges for Kynar transducers
Use only 150 lbs / PN 16 order codes for plastic transducers

EN/DIN Flanges

B A	DN 25	PN 16	EN 1092-1 Type A
B B	DN 25	PN 25/40	EN 1092-1 Type A
B C	DN 25	PN 63/100	EN 1092-1 Type B2
C A	DN 40	PN 16	EN 1092-1 Type A
C B	DN 40	PN 25/40	EN 1092-1 Type A
C C	DN 40	PN 63/100	EN 1092-1 Type B2
D A	DN 50	PN 16	EN 1092-1 Type A
D B	DN 50	PN 25/40	EN 1092-1 Type A
D D	DN 50	PN 63	EN 1092-1 Type B2
D E	DN 50	PN 100	EN 1092-1 Type B2

Sanitary (use only in combination with sanitary transducer material code "S")

3 T	1" / 1 1/2" Tri-Clamp® 16 AMP fitting
4 T	2" Tri-Clamp® 16 AMP fitting
V V	DN 65 Varivent® flange

SENSOR TYPE

A	Standard sensor: min -40 °C / max +165 °C (-40 °F / +325 °F)
C	Low temperature sensor: min -80 °C / max +105 °C (-110 °F / +220 °F) – only for 961 with 316/316L sensor

ACTUATION LENGTH – specify in cm (per 0.39") increments

Total insertion length = actuation length + 6 mm (0.25")

9M1 transducers - ESP

0 0 3	30 mm (1.2") with NPT process connection only
0 0 4	40 mm (1.5")
0 1 0	100 mm (4")
0 2 5	250 mm (10")

9M1 transducers - selectable

0 0 3	Min 30 mm (1.2")
0 0 5	Min 50 mm (2") - for 1" BSP (G1) / flanged and sanitary units
3 3 0	Max 3300 mm (130")

9M2 transducers "A" length, specify "B" length separately

0 1 3	Min 130 mm (5.1")
0 1 5	Min 150 mm (5.9") - for 1" BSP (G1) / flanged units
3 3 0	Max 3300 mm (130")

9	M								
---	---	--	--	--	--	--	--	--	--

complete order code for Echotel 961/962 transducers

PRESSURE/TEMPERATURE RATINGS

Kynar Transducer Ratings

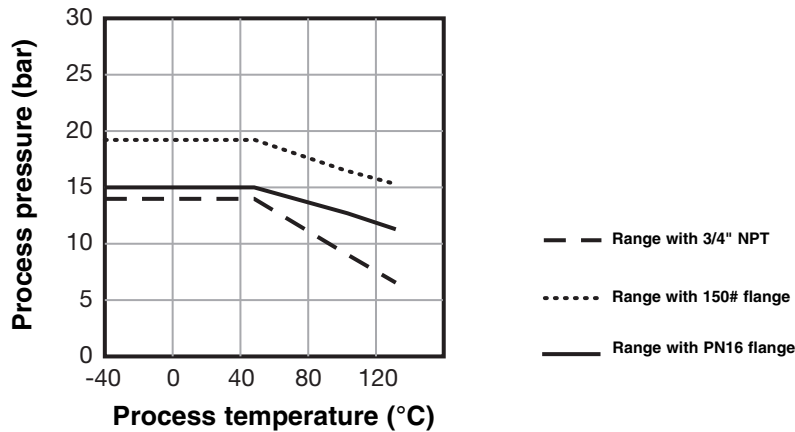

CPVC Transducer Ratings

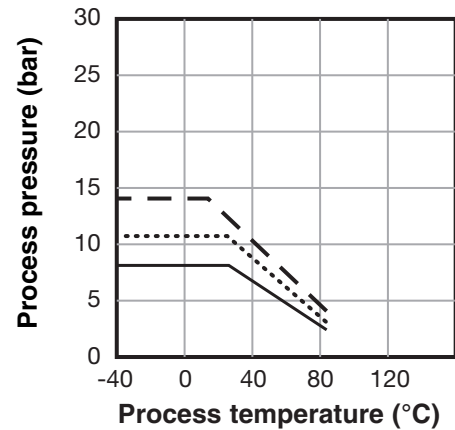

Metal Transducer Ratings

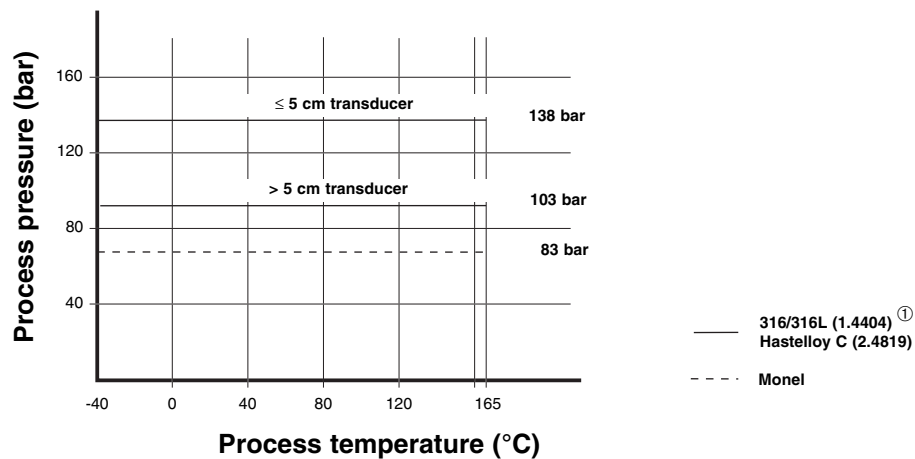

① For low temperature sensor: from -80 °C up to +105 °C



QUALITY ASSURANCE - ISO 9001:2000

THE QUALITY ASSURANCE SYSTEM IN PLACE AT MAGNETROL GUARANTEES THE HIGHEST LEVEL OF QUALITY DURING THE DESIGN, THE CONSTRUCTION AND THE SERVICE OF CONTROLS. OUR QUALITY ASSURANCE SYSTEM IS APPROVED AND CERTIFIED TO ISO 9001:2000 AND OUR TOTAL COMPANY IS COMMITTED TO PROVIDING FULL CUSTOMER SATISFACTION BOTH IN QUALITY PRODUCTS AND QUALITY SERVICE.

PRODUCT WARRANTY

ALL MAGNETROL ELECTRONIC AND ULTRASONIC LEVEL CONTROLS ARE WARRANTED FREE OF DEFECTS IN MATERIALS AND WORKMANSHIP FOR ONE FULL YEAR FROM THE DATE OF ORIGINAL FACTORY SHIPMENT. IF RETURNED WITHIN THE WARRANTY PERIOD; AND, UPON FACTORY INSPECTION OF THE CONTROL, THE CAUSE OF THE CLAIM IS DETERMINED TO BE COVERED UNDER THE WARRANTY; THEN, MAGNETROL INTERNATIONAL WILL REPAIR OR REPLACE THE CONTROL AT NO COST TO THE PURCHASER (OR OWNER) OTHER THAN TRANSPORTATION. MAGNETROL SHALL NOT BE LIABLE FOR MISAPPLICATION, LABOR CLAIMS, DIRECT OR CONSEQUENTIAL DAMAGE OR EXPENSE ARISING FROM THE INSTALLATION OR USE OF THE EQUIPMENT. THERE ARE NO OTHER WARRANTIES EXPRESSED OR IMPLIED, EXCEPT, SPECIAL WRITTEN WARRANTIES COVERING SOME MAGNETROL PRODUCTS.



BULLETIN N°: BE 51-137.1
EFFECTIVE: FEBRUARY 2007
SUPERSEDES: March 2006

UNDER RESERVE OF MODIFICATIONS

BENELUX	Heikensstraat 6, 9240 Zele, België Tel. +32 (0)52.45.11.11 • Fax. +32 (0)52.45.09.93 • E-Mail: info@magnetrol.be
DEUTSCHLAND	Alte Ziegelei 2-4, D-51491 Overath Tel. 02204 / 9536-0 • Fax. 02204 / 9536-53 • E-Mail: vertrieb@magnetrol.de
FRANCE	40 - 42, rue Gabriel Péri, 95130 Le Plessis Bouchard Tél. 01.34.44.26.10 • Fax. 01.34.44.26.06 • E-Mail: magnetrolfrance@magnetrol.fr
ITALIA	Via Aresè 12, I-20159 Milano Tel. (02) 607.22.98 (R.A.) • Fax. (02) 668.66.52 • E-Mail: mit.gen@magnetrol.it
UNITED KINGDOM	Unit 1 Regent Business Centre, Jubilee Road Burgess Hill West Sussex RH 15 9TL Tel. (01444) 871313 • Fax (01444) 871317 • E-Mail: sales@magnetrol.co.uk
INDIA	E-22, Anand Niketan, New Delhi - 110 021 Tel. 91 (11) 41661840 • Fax 91 (11) 41661843 • E-Mail: info@magnetrolindia.com

www.magnetrol.com

OUR NEAREST REPRESENTATIVE