

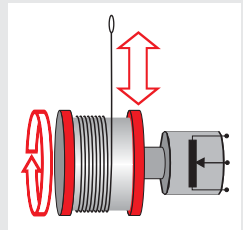

More Precision.

wire**SENSOR**

Draw wire sensors / CET / String pots



wireSENSOR Series P200



Robust sensor design
Long range sensor - up to 50,000 mm
Various digital interfaces

The P200 series are specially designed for industrial applications in elevator engineering, crane systems and high bay warehouses. The rugged housing and solid, high quality components guarantee high operational reliability and a long service life even in difficult industrial environments.

Model P200

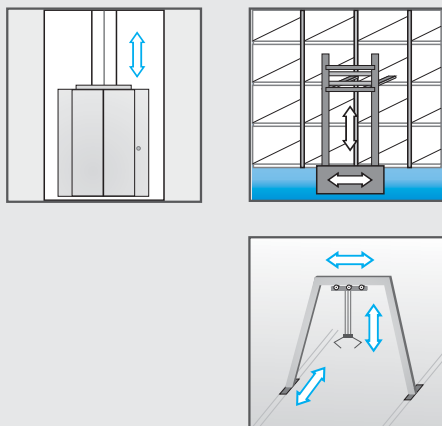
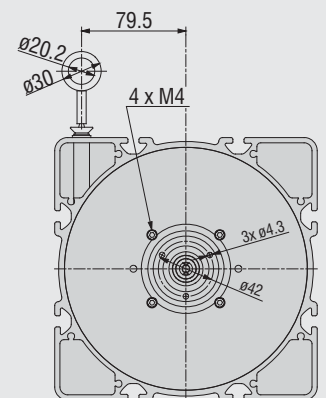
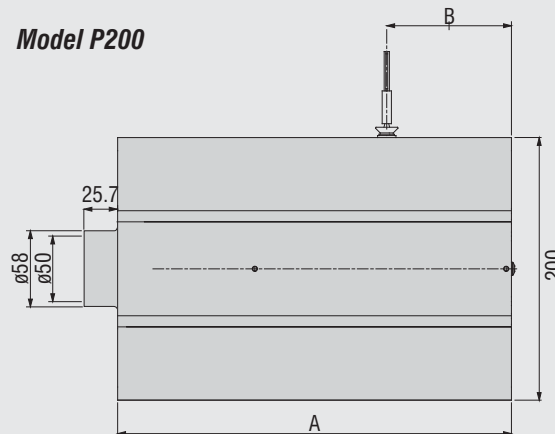

Model P200-HTL/TTL

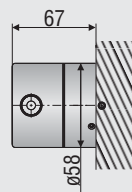

Model P200-SSI

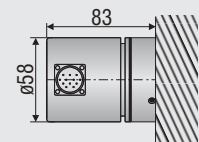

Model P200-CO/PB

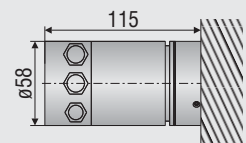

Measuring range	A	B
30000	268	75
40000	300	95
50000	333.5	95

Dimensions in mm, not to scale. Please ask for detailed reference drawings.

Model	WDS-30000-P200	WDS-40000-P200	WDS-50000-P200
Measuring range	30000 mm	40000 mm	50000 mm
Output	HTL, TTL, SSI, PB, CO		
Travel per encoder revolution	500 mm		
Linearity ± 0.01 % FSO	3 mm	4 mm	5 mm
Resolution	HTL, TTL		
	0.167 mm (6 pulses/mm)		
SSI, PB, CO		0.061 mm	
Temperature range	-20 ... +80 °C		
Sensor element	incremental-/absolute encoder		
Material	housing: aluminum		
	draw wire: coated polyamid stainless steel (ø 0.8 mm)		
Wire mounting	eyelet		
Sensor mounting	slot nuts		
Wire acceleration	2 g		
Wire retraction force (min)	12 N	11 N	11 N
Wire extension force (max)	22 N	22 N	24 N
Protection class	IP 65		
Electrical connection	output HTL, TTL	integral cable, radial, 1 m long	
	output SSI	connector, radial, 12-pin	
	output PB, CO	bus cover	
Weight	appr. 10 kg	appr. 11 kg	appr. 12 kg

FSO = Full Scale Output

Specifications for digital outputs page 32 and continuing.

Article description

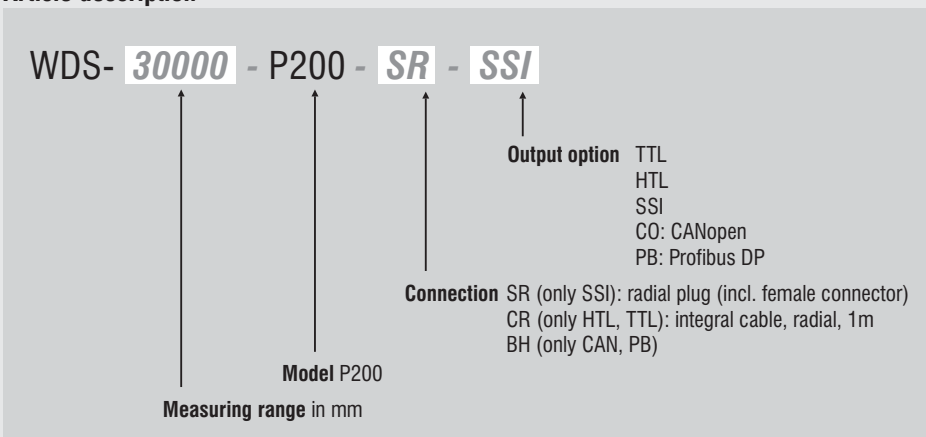

wireSENSOR Accessories and mounting

WE-x-M4, WE-x-Clip Wire extension x=length

TR1-WDS Pulley wheel, adjustable

TR3-WDS Pulley wheel, fixed

GK1-WDS Attachment head for M4

MH1-WDS Magnetic holder for wire mounting

MH2-WDS Magnetic holder for sensor mounting

MT-60-WDS Mounting clamp for WDS-P60

FC8 Female connector for WDS, 8-pin

FC8/90 Female connector 90° for WDS, 8-pin

PC 3/8 Sensor cable, length 3 m

PS 2010 Power supply (chassis mounting 35 x 7.5 mm); input 120/230 VAC; output 24 VDC / 2.5 A; L/B/H 120 x 20 x 40 mm

WDS-MP60 Mounting plate for P60 sensors

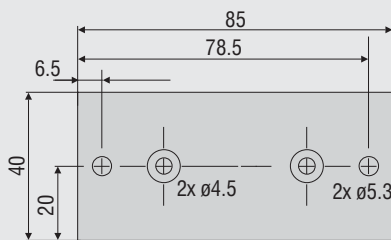

Mounting plate WDS-MP60

Application example with accessories

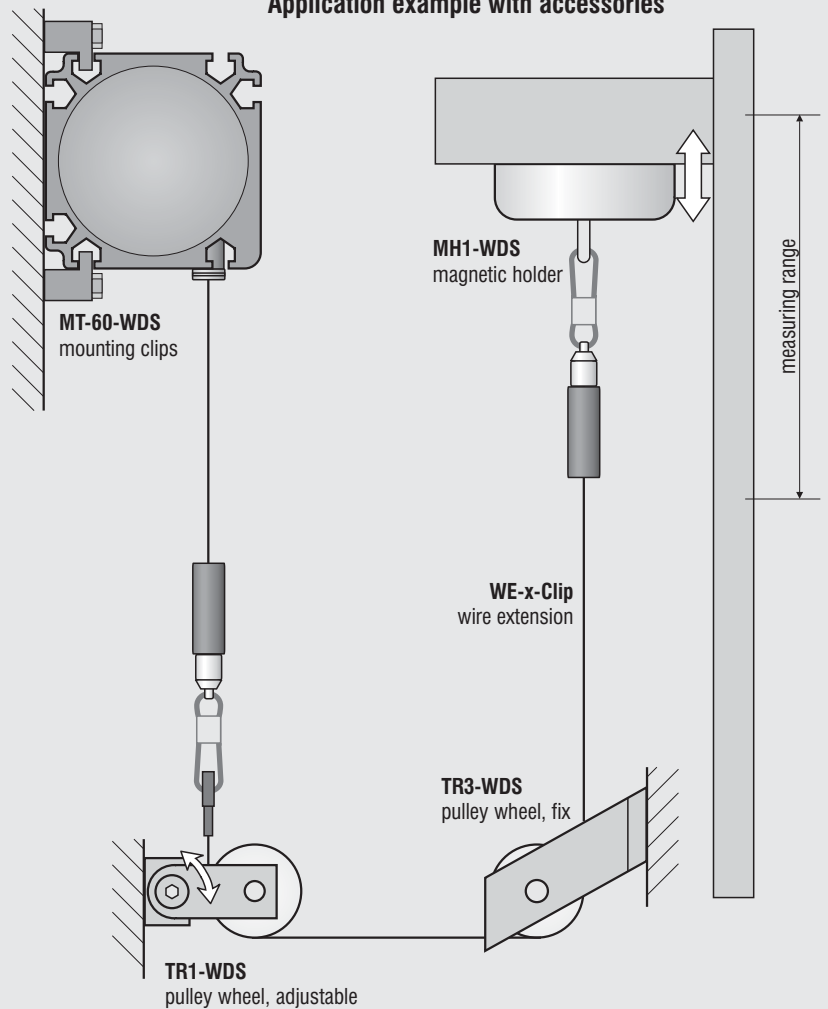

Installation information:

Wire attachment: The free return of the measurement wire is not permissible and it is essential that this is avoided during installation.

Wire exit angle:

When mounting a draw-wire displacement sensor, a straight wire exit ($\pm 3^\circ$ tolerance) must be taken into account. If this tolerance is exceeded, increased material wear on the wire and at the wire aperture must be expected.

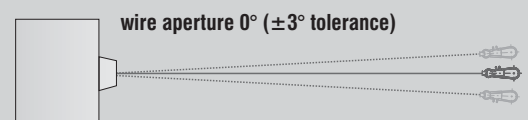

wireSENSOR

Electrical data analog

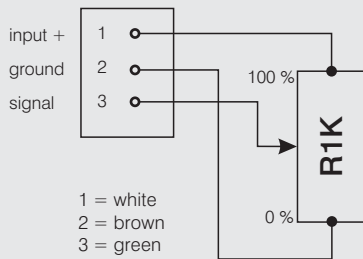

Potentiometric output (P)	
Supply voltage	max. 32 VDC at 1 kOhm / 1 W max
Resistance	1 kOhm \pm 10 % (potentiometer)
Temperature coefficient	\pm 0.0025 % FSO/ $^{\circ}$ C
Sensitivity	depends on measuring range individually shown on test report

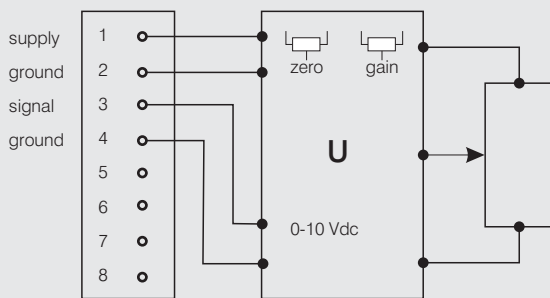

Voltage output (U)	
Supply voltage	14 ... 27 VDC (non stabilized)
Current consumption	30 mA max
Output voltage	0 ... 10 VDC option 0 ... 5 / \pm 5 V
Load impedance	>5 kOhm
Signal noise	0.5 mV _{eff}
Temperature coefficient	\pm 0.005 % FSO/ $^{\circ}$ C
Electromagnetic compatibility (EMC)	EN 50081-2 EN 50082-2
Adjustment ranges	
Zero	\pm 20 % FSO
Sensitivity	\pm 20 %

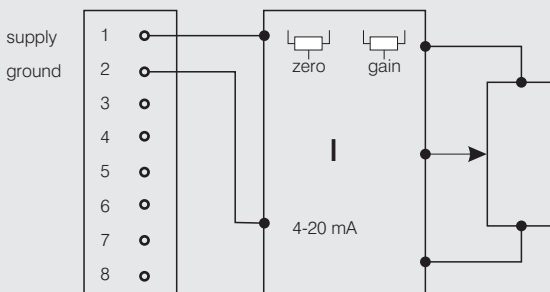

Current Output (I)	
Supply voltage	14 ... 27 VDC (non stabilized)
Current consumption	35 mA max
Output current	4 ... 20 mA
Load	<600 Ohm
Signal noise	<1.6 μ A _{eff}
Temperature coefficient	\pm 0.01 % FSO/ $^{\circ}$ C
Electromagnetic compatibility (EMC)	EN 50081-2 EN 50082-2
Adjustment ranges	
Zero	\pm 18 % FSO
Sensitivity	\pm 15 %

wireSENSOR

Absolute encoder output specifications: SSI

Contact description

1 UB	Encoder power supply connection.
2 GND	Encoder ground connection. The voltage drawn to GND is UB.
3 Pulse +	Positive SSI pulse input. Pulse + forms a current loop with pulse -. A current of approx. 7 mA in direction of Pulse + input generates a logical 1 in positive logic.
4 Data +	Positive, serial data output of the differential line driver. A High level at the output corresponds to logical 1 in positive logic.
5 ZERO	Zero setting input for setting a zero point at any desired point within the entire resolution. The zeroing process is triggered by a High pulse (pulse duration ≥ 100 ms) and must take place after the rotating direction selection (UP/DOWN). For maximum interference immunity, the input must be connected to GND after zeroing.
6 Data -	Negative, serial data output of the differential line driver. A High level at the output corresponds to logical 0 in positive logic.
7 Pulse -	Negative SSI pulse input. Pulse - forms a current loop with pulse +. A current of approx. 7 mA in direction of Pulse - input generates a logical 0 in positive logic.
8 / 10 $\overline{\text{DATAVALID}}$ $\overline{\text{DATAVALID MT}}$	Diagnosis outputs $\overline{\text{DV}}$ and $\overline{\text{DV MT}}$ Jumps in data word, e.g. due to defective LED or photoreceiver, are displayed via the $\overline{\text{DV}}$ output. In addition, the power supply of the multiturn sensor unit is monitored and the $\overline{\text{DV MT}}$ output is set when a specified voltage level is dropped below. Both outputs are Low-active, i.e. are switched through to GND in the case of an error.
UP/DOWN	UP/DOWN counting direction input. When not connected, this input is on High. UP/DOWN-High means increasing output data with a clockwise shaft rotating direction when looking at the flange. UP/DOWN-Low means increasing values with a counter-clockwise shaft rotating direction when looking at the flange.
11 / 12	Not in use

Pin assignment

Pin	Cable color	Assignment
1	brown	UB
2	black	GND
3	blue	Pulse +
4	beige	Data +
5	green	ZERO
6	yellow	Data -
7	violet	Pulse -
8	brown/yellow	$\overline{\text{DATAVALID}}$
9	pink	UP/DOWN
10	black/yellow	$\overline{\text{DATAVALID MT}}$
11	-	-
12	-	-

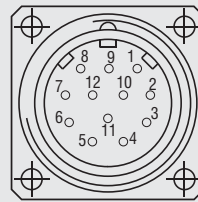

Please use leads twisted in pairs for extension cables.

Inputs

Control signals UP/DOWN and Zero

Level High	> 0.7 UB
Level Low	< 0.3 UB

Connection: UP/DOWN input with 10 kohms to UB, zeroing input with 10 kohms to GND.

SSI pulse
Optocoupler inputs for electrical isolation

Outputs

SSI data	RS485 driver
Diagnostic outputs	
Push-pull outputs are short-circuit-proof	
Level High	> UB - 3.5 V (with I = -20 mA)
Level Low	< 0.5 V (with I = 20 mA)

wireSENSOR

Absolute encoder output specifications: CANopen

CANopen features

Bus protocol	CANopen
Device profile	CANopen - CiA DSP 406, V 3.0
CANopen Features	Device Class 2, CAN 2.0B
Operating modes (with SDO progr.)	<p>Polling Mode (asynch, via SDO)</p> <p>Cyclic Mode (asynch-cyclic) The encoder cyclically sends the current process actual value without a request by a master. The cycle time can be parameterized for values between 1 and 65535 ms. Synch Mode (synch-cyclic) The encoder sends the current actual process value after receiving a synch telegram sent by a master. The synch counter in the encoder can be parameterized so that the position value is not sent until after a defined number of synch telegrams.</p> <p>Acyclic Mode (synch-acyclic)</p>
Preset value	With the "Preset" parameter the encoder can be set to a desired actual process value that corresponds to the defined axis position of the system. The offset value between the encoder zero point and the mechanical zero point of the system is saved in the encoder.
Rotating direction	With the operating parameter the rotating direction in which the output code is to increase or decrease can be parameterized. Scaling The steps per revolution and the total revolution can be parameterized.
Diagnosis	<p>The encoder supports the following error messages:</p> <ul style="list-style-type: none"> - Position and parameter error - Lithium cell voltage at lower limit (Multiturn)
Default setting	50 kbit/s, node number 0

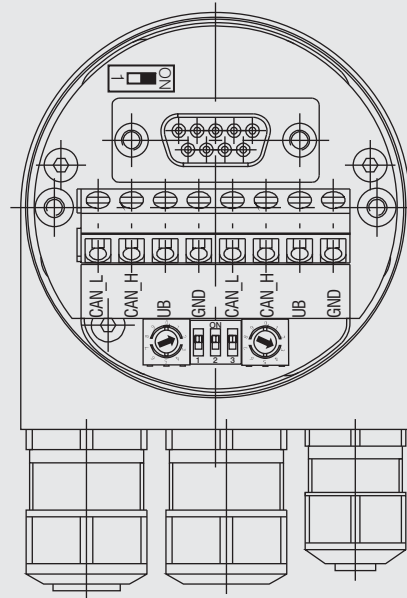

Setting of terminating Resistor for CANopen



ON = Last user
OFF = User X

Setting CANopen baud rate

Baud rate	Setting Dip Switch		
	1	2	3
10 kBit/s	OFF	OFF	OFF
20 kBit/s	OFF	OFF	ON
50 kBit/s	OFF	ON	OFF
125 kBit/s	OFF	ON	ON
250 kBit/s	ON	OFF	OFF
500 kBit/s	ON	OFF	ON
800 kBit/s	ON	ON	OFF
1 MBit/s	ON	ON	ON

Contact description CANopen

CAN_L	CAN Bus Signal (dominant Low)
CAN_H	CAN Bus Signal (dominant High)
UB	Supply voltage 10...30 VDC
GND	Ground contact for UB

(Terminals with the same designation are internally interconnected)

Settings of user address for CANopen

Address can be set with rotary switch. Example: User address 23

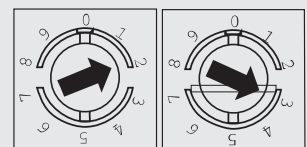

wireSENSOR

Absolute encoder output specifications: Profibus

Profibus-DP features

Bus protocol	Profibus-DP
Profibus features	Device Class 1 and 2
Data exch. functions	Input: Position value Additional parameterized speed signal (readout of the current rotary speed) Output: Preset value
Preset value	With the "Preset" parameter the encoder can be set to a desired actual value that corresponds to the defined axis position of the system.
Parameter functions	Rotating direction: With the operating parameter the rotating direction for which the output code is to increase or decrease can be parameterized.
Scaling:	The steps per revolution and the total revolution can be parameterized.
Diagnosis	The encoder supports the following error messages: - Position error - Lithium cell voltage at lower limit (Multiturn)
Default setting	User address 00

Settings of user address for Profibus-DP

Address can be set with rotary switch. Example: User address 23

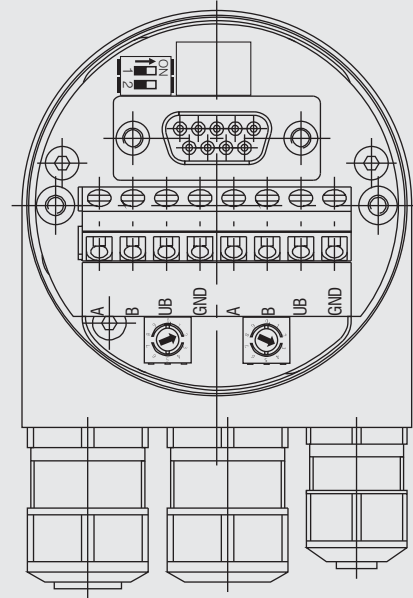
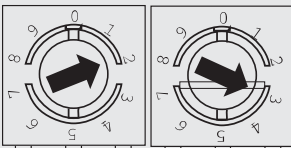

Settings of terminating resistors for Profibus-DP



ON = last user
OFF = user X

Contact description Profibus-DP

A	A negative serial data line
B	Positive serial data line
UB	Supply voltage 10...30 VDC
GND	Ground contact for UB

(Terminals with the same designation are internally interconnected)

wireSENSOR

Output specifications Incremental-encoder

Signal output

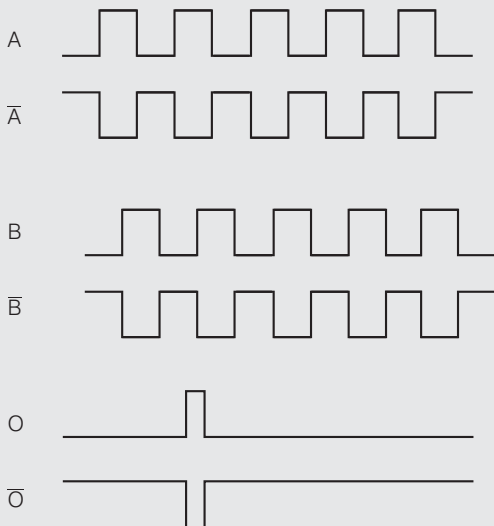

Output TTL Linedriver (5 VDC)

Level High	$\geq 2.5 \text{ V}$	(with $I = -20 \text{ mA}$)
Level Low	$\leq 0.5 \text{ V}$	(with $I = 20 \text{ mA}$)
Load High	$\leq 20 \text{ mA}$	
Output	A, \bar{A} , B, \bar{B} , O	

Output HTL Push-pull (10 ... 30 VDC)

Level High	$\geq UB - 3 \text{ V}$	(with $I = -20 \text{ mA}$)
Level Low	$\leq 1.5 \text{ V}$	(with $I = 20 \text{ mA}$)
Load	$\leq 40 \text{ mA}$	
Output	A, \bar{A} , B, \bar{B} , O	

Output E Push-pull (5 VDC)

Level High	$UB - 2.5 \text{ V}$
Level Low	$\leq 0.5 \text{ V}$
Load	$\leq 50 \text{ mA}$
Output	A, B, O

Output E830 Push-pull (8 ... 30 VDC)

Level High	$UB - 3 \text{ V}$
Level Low	$\leq 2.5 \text{ V}$
Load	$\leq 50 \text{ mA}$
Output	A, B, O

Pin assignment TTL, HTL

Pin	Cable color	Assignment
1	pink	B inv.
2	blue	UB Sense
3	red	N (reference pulse)
4	black	N inv. (reference pulse inv.)
5	brown	A
6	green	A inv.
7	-	-
8	grey	B
9	-	-
10	white/green	GND
11	white	GND Sense
12	brown/green	UB

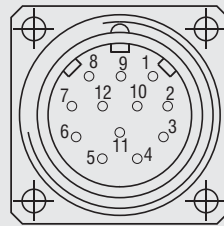

Pin 2 and Pin 12 are internally connected as well as Pin 11 and 10.

For cable length > 10 m twisted pair wires are required.

Connection assignment E, E830

Pin	Cable color	Assignment
-	white	0V
-	brown	+UB
-	green	A
-	-	\bar{A}
-	yellow	B
-	-	\bar{B}
-	grey	O

More Precision.

www.micro-epsilon.com

Sensors and systems

for displacement, position and dimension

Sensors and measurement devices

for non-contact temperature measurement

Measurement systems

for online/offline quality control

MICRO-EPSILON Headquarters

Koenigbacher Str. 15 · 94496 Ortenburg / Germany
Tel. +49 (0) 8542 / 168-0 · Fax +49 (0) 8542 / 168-90
info@micro-epsilon.com

MICRO-EPSILON UK Ltd.

Dorset House, West Derby Road · Liverpool, L6 4BR
Phone +44 (0) 151 260 9800 · Fax +44 (0) 151 261 2480
info@micro-epsilon.co.uk

MICRO-EPSILON USA

8120 Brownleigh Dr. · Raleigh, NC 27617 / USA
Phone +1/919/787-9707 · Fax +1/919/787-9706
info@micro-epsilon.us

