

WMP-227

21.5" Wide Core i Fanless Medical Panel PC



Key Features

- Front full flat resistive touch with IP65 protection
- Fanless operating w/ reliable thermal design
- Anti-bacteria plastic housing and medical 60601-1 3rd edition certification
- 21.5" wide full HD 1920x1080 LCD w/ LED backlight
- Intel low power Core i5 1.6G & Celeron dual core 1.1G processor
- PCI-E/PCI expansion and two mini-PCIe sockets
- Optional internal battery pack for 25 minutes operating
- Optional Wifi, Webcam, Bluetooth and RFID reader
- Customization for LAN/COM/USB isolation, change touch to glass

Main System

CPU	<ul style="list-style-type: none">• Intel Core i5-2467M 1.6GHz (dual core, 3MB cache)• Intel Celeron 847E 1.1GHz (dual core, 2MB cache)• Support BGA1023 socket, 17W TDP
Chipset	Intel BD82HM65 PCH
Graphics	<ul style="list-style-type: none">• Core i5-2467M: Intel HD Graphics HD 3000• Celeron 847E: Intel HD Graphics
Memory	8GB maximum, x 2 DDR3 SODIMM, 1066/1333MHz, 2GB/4GB/8GB
Serial ATA	SATA2 x 2, 300MB/s transfer rate
USB	x 7 (socket), USB 2.0 (x 4 external, x 3 internal)
COM	x 6 (x 2 external, x 4 internal)
Audio	Realtek ALC262 audio codec, 2+2 watts amplifier
LAN	Marvell 88E8071 Gigabit Ethernet x 2
BIOS	<ul style="list-style-type: none">• AMI BIOS, 4M EEPROM• RTC wake up / Wake on LAN / Power on after power failure / PnP / ACPI
Speaker	1.5 watts x 2 (front bottom)

LCD Panel

Size	21.5" wide 16:9
Resolution	Full HD 1920 x 1080
Brightness	250 nits
Contrast	1000:1
Color numbers	16.7M (6-bit x 3 + Hi FRC)
Viewing angle	170 (H) / 160 (V)
Response time	5 ms (R + F)
Backlight	LED, 30,000 hours life time

Touch Panel

Type	Front full flat customized touch panel
Technology	Resistive touch, 5-wire
Light transmittance	> 78% (at 550 nm wavelength)
Hardness	3H
Touch stylus	No limitation
Resolution	4096 x 4096
Life time	35 million activations

Storage & Expansion

HDD	2.5" SATA HDD drive bay x 1 + anti-vibration kit, 160GB / 500GB
Expansion slot	<ul style="list-style-type: none">• PCI-E (x16) x 1 (or PCI x 1)• Card size: 100 x 155 x 18/0.5 mm or 68 x 220 x 18/0.5 mm• Mini PCIe x 2 (52 pin card-edge type)

I/O & Control Keys

USB	USB 2.0 x 4
COM	DB-9 x 2 (RS232, RS232/422/485)
LAN	RJ-45 x 2, Gigabit
Video-out	DVI-I x 1
Audio	Line-out, Microphone-in (3.5 mm phone-jack)
Power input	DC-in x 1, 6V~32V
Control keys	<ul style="list-style-type: none">• Front side, projected capacitive type• Power on/off, Brightness, Audio volume, Backlight on/off, Touch on/off

Power

Power adaptor	External, 100 watts, 90~264V AC in, 12V DC out, medical grade, 1.2m DC cable
Power consumption	65 watts (typical, without any add-ons)
Internal battery (optional)	<ul style="list-style-type: none">• Li-Ion, 28Wh, for 25 minutes operating (approx.), 2S2P• Charge time: 2 hours (system off), 3.5 hours (system on)

Mechanical & Environmental

Housing	<ul style="list-style-type: none">• Front: Full flat design / Touch (standard), Glass (optional)• Rear: Plastic + I/O cover w/ antibacterial treatment• Housing: White . Control key icons: Grey
Color	IP65 – front side
IP rating	Fanless w/ back cover aluminum thermal plate
Cooling	VESA 75 x 75 / 100 x 100 mm
Mounting	Yes, x 1 at bottom
Kensington lock	540 x 375 x 78 mm (W x H x D, w/o stand)
Dimension	7.0 Kg (approximate, w/o power adaptor)
Weight (net)	<ul style="list-style-type: none">• Operating – 0°C~40°C . Storage – -20°C~60°C• Operating & storage – 10%~90%, non-condensing
Temperature	• FCC-B, cUL, CE, VCCI
Humidity	• Medical 60601-1 3 rd edition (EN 60601-1:2006, ANSI/AAMI ES60601-1:2005, CAN/CSA C22.2 No. 60601-1:08)
Regulatory	

WMP-227

21.5" Wide Core i Fanless Medical Panel PC

Outline Dimension

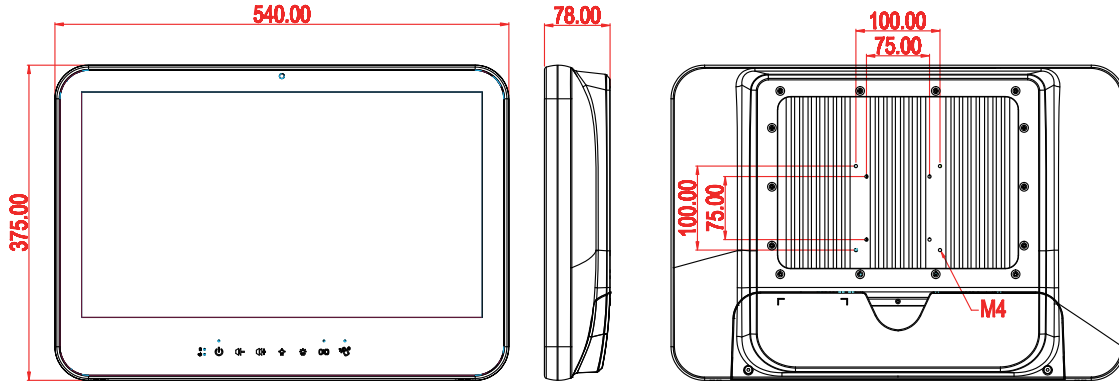

Packaging / Options / Customization

Packaging Options

- System, power adaptor, AC power cord, CD (drivers & manual)
- WLAN 802.11 a/b/g/n mini PCIe module w/ internal antenna x 2
- Bluetooth 2.1 (USB)
- Webcam (2M pixel, USB)
- Battery pack
- RFID reader (13.56Hz, USB)
- Power adaptor w/ 2.4m or 3.6m DC cable
- Anti-bacteria desktop stand (metal, white)

Customization

- Add extra two COM ports
- LAN isolation x 1
- Add COM isolation x 2 module (use expansion slot area)
- Add USB isolation x 1
- Change touch to glass

I/O Connectors

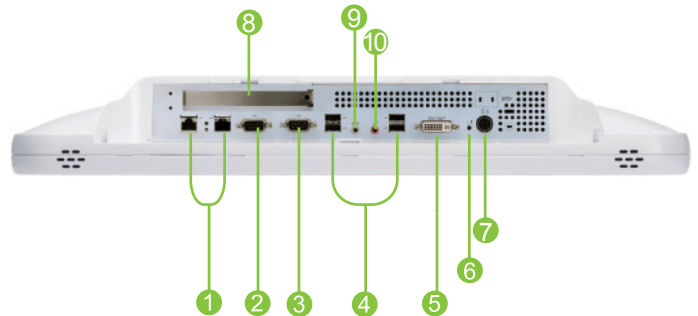

- | | |
|-----------------|-----------------------|
| ① LAN x 2 | ⑥ Reset |
| ② RS232/422/485 | ⑦ DC-in |
| ③ RS232 | ⑧ PCI-E/PCI expansion |
| ④ USB x 4 | ⑨ Line-out |
| ⑤ DVI-I | ⑩ Micropone-in |



Ordering Information

- | | | | |
|--|---------------------------|-----------------------------|----------------------|
| · CPU: Core i5 1.6G / Celeron 1.1G | · Memory: 2G / 4G / 8G | · HDD: 160G / 500G | · Webcam: None / x 1 |
| · Power adaptor: 1.2m / 2.4m / 3.6m DC cable | · Wifi: None / x 1 | · Bluetooth: None / x 1 | |
| · Battery pack: None / x 1 | · RFID reader: None / x 1 | · Desktop stand: None / x 1 | |



Web: www.wincomm.com.tw

Contact: sales_support@wincomm.com.tw

Wincomm Corporation

3F, NO. 14, Prosperity Road II, Science-Based Industrial Park,
Hsinchu, Taiwan 30078, R.O.C

Tel : +886 3 578 0000 Fax: +886 3 578 0295