

Low Power and High Performance 15" Industrial Panel PC with Intel® Core™ i7/i5/i3 Celeron® Mobile Processor



The APP-M150 is designed for control cabinet installation. The correct display size is thus available for every application. And it represents a powerful platform with high speed DDR3 memory, two expansion PCI/PCIe slots and slim type DVD-RW for machine construction and plant engineering applications, for example with the SCADA automation software under Windows 7 and Windows Embedded Standard. The 2-slot add-on APP-M150 complements all types of built-in Touch Panels and is equipped with a 15-inch TFT display. A 100 to 240V AC full range or a 24V DC power supply unit is installed in the PC.

Features

- IP65 compliant front panel
- Robust aluminum front bezel and metal casing
- Supports dual display of DVI, LVDS, VGA
- One slim type drive bay for DVD-RW
- Front access USB connector (S/W control lock)
- Supports 2 x CF slot(one internal), 2 x 2.5" SATA HDD or SSD
- Supports RAID 0,1
- Easy access 2nd CF slot
- Supports PCI x 1 / PCIe x1 or PCI x 2 / PCIe x 2 expansion slot

Specifications

System	CPU	Intel® Core™i7 / i5 / i3 Celeron® QC / DC processors an 989 socket
	Chipset	Intel QM67
	Memory	16GB max (2*204-pin SODIMM)
	Storage	CF card slot, 2 x 2.5" HDD (RAID 0,1) or 1 x SSD
	Ethernet	Intel® 82579LM Gigabit x1 Realtek RTL 8111DL Gigabit x1
	DVD-RW	SATA Slim type muti -ROM
	Expansion Slot	2 x PCI/PCIe card or 2x PCI-e or 2x PCI card
	Dimensions	381(W) x 319(H) x 127(D)
	Weight	7.0 kg
	OS Support	WES 7-WS7E, WES-WS7P, Win XP Embedded, Win XP Pro. Embedded, Linux
LCD Display	Display Type	15 " XGA TFT LCD (LED backlight)
	Max Resolution	1024 x 768 pixels
	Colors	16.2M / 262K
	Luminance	400 cd/m ²
	Contrast Ratio	700 : 1
Touch Screen	Viewing Angel(CR=10)	90°(left),90°(right),90°(up),90°(down)
	Touch Screen Type	5 wire resistive (PCT optional)
I/O Interface	Serial	4 x RS232, 2 x RS232/422/485
	USB	6(Front panel x2, rear x 4)
	Ethernet	2 x 10/100/1000 Mbps (RJ45)
	Audio	ALC262, line-in/line-out/Mic-in
	VGA	1 x VGA connector
	DVI-D	1
	PS/2	1 x Keyboard / mouse
Power	AC Input Voltage	250W, 90VAC~264VAC, 50/60 Hz
	DC power module	24V
Environmental	Temperature/Humidity	0°C~55°C / 95% (non-condensing)
	Certifications	CE, FCC
	Protection Class	Front panel IP65 compliant
	Vibration Resistance	2 Grms @ 5 ~ 500 Hz with CF/SSD, 0.5 Grms @ 5 ~ 500 Hz with HDD
	Shock Resistance	50 G @ wall mount half sine 11ms with CF/SSD 20 G @ wall mount half sine 11ms with HDD

Dimensions

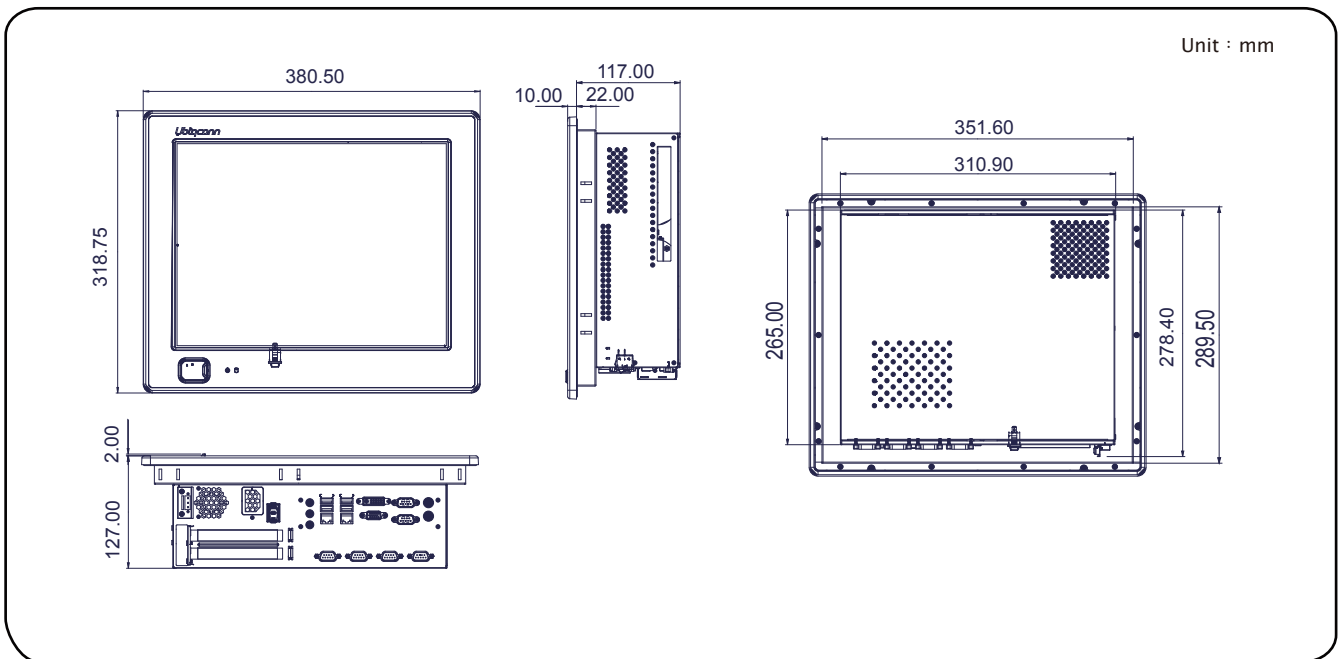

Front Accessible USB Port



I/O Diagram

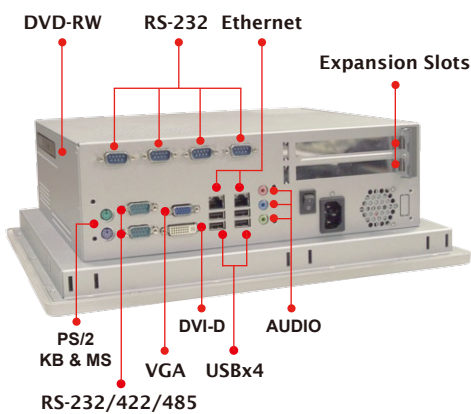

CPU Compatibility

CPU Family	Speed	TDP
Intel i7-27100E	2.1 GHz	45 W
Intel i5-2510E	2.5 GHz	35 W
Intel i3-2330E	2.2 GHz	35 W
Intel Celeron B810	1.6 GHz	35 W

Ordering Information

Part No.	Description
APP-M150-i3	15" Panel PC w/ Intel Core i3Celeron CPU
APP-M150-i5	15" Panel PC w/ Intel Core i5Celeron CPU
APP-M150-i7	15" Panel PC w/ Intel Core i7Celeron CPU

Accessories

Item	Description
Panel Mount Kit	Panel mount kits for APP-M series
Display Cable	VGA/DVI cable for second display

Options

Item	Description
16:9	15.6-inch display 1366 x 768, multi-touch
Touch Panel	18.5-inch display 1366 x 768, multi-touch
	24-inch display 1920 x 1080, multi-touch