

TPC-1251SR TPC-1551SR

12.1" SVGA/15" XGA High
Brightness LCD Intel® Atom™
Touch Panel Computers

NEW



Features

- Intel® Atom™ processor (up to 1.33 GHz)
- 12.1" SVGA/15" XGA High Brightness LED backlight
- -20 ~ 60°C wide operating temperature range
- Compact design with die-cast Al alloy front bezel
- Fanless cooling system
- NEMA4/IP65 compliant front panel
- Supports Microsoft® Windows WES7/XP/XPe/CE
- Dual Gigabit Ethernet supported
- Isolation Protection for Serial ports
- Energy Star approved

Introduction

For sunlight readable applications, the TPC extends its Touch Panel Computer range with a high brightness and optical bonding solution. The LCD display provides a 1000 nits solution. Optical bonding enhances its readability by providing a reflection rate of under 0.2%. TPC-1251SR/1551SR making it perfect for outdoor applications.

Specifications

General

- **BIOS** Award® 4 MB
- **Certifications** BSMI, CCC, CE, FCC Class A, UL
- **Cooling System** Fanless design
- **Dimensions (W x H x D)** 1251SR: 311 x 237 x 54 mm (12.24" x 9.33" x 2.12")
1551SR: 383 x 307 x 58.1 mm (15.08" x 12.09" x 2.29")
- **Enclosure** 1251H/1551H Front bezel: Die-cast Aluminum Alloy
Back housing: SECC
- **Mounting** Desktop, Wall or Panel Mount
- **OS Support** Windows XP/WES7/XPe/CE/Linux
- **Power Consumption** 35 W/40 W (typical)
- **Power Input** 18 ~ 32 V_{DC}
- **Watchdog Timer** 1 ~ 255 sec (system)
- **Weight (Net)** 2.5 kg (5.51 lb)/3 kg (5.51 lb)

System Hardware

- **CPU** Intel® Atom™ 1.33 GHz with 512KB cache
- **Chipset** eMenlow XL + Poulsbo
- **Memory** 1GB SO-DIMM DDR2 667 SDRAM
LAN 10/100/1000Base-T x 2
- **Storage** CompactFlash® slot x 1
- **I/O** RS-232 x 1 (with isolation)
RS-422/485 x 1 (with isolation)
USB 2.0 x 2 (Host)

LCD Display

- **Display Type** SVGA/XGA TFT LED LCD
- **Display Size** 12.1"/15"
- **Max. Resolution** 800 x 600/1024 x 768
- **Max. Colors** 262 K
- **Luminance cd/m²** 1000
- **Viewing Angle (H/V°)** 110/160, 120/140
- **Backlight Life** 50,000 hrs
- **Contrast Ratio** 600:1/1100:1

Touchscreen

- **Lifespan** 10 million touches at single point
- **Light Transmission** Above 75%
- **Resolution** Linearity
- **Type** 5-wire, analog resistive

Environment

- **Humidity** 10 ~ 95% RH @ 40°C, non-condensing
- **Ingress Protection** Front panel: NEMA4, IP65
- **Operating Temperature** -20 ~ 60°C (-4 ~ 140°F)
- **Storage Temperature** -30 ~ 80°C (-22 ~ 176°F)
- **Vibration Protection** 2 Grms (5 ~ 500 Hz)
(Operating, random vibration)

Dimensions

Unit: [mm]

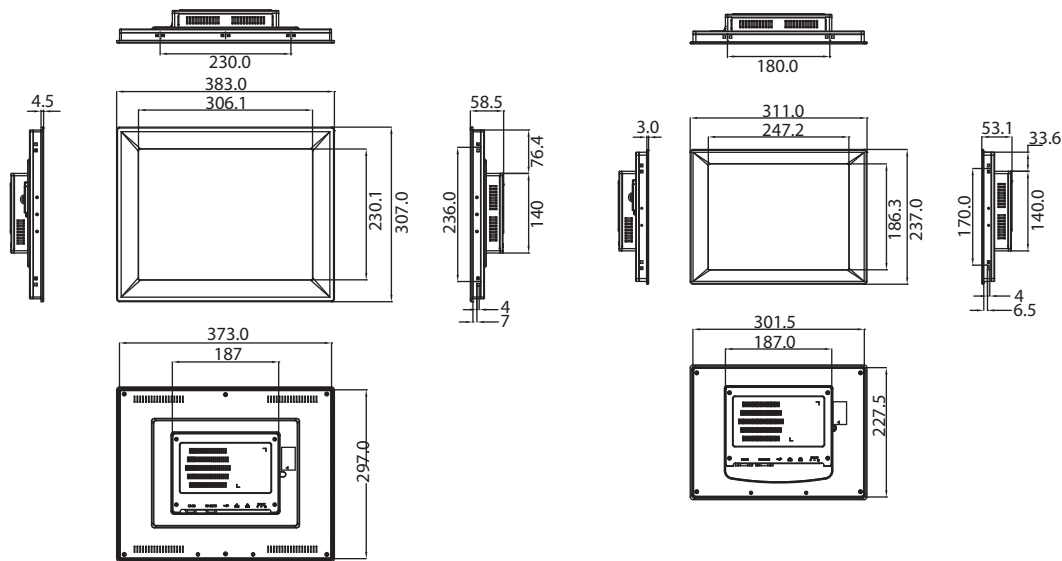

Panel Cut-out Dimensions: TPC-1251SR: 302.5 x 228.5 mm (11.9" x 9")
TPC-1551SR: 374.5 x 298.5 mm (14.7" x 11.7")

Ordering Information

- **TPC-1251SR-Z2AE** 12.1" Sunlight Readable Touch Panel PC, Atom™ 1.33GHz, 1GB
- **TPC-1551SR-Z2AE** 15" Sunlight Readable Touch Panel PC, Atom™ 1.33GHz, 1GB

Accessories

- **TPC-1570H-SMKE** TPC-1551SR Desktop Stand
- **TPC-1250H-SMKE** TPC-1251SR Desktop Stand
- **TPC-1570H-WMKE** TPC-1551SR Wallmount Kit
- **TPC-1250H-WMKE** TPC-1251SR Wallmount Kit
- **TPC-651H-EHKE** TPC-651H/1251H/1551H Extension HDD Kit
- **PWR-247-AE** 24 V 50 W AC-DC Power Adapter
- **1702002600** Power Cord 3P UL/CSA(USA) 125V 10A 1.83M

* Stand and Wall mount kits not compatible with HDD extension kit.

Rear View

TPC-1251SR/1551SR

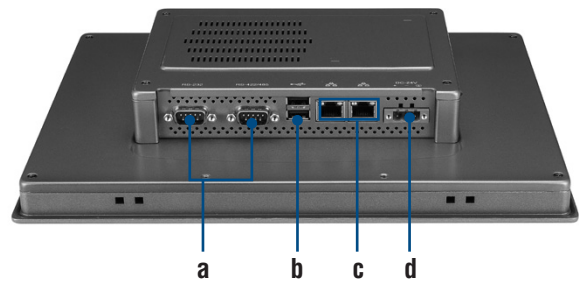

- a. COM (RS-232, RS-422/485)
- b. USB 2.0
- c. LAN (10/100/1000)
- d. Power Receptor