

1  
Industrial  
Computing  
Solutions

2  
Embedded  
Computing  
Solutions

3  
Industrial Data  
Collector  
and Controller

4  
Video  
Capture  
Solutions

5  
I/O  
Communication  
Solutions

6  
Panel  
Solutions

7  
ORing  
Network  
Communication

8  
Power Supply  
Peripherals

**NEW**  
**WStrider-200A**  
**IP67 Extend-Temperature  
Fanless Embedded Controller**

- ◆ Ultra low voltage Intel® Atom™ Z510PT solution
- ◆ IP67 compliant rugged design
- ◆ Fanless operation under -30°C ~70°C extreme temperature
- ◆ Built-in 802.11b/g/n high speed wireless communication
- ◆ 9~28VDC power input
- ◆ Two channels analog video input
- ◆ IEI One Key Recovery solution allows you to create rapid OS backup and recovery



One Key Recovery  
IEI dynamic

Fanless

Wireless  
802.11 b/g/n

IP 67

+70°C  
-30°C

WStrider-200A is a rugged embedded controller designed to operate in harsh usage environments and conditions. Its Aluminum die-casting enclosure and M12 watertight connector not only provides IP67 grade protection against dust and water, it also can withstand high impact by vandal usage. Empowered by Intel® Atom™ Z510PT with US15WPT industrial grade processor and chipset, WStrider-200A is able to operate under extreme temperature from -30°C to 70 °C. The built-in 802.11b/g/n module with IP67 compliant external antenna provides reliable high speed wireless communication. Furthermore WStrider-200A is capable of taking video input or image from analog camera by its built-in Techwell TW6805, providing upto two channels video capturing. For severe environment with unstable power source, WStrider-200A can take power input from 9VDC to 28VDC.



### Rugged IP67 Protection

The IP Code (International Protection Rating) is defined in international standard IEC 60529 and it classifies the degrees of protection provided against the intrusion of solid objects, dust, accidental contact, and water in electrical enclosures. WStrider-200A is a IP67 compliant controller and this dust-tight, water ingress resistant design has been verified severely throughout the design process in IEI's in-house UL50 certified waterproof laboratory. Air leak examination will also be applied during production to ensure every WStrider-200A is ready to operate reliably in harsh environment.

#### Air Leak Examination



#### Immersion test



#### [ IP67 ] Dust-tight

Level	Effective Against
6	No ingress of dust; complete protection against contact

#### [ IP67 ] 30 minutes immersion under one meter water

Level	Effective Against
7	Ingress of water in harmful quantity shall not be possible when the enclosure is immersed in water under defined conditions of pressure and time (up to 1m of submersion)

### Analog Video Input



## Wide Range DC Input

For severe environment with unstable power source, WStrider-200A can take power input from 9VDC to 28VDC. WStrider-200A uses 5-pin M12 connector as power input interface, which has different pin numbers to avoid power mistakenly connected to other IO for safety concern. You may apply DC power source directly to WStrider-200A via M12 5pin to terminal block cable in packing, or with optional IP67 60W power adaptor, apply AC source from the field.

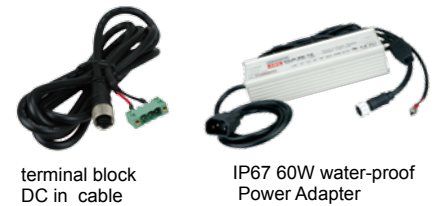

## IO Interface & Cabling

WStrider-200A uses IP67 compliant M12 and BNC connectors with watertight cap in pair for each connector. With watertight-to-PC interface cables, WStrider-200A can be easily connected to PC peripheral devices, operating just like common PC.

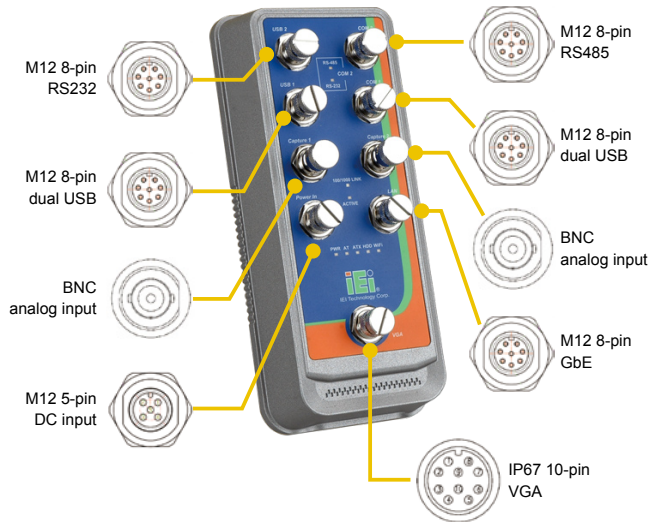

## Specifications

<b>Processor</b>	Intel® Atom™ 1.1GHz processor Z510PT with 400MHz FSB
<b>Chipset</b>	Intel® US15WPT
<b>System Memory</b>	1GB DDR2 SDRAM onboard
<b>Ethernet</b>	Intel® 82541PI GbE with M12 8pin connector
<b>Wireless</b>	Built in 802.11b/g/n for wireless model
<b>Display</b>	VGA signal with 10pin IP67 connector
<b>USB</b>	4 x USB 2.0, by two M12 8pin connector
<b>Serial Port</b>	1 x RS-232, with M12 8pin connector 1 x RS-422/485, with M12 8pin connector
<b>Capture</b>	2 x ch. By Techwell TW6805, with BNC connector
<b>Storage</b>	1 x CompactFlash Type II slot, 4GB CF pre-installed with XPE image
<b>Power Input</b>	9~28VDC in, with M12 5pin connector
<b>Power Consumption</b>	16W
<b>Chassis Construction</b>	Aluminum Alloy
<b>Operating Temperature</b>	-30°C ~ 70°C with air flow*
<b>Operating shock</b>	Half-sine wave shock 3G; 11ms; 3 shocks per axis
<b>Operating Vibration</b>	MIL-STD-810F 514.5C-2
<b>Weight (Net/Gross)</b>	1.3kg / 2.9kg
<b>Dimensions (DxWxH)</b>	99mm(W) x 61.7mm(D) x 230 mm (H)
<b>Mounting</b>	wall mount
<b>EMC/Safety</b>	CE, FCC class A, CCC

\* Ambient air speed pre IEC-68-2-2 standard

## Dimensions (unit: mm)

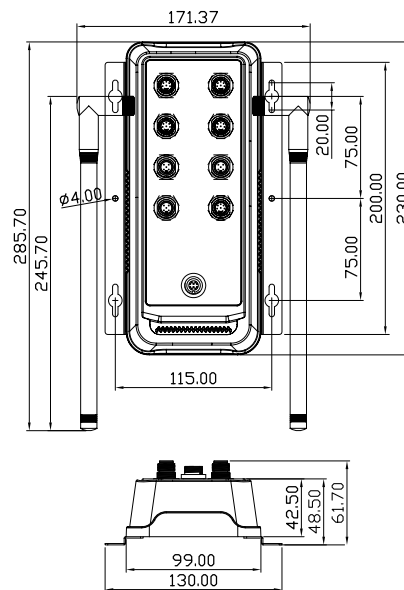

## Packing List

1 x QIG	1 x M12 10 pin VGA cable
1 x Driver CD	1 x M12 USB cable
1 x M12 5pin DC input cable	2 x wall mount bracket
1 x Screw set	2 x IP67 wireless antenna* (*for wireless model only)

## Ordering Information

Part No.	Description
<b>WSTRIDER-200A-R10/4G-XPE</b>	IP 67 extend temperature fanless embedded system, US15WPT with Intel® Atom™ 1.1GHz Z510PT processor, 1GB DDR2 memory onboard, with 4GB CF card, built in Windows® XP embedded OS, w/o power adaptor, RoHS
<b>WSTRIDER-200AW-R10/4G-XPE</b>	IP 67 extend temperature fanless embedded system, US15WPT with Intel® Atom™ 1.1GHz Z510PT processor, 1GB DDR2 memory onboard, 802.11b/g/n wireless, w/ 4GB CF card, built in Windows® XP embedded OS, w/o power adaptor, RoHS

\* For other CompactFlash capacity, please contact with IEI for customization.