

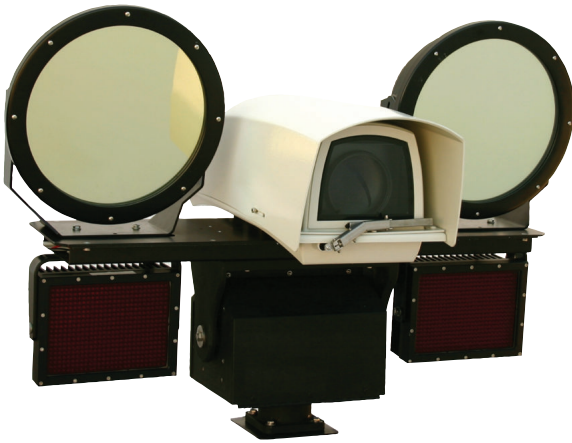

GVS1000 Long Range Imaging system



The GVS1000 is a system designed for long range, day/night, pan-tilt-zoom surveillance. The system delivers 1 km of recognition-level performance and 1200 m (3900 ft) of classification-level performance in total darkness. The GVS1000 provides long range 24/7 imaging for critical applications such as port and maritime monitoring, transportation and airport surveillance, and border and extended perimeter security.

To effectively perform to such capabilities, the GVS1000 is equipped with an IR-corrected, long range lens capable of 60x optical zoom. With a focal length of 12.5-750 mm or 25-1500 mm (with doubler function engaged), the lens works together with the high performance Dinion XF sensor to produce ultra-high quality images at far distances in day and night conditions.

System capability is greatly enhanced using active IR illumination. Two sets of illuminators are provided; one for long range and one for medium-to-short range night imaging. There are no safety concerns, as is the case with laser-based units. IR illumination can be controlled manually or put into automatic mode for auto on/off function via a photocell.

For control, the GVS1000 is compatible with Pelco P/D protocols input via RS422/RS485.

- ▶ **Integrated solution for long range day/night PTZ night vision**
- ▶ **60x IR-corrected motor zoom lens with focal length of 12.5-750 mm extending to 25-1500 mm with doubler function**
- ▶ **High performance Dinion XF CCD imaging core**
- ▶ **Dual ZX700 IR illuminators provide night vision performance to 1200 m (3900 ft) for Classification-level performance**
- ▶ **BDS208DS IR Illuminators for medium range night vision**
- ▶ **Weatherproof with cable-managed design**

Functions

Optics and IR

- IR-corrected 60x optical zoom for night vision beyond 1.2 km
- Best-in-class Dinion XF imaging performance
- Long range ZX700 IR illumination
- Medium/short range IR provided by dual BDS208DS with Black Diamond technology

PT Motor

- Variable speed and highly precise motor drive in pan and tilt
- Preset and tour functionality with hard and soft limits

System / Installation and Maintenance

- Designed to IP66 weather conditions
- Self-testing diagnostics function
- Indicator LEDs and voltage touch points for all maintenance requirements
- Hardened connectors and cables for long life
- External power indicator LED

Night-time performance range (under optimal conditions)

Level	Distance	Description
Classification	1,200 m (3,900 ft)	Performance level at which an object is determined to be human as opposed to an animal or other object.
Recognition	1000 m (3,300 ft)	Performance level at which a human-sized object is determined to be a threat or non-threat based on the type of clothing worn, equipment carried, etc. (friend or foe).
Identification	500 m (1,650 ft)	Performance level at which a human target can be identified as a specific individual.

Installation/Configuration Notes

Dimensions

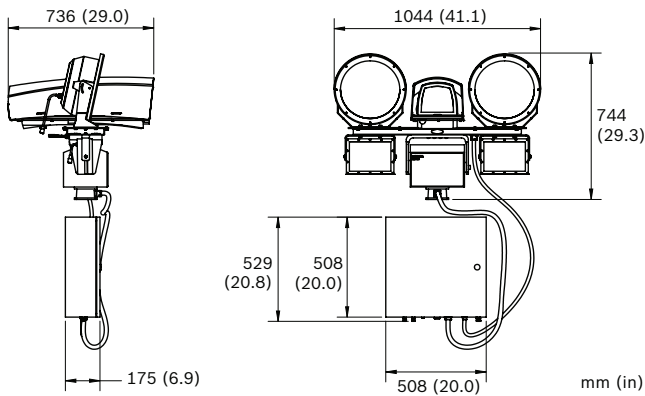

Motor base mounting template

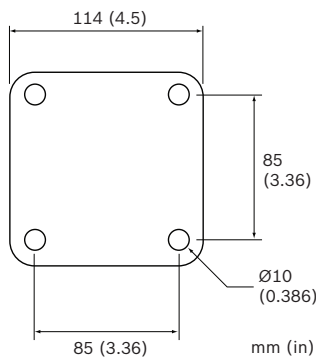

Technical Specifications

Long-Range Illumination

IR Illuminator	ZX700 IR
Wavelength	730 nm
Beam Pattern	2.5° spot beam with circular pattern
Bulb Life	Average 2,000 hours

Medium-Range Illumination

IR Illuminator	BDS208DS
Wavelength	850 nm
Beam Pattern	20° horizontal coverage, Black Diamond technology
LED Array	560 LED Array each (2x units used)

Optics

Camera Type	Dinion XF Day/Night Camera
TV System	NTSC or PAL
Resolution	540 TVL
Effective Pixels	NTSC: 768 (H) x 492 (V) PAL: 752 (H) x 582 (V)
S/N Ratio	Greater than 50dB
Gain Control	AGC
Lens Type	IR-Corrected 60x Motor Zoom Lens
Focal Length	12.5 mm to 750 mm 25 mm to 1500 mm with doubler
Magnification	60x optical
Zoom Operation	Motor drive (remote manual control)
Focus Operation	Motor drive (remote manual control)
Iris Operation	Automatic (remote manual control option)
Angle of View - Wide	28.4° horizontal x 21.4° vertical
Angle of View - Telephoto	0.29° horizontal x 0.22° vertical at 750 mm 0.15° horizontal x 0.11° vertical at 1500 mm
Focusing Range	5 m in front of lens to infinity
Wiper	Manual on/off control

Pan/Tilt Motor

Pan Range	± 215°
Tilt Range	± 90°
Pan Speed	0.3° to 8° per second
Tilt Speed	0.1° to 4.5° per second
Repeatability	0.25°
Motor Type	Permanent magnet
Drive Train	Steel gear and worm, ball and tapered roller bearing
Limit Switches	Adjustable hard limits, electronically adjustable soft limits
Backlash	Adjustable

Mechanical

Construction	All-weather aluminum construction with stainless steel fastenings
Finish	Baked enamel finish, black standard
Bracket	Cable management included
Dimensions (motor assembly)	1044 x 736 x 744 mm (L x W x H) 41.1 x 29 x 29.3 in (L x W x H)
Dimensions (PSU)	508 x 175 x 529 mm (L x W x H) 20 x 6.9 x 20.8 in (L x W x H)

Weight (excluding PSU)	50 kg (110 lb)
------------------------	----------------

IR Power Cable	7.5 m (25 ft)
----------------	---------------

PSU Composite Cable	6 m (20 ft)
---------------------	-------------

System Mount	4-inch PCD
--------------	------------

Environmental

Operation Temperature Range	-20 °C to +50 °C (-4 °F to 122 °F)
-----------------------------	------------------------------------

Environment	Designed to IP66
-------------	------------------

System Control

Protocol	Pelco P / D (RS422 / RS485)
----------	-----------------------------

Presets	32 pan / tilt / zoom presets
---------	------------------------------

Tours	3 pan / tilt / zoom tours with 63 presets per tour
-------	--

Electrical

Input Voltage	120 VAC or 230 VAC, 50/60 Hz
---------------	------------------------------

Power Requirements	800 W with full IR
--------------------	--------------------

Ordering Information

GVS1000-11-P Long Range Imaging System	GVS1000-11-P
---	---------------------

Long range PTZ imaging platform, day/night, 60x optical zoom, 12.5 to 750 mm / 25 to 1500 mm with doubler, 730 nm long range IR, PAL, Pelco P/D supported, 120 to 230 VAC PSU included.

GVS1000-11-N Long Range Imaging System	GVS1000-11-N
---	---------------------

Long range PTZ imaging platform, day/night, 60x optical zoom, 12.5 to 750 mm / 25 to 1500 mm with doubler, 730 nm long range IR, NTSC, Pelco P/D supported, 120 to 230 VAC PSU included.

Americas:
Bosch Security Systems, Inc.
130 Perinton Parkway
Fairport, New York, 14450, USA
Phone: +1 800 289 0096
Fax: +1 585 223 9180
security.sales@us.bosch.com
www.boschsecurity.us

Europe, Middle East, Africa:
Bosch Security Systems B.V.
P.O. Box 80002
5600 JB Eindhoven, The Netherlands
Phone: + 31 40 2577 284
Fax: +31 40 2577 330
emea.securitysystems@bosch.com
www.boschsecurity.com

Asia-Pacific:
Robert Bosch (SEA) Pte Ltd, Security Systems
11 Bishan Street 21
Singapore 573943
Phone: +65 6258 5511
Fax: +65 6319 3499
apr.securitysystems@bosch.com
www.boschsecurity.com

Represented by